

UPII Spring 2008 Course Guide

Part II: Magnetism and Optics

Dr. John and Gay Stewart

December 18, 2007

Contents

1	Electric Charge	2
1.1	Introduction to Electric Charge	2
1.2	Conservation of Charge	3
1.3	Quantization of Charge	4
1.3.1	Microscopic Origin of Charge	4
1.3.2	Quantization of Charge	5
1.3.3	Determining the Sign of a Charged Object	5
1.4	Charge in a Macroscopic Object	6
1.4.1	The Structure of Matter	6
1.5	What is a Macroscopic Net Charge?	8
1.6	Continuous Charge Distributions	8
1.6.1	What is a Charge Density?	8
1.6.2	Geometry	9
1.6.3	Computing Total Charge from a Density	9
2	Electric Force I	10
2.1	Basics of Electric Force	10
2.1.1	Qualitative Exploration of Electric Force	10
2.1.2	Properties of the Electric Force	12
2.2	Effect of Electric Force on Materials	13
2.2.1	Effect of Electric Force on Materials	14
2.2.2	Effect of Electric Force on a Charged Conductor	15
2.2.3	Charge Sharing	15
2.2.4	Charge Separation on a Conductor	16
2.2.5	Polarization of an Insulator	17
2.2.6	A Charged Object Attracts an Uncharged Object	18
2.2.7	Charging by Charge Separation	18
2.3	Capacity and Grounding	19
2.3.1	General Discussion of Capacity	19
2.3.2	Grounding	20
2.4	Shielding	21
2.4.1	Shielding Effect of a Conductor	21
2.5	Charging by Induction	23
2.5.1	Charging by Induction	23
2.6	Obtaining a Net Charge	24
2.7	Summary	25
2.7.1	Summary of the Basic Principles of Electrostatics	25
2.7.2	Placing the Charge You Want on a Conducting Sphere	25

3	Electrostatic Devices	28
3.1	Electrophorus	28
3.2	Leaf Electroscope	30
3.2.1	Building and Using a Leaf Electroscope	30
3.2.2	Demonstrating Charge Separation with a Leaf Electroscope	31
3.2.3	Charging a Leaf Electroscope by Induction	32
3.2.4	Demonstration of Capacity Using a Leaf Electroscope	33
3.2.5	Demonstrating Positive and Negative Charge with a Leaf Electroscope	34
4	Electric Force II	38
4.1	The Strength of the Electric Force	38
4.2	Review of Basic Vector Concepts	39
4.2.1	Vector Basics	39
4.2.2	Manipulating Vectors, Unit Vectors, and Magnitudes	40
4.2.3	Position and Displacement Vectors	41
4.3	Coulomb's Law	42
4.3.1	Qualitative Features of Coulomb's Law	45
5	Electric Field	48
5.1	Definition of Electric Field	48
5.2	Coulomb's Law for Electric Field	49
5.2.1	Coulomb's Law for the Electric Field	49
5.2.2	Fields of More than One Point Charge	51
5.3	Arrow Diagrams	52
5.3.1	Representing Electric Fields: Arrow Diagrams	52
5.3.2	Field and Force	53
5.4	Electric Fields of Lines and Planes	55
5.5	General Vector Fields	57
5.6	Electric Field of Many Objects	60
6	Mechanics	63
6.1	Mechanics Problems Involving the Electric Force	63
6.1.1	Review of Mechanics	63
6.1.2	Mechanics of Systems Involving Tension Forces	64
6.2	Mechanics in an Electric Field	64
7	Electric Field Maps	68
7.1	Gauss' Law, Field Lines, and Field Maps	68
7.1.1	Introduction to Gauss' Law	68
7.1.2	Reading Electric Field Maps	71
7.2	Drawing Electric Field Maps	73
7.2.1	Finding the Near and Far Fields of a System of Charge	73
7.2.2	Drawing Electric Field Maps	73
7.3	Drawing Arbitrary Continuous Fields	77
7.4	Combining Arrow Diagrams and Field Maps	78
8	Electric Dipoles	81
8.1	Behavior of Electric Dipoles	81
8.2	Drawing Dipole Fields	84
8.3	Qualitative Dipole Behavior	87
8.4	Dipole Mechanics	89
8.4.1	Potential Energy of a Dipole in an Electric Field	89
8.4.2	Torque on an Electric Dipole	89
8.4.3	Force on an Electric Dipole in a Non-Uniform Field	90

9	Continuous Charges	93
9.1	Thinking About Continuous Systems of Charge	93
9.2	One Dimensional Problems	94
10	Symmetry	98
10.1	High Symmetry Systems	98
10.2	The Shape of a High Symmetry Field	99
10.3	Drawing Spherical and Cylindrical Systems	100
10.4	Drawing Planar Systems	102
11	Gauss' Law	103
11.1	Electric Flux	103
11.1.1	Working with Dot Products	103
11.1.2	Definition of Electric Flux	104
11.1.3	Qualitative Meaning of Flux	105
11.1.4	What is a Surface Integral?	106
11.2	Gauss' Law	107
11.3	Specializing Gauss' Law to the Symmetry	108
11.3.1	Specializing Gauss' Law for Spherical Symmetry	108
11.3.2	Specializing Gauss' Law to Cylindrical Systems	109
11.3.3	Specializing Gauss' Law for Planar Symmetry	110
11.3.4	Another Way to Look At It	111
11.4	Application of Gauss' Law	111
11.4.1	Applying Gauss' Law to Spherically Symmetric Distributions of Charge	111
11.4.2	Applying Gauss' Law to Planar Symmetry	113
11.4.3	Applying Gauss' Law to Cylindrical Systems	115
12	Final Topics Test 1	117
12.1	Long Range Fields	117
12.2	Gauss' Law Inside and Outside All Charge	118
13	Conductors and Dielectrics	119
13.1	Response of Materials	119
13.1.1	The Electric Response of Conductors	119
13.1.2	Basic Properties of Dielectrics	121
13.1.3	Dielectric Breakdown	122
13.2	Field Maps of Point Charges	122
13.3	Charge Density at a Surface	125
13.4	Planar Conductors and Dielectrics	127
13.4.1	Response of a Plane Conductor	127
13.4.2	Response of a Plane Dielectric	127
13.5	Superposition	129
14	High Symmetry Systems II	134
14.1	Field Maps	134
14.1.1	Adding a Conductor to a Symmetric Field Map	134
14.1.2	Adding a Dielectric to a Symmetric Field Map	135
14.2	Electric Field	136
15	Non-Uniform Charge Densities	146
15.1	Non-Uniform Charge Densities	146

16 Work and Energy	148
16.1 Force and Work	148
16.2 Total Energy	149
16.3 Kinetic and Potential Energy	150
16.3.1 Kinetic and Potential Energy	150
16.3.2 Conservation of Energy	150
16.4 Potential Energy and Force	152
16.5 Two Dimensional Potential Energy Plots	153
17 Electric Potential	155
17.1 Introduction to Electric Potential	155
17.1.1 Potential and Potential Difference	155
17.1.2 Electric Potentials of a Single Variable	158
17.1.3 Independence of Path	158
17.1.4 Batteries	159
17.2 Qualitative Features of Electric Potential	159
17.2.1 Qualitative Features of Electric Potential	159
17.2.2 Drawing Equipotential Surfaces	161
17.3 Computing Potential from Field	167
17.3.1 Computing Potential Difference Directly from Definition	167
17.3.2 Calculating Potential Difference from Potential	170
17.3.3 Electric Potential Difference in Uniform Field	171
17.4 Calculating Potential Directly from Charge	172
17.4.1 Electric Potential of a Point Charge	172
17.4.2 Electric Potential of a Continuous System of Charge	176
17.5 Potential in Highly Symmetric Systems	177
17.6 Electric Potential Energy and Motion	179
18 Electrostatic Energy	183
18.1 Electrostatic Energy	183
18.2 Electrostatic Energy Density	185
19 Capacitance	187
19.1 Definition of Capacitance	187
19.1.1 Definition of Capacitance	187
19.1.2 Capacitance and Energy	188
19.1.3 Effect of Dielectrics on Capacitance	190
19.2 Capacitance from Electrostatics	191
19.2.1 Computing the Capacitance of a Two Conductor System	191
19.2.2 Calculating the Capacitance of One Conductor and Ground	199
20 Current and Resistance	201
20.1 Current	201
20.1.1 Current	201
20.1.2 Circuit Diagrams and Measurement Tools	203
20.1.3 Potential Difference In Electric Circuits	204
20.1.4 Power Dissipated/Provided to Electric Circuits	205
20.2 Resistance and Resistivity	206
20.2.1 Resistance	206
20.2.2 Resistance of Materials	207
20.2.3 But that's all garbage	209

21 DC Circuits	211
21.1 Ohm's Law	211
21.1.1 Ohm's Law	211
21.1.2 Physical Batteries	213
21.2 Resistor Networks	213
21.2.1 Identifying Series and Parallel Combinations of Resistors	213
21.2.2 Reducing Resistor Networks	215
21.3 Kirchhoff's Laws	220
21.3.1 Kirchhoff's Laws	220
21.3.2 Navigating Multi-Loop Circuits	221
21.3.3 Analyzing Kirchhoff's Law Problems	222
22 Capacitive Circuits	231
22.1 Capacitor Networks	231
22.1.1 Combining Capacitors	231
22.1.2 Reducing Capacitive Circuits	233
23 RC Circuits	238
23.1 Reasoning About RC Circuits	238
23.1.1 General Behavior of RC Circuits	238
23.1.2 Short and Long Time Behavior of RC Circuits	238
23.2 RC Circuits	242
23.2.1 General Behavior of RC Circuits	242
23.2.2 Exponential Time Dependence	243
23.2.3 Discharging RC Circuits	246
23.2.4 Charging RC Circuit Behavior	249
23.3 Graphing RC Circuits	251
24 Final Topics Test 2	254
24.1 What Does a Capacitor Do?	254
24.2 Revisiting Shielding by Conductors	255
25 Biot-Savart Law	257
25.1 No Magnetic Charge	257
25.1.1 No Magnetic Charge	257
25.1.2 Maxwell's Equations Part I	258
25.2 Biot-Savart Law	258
25.2.1 Mathematical Preliminaries - The Cross Product	259
25.2.2 Introduction to Magnetostatics	261
25.2.3 Biot-Savart Law	262
25.2.4 Representing Magnetic Fields at Right Angles to the Page	264
25.3 Simple Current Distributions	265
25.3.1 Understanding the Difference Between Important Magnetic Fields	265
25.3.2 Magnetic Field of Infinite Wire	266
25.3.3 Field of a Finite Current Element	267
25.3.4 Magnetic Field of an Infinite Solenoid	270
25.4 Drawing the Magnetic Field	272
26 Computing Magnetic Fields	276
26.1 Adding Magnetic Fields	276
26.2 Arbitrary Currents	282
26.2.1 Finding Total Magnetic Field for Currents Lying in a Plane	282
26.2.2 Magnetic Field of Special Current Distributions	290

27 Ampere's Law	292
27.1 Ampere's Law	292
27.1.1 Ampere's Law	292
27.1.2 How to Tackle Ampere's Law	292
27.1.3 Using Ampere's Law to Find Current in a Field Map	294
27.2 Cylindrical Systems	295
27.2.1 Ampere's Law in Cylindrical Systems	295
27.3 Planar Systems	299
27.4 Solenoids	301
28 Magnetic Force	304
28.1 Magnetic Force	304
28.1.1 The Lorentz Force	304
28.1.2 Consequences of the Form of the Lorentz Force	307
28.1.3 Newton's Third Law and the Magnetic Force	308
28.2 Circular Motion in a Uniform Magnetic Field	309
28.3 Forces on Currents and Wires	311
29 Magnetic Dipoles	314
29.1 Drawing and Reading Magnetic Field Maps	314
29.1.1 Drawing the Magnetic Field of a Magnetic Dipole	314
29.1.2 Quantitative Form of Magnetic Dipole Field	317
29.2 Behavior of Dipoles in Magnetic Fields	317
29.2.1 Rotation of Magnetic Moments in a Magnetic Field	317
29.2.2 Torque and Potential Energy of a Magnetic Dipole	320
29.2.3 Motion of Dipole in Non-Uniform Field	323
30 Magnetic Materials	327
30.1 Introduction to Magnetic Materials	327
30.1.1 Magnetic Response of Materials	327
30.1.2 Paramagnetism and Diamagnetism	328
30.2 Ferromagnetism	329
30.2.1 Ferromagnetism	329
30.2.2 Commercial Magnetic Materials	330
31 Faraday's Law	332
31.1 Electromotive Force	332
31.1.1 Electromotive Force	332
31.1.2 Drawing the Forces on the Charges in a Moving Wire	333
31.1.3 Calculating Motional EMF	334
31.2 Magnetic Flux	336
31.3 Faraday's Law	338
31.3.1 Faraday's and Lenz' Law	338
31.3.2 Drawing the Electric Fields Resulting From Changing Magnetic Fields	340
31.3.3 Eddy Currents	340
31.3.4 Quantitative Statement of Faraday's Law	341
31.3.5 Calculations using Faraday's Law	342
31.4 Generators	345
32 Inductance	349
32.1 Inductance	349
32.2 Inductors	351
32.3 Mutual Inductance and Transformers	354
33 Magnetic Energy	358
33.1 Magnetic Energy	358

34 RL Circuits	360
34.1 Limiting Behavior of RL Circuits	360
34.2 RL Circuits	363
35 Final Topics Test 3	368
35.1 Devices Utilizing the Lorentz Force	368
35.1.1 Speaker I	368
35.1.2 Speaker II (Commercial)	368
35.1.3 Motors	369
35.2 Devices Utilizing Faraday's Law	370
35.2.1 Microphones	370
35.2.2 Generators	371
36 Displacement Current	372
36.1 Displacement Current	372
36.1.1 Why Does Ampere's Law Need Fixing?	372
36.1.2 Ampere's Law for Electrodynamics	373
36.2 Visualizing the Induced Electric Field	376
36.3 Maxwell's Equations	376
37 Electromagnetic Waves	378
37.1 A Solution to Maxwell's Equation	378
37.1.1 The Speed of Light	378
37.1.2 For Cal III People Only	382
37.2 Electromagnetic Waves	383
37.2.1 Let There Be Light	383
37.2.2 Summary of the Results of the Wave Solution to Maxwell's Equations	383
37.2.3 Features of Moving Waves	385
37.2.4 The Spectrum	387
37.3 Mechanical Properties	388
37.4 Antennae for EM Waves	390
37.5 Polarization	392
37.5.1 Polarization	392
37.5.2 Polarization Mechanisms	393
37.5.3 Circular Polarization	394
38 Light	395
38.1 Light and Matter	395
38.1.1 Index of Refraction	395
38.1.2 Wave Properties of Light in Matter	396
38.2 Reflection at a Plane Interface	397
38.2.1 Light Rays	397
38.2.2 Reflection at Plane Interfaces	398
38.3 Snell's Law - Refraction at Plane Interfaces	398
38.3.1 Refraction at Planes Interfaces - Snell's Law	398
38.3.2 Critical Angle	399
38.4 Transmission and Reflection	402
38.4.1 Intensity of Transmission and Reflection	402
38.4.2 Polarization by Reflection - Brewster's Law	404
39 Geometric Optics	407
39.1 Image Formation	407
39.1.1 What is an Image?	407
39.1.2 Describing Images	409
39.1.3 Real and Virtual Images	410
39.2 Image Formation by Flat Surfaces	411

39.2.1	Image Formed by a Flat Mirror	411
39.2.2	Image Formed by Refraction at a Flat Surface	413
39.3	Thick Spherical Interfaces	414
39.3.1	Image Formation in a Curved Mirror	414
39.3.2	Image Formation by Refraction at a Curved Surface	417
39.3.3	Forming Images by Refraction	418
39.3.4	A Thin Lens	423
40	Thin Lenses and Mirrors	425
40.1	Image Formation Using Mirrors	425
40.1.1	Types of Mirrors	425
40.1.2	Focal Point and Focal Length of a Mirror	425
40.1.3	Landmarks of Spherical Mirrors	427
40.1.4	Ray Tracing for Spherical Mirrors	430
40.1.5	Mathematically Locating the Image for a Spherical Mirror System	431
40.2	Image Formation by Thin Lenses	434
40.2.1	Working with Thin Lenses	434
40.2.2	Focal Point for Convex and Concave Lenses	438
40.2.3	Ray Tracing for Thin Lenses	439
40.2.4	Computing and Describing the Image Location of a Thin Lens	440
41	Ray Diagram Reference	444
41.1	Ray Tracing for Concave Mirrors	444
41.2	Ray Tracing for Convex Mirrors	450
41.3	Ray Tracing for Convex Lenses	455
41.4	Ray Tracing for Concave Lenses	457
42	Optical Systems	460
42.1	Optical Systems	460
42.1.1	Optical Systems Containing More than One Element	460
42.1.2	Virtual Objects	462
42.2	The Eye	463
42.3	A Simple Magnifier	466
42.4	The Compound Microscope	469
42.5	The Telescope	471
43	Appendix	474
43.1	Units	474
43.2	Constants	475
43.3	Presenting your Work	475
44	Index	477

Chapter 1

Electric Charge

We are all familiar with the basic feature of matter called mass, which determines how strongly the gravitational force pulls on an object. A second fundamental feature of all matter is electric charge. This course deals with the effects of stationary and moving electric charges.

1.1 Introduction to Electric Charge

In this class, we deal with one thing and one thing only: the consequences of the existence of *electric charge*. Electric charge is a fundamental property of everything in the universe. For almost all processes it is the most important feature. Electric charge is like a label attached to everything in the universe. If you grind something up and try to sort out the pieces of “charge” you won’t be able to do it, but all the pieces you make *will* have an electric charge: either +, −, or 0.

Definition of Electric Charge: *Electric Charge, Q or q ,* is a fundamental feature of every object in the universe. Electric charge is like a label attached to everything in the universe. It has no real definition, because to define something we must express it in terms of other fundamental features. Electric charge just is, like mass just is. We will define electric charge by the effects.

Unit of Electric Charge: The unit of electric charge is the Coulomb, C . Since electric charge is a new fundamental idea, the Coulomb is a new fundamental unit and cannot be expressed in terms of the units from mechanics: kg, m, s. It is the only new unit we actually need for this class.

Electric charge could have behaved in any manner. It could have been an vector or a matrix. It might not have had any mathematical representation at all. That it behaves as a simple number (a scalar) is going to make the rest of the class a whole lot easier than it might have been.

Charge is Positive, Negative, or Zero: The electric charge of an object is either positive, negative, or zero.

You probably have heard about electric charge since you were a kid, so this may seem like a trivial point to make. However, electric charge could have been red and blue and added up to make a third kind of charge, purple, rather than + and − which can add up to zero, so this is a real feature of the universe.

Electric Charge is Additive: If positive charge is mixed (somehow) with negative charge, then charge cancels and you get a total charge that is the sum of the two charges.

One Coulomb is an enormous amount of charge, and we will rarely work with charges that big, unless we’re talking about lightning or computing the amount of charge that has the energy of a nuclear explosion when confined to some volume. Normally we will work with very small fractions of a Coulomb and use the following abbreviations:

Symbols for Small Quantities of Charge: We often give you charges in milli-Coulombs ($\text{mC} = 1 \times 10^{-3}\text{C}$), micro-Coulombs ($\mu\text{C} = 1 \times 10^{-6}\text{C}$), or nano-Coulombs ($\text{nC} = 1 \times 10^{-9}\text{C}$).

Abbreviation	Example	Value
milli	mC	$1 \times 10^{-3}\text{C}$
micro	μC	$1 \times 10^{-6}\text{C}$
nano	nC	$1 \times 10^{-9}\text{C}$
pico	pC	$1 \times 10^{-12}\text{C}$

Usually, if you calculate a charge much larger than $1\mu\text{C}$, you probably have done something wrong.

1.2 Conservation of Charge

Charge is the most important microscopic feature of any object. For the universe's continued existence as we know it, it is important that this feature is maintained. Fortunately, the total charge is conserved in ALL microscopic and therefore in all macroscopic processes.

Law of Conservation of Charge: In all physical processes, the *total* charge before the process, $\sum Q_{\text{initial}}$, is equal to the total charge after the process, $\sum Q_{\text{final}}$.

$$\sum Q_{\text{initial}} = \sum Q_{\text{final}}$$

This law does not mean that the number of protons and electrons in the universe remains the same. Nuclear processes change the number of protons, neutrons, and electrons. For example, your smoke detector turns a neutron (charge 0) into an electron (charge $-e$), a proton (charge $+e$), and an antineutrino (charge 0). So the number of charged particles changes but the total charge of the universe is the same, $0 = -e + e + 0 = 0$.

In lab, and in your own personal experience, charge sometimes *SEEMS* to disappear. In these cases, it has actually escaped into the atmosphere, the earth, or your body. We will call everywhere that charge escapes to the *environment*.

Exchange of Charge with the Environment: If we are moving charge from place to place or just letting a charged object sit around, some charge may be lost to the environment.

Later on, we will be able to use a battery or a charged rod to draw charge out of the environment. When analyzing a charge conservation process, missing charge or extra charge comes from the environment: the Earth, water vapor in the air, etc.

Example 1.1 Adding Two Containers of Charge

Problem: Two containers with net charge are connected so that opening a valve will mix the charge. One container has total charge $Q_1 = 7\text{C}$ and the other has total charge $Q_2 = -5\text{C}$. No charge escapes to the environment in the mixing process. What will the final charge of each container be once the valve is opened and the charge mixes? Assume the containers are identical.

Solution

Since no charge is lost to the environment and charge is conserved,

$$\sum Q_{\text{initial}} = Q_1 + Q_2 = 7\text{C} - 5\text{C} = 2\text{C} = \sum Q_{\text{final}}$$

As the containers are symmetric, the charge is equally shared between the two containers.

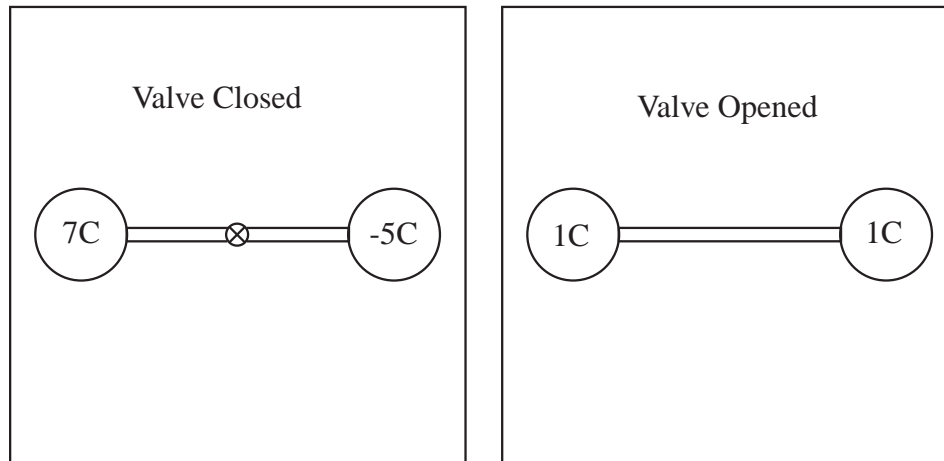

1.3 Quantization of Charge

In this class, we will almost exclusively deal with non-atomic processes where a lot of charge is involved. That charge comes in discrete pieces, usually electrons, but sometimes protons or ions. In this section, we work with charge in its natural chunks.

1.3.1 Microscopic Origin of Charge

The everyday things around us are made up of atoms. Atoms are composed of a nucleus made up of a number of protons and neutrons. Around the nucleus, a number of electrons orbit. If the number of electrons equals the number of protons then the atom is electrically neutral, that is it has zero net charge. If the number of electrons is different from the number of protons, the atom has a net charge and is called an *ion*.

Fundamental Unit or Quantum of Charge: Charge comes in discrete pieces that can be expressed in terms of the fundamental unit of charge $e = 1.602 \times 10^{-19}\text{C}$.

The constants e , m_p , and m_e have been measured to exceptional precision. For the most precise value of these constants visit the National Institute of Standards or NIST at <http://physics.nist.gov/PhysRefData/contents.html>.

Charge of Elementary Particles: The proton has a charge $+e = +1.602 \times 10^{-19}\text{C}$, the charge of an electron is $-e = -1.602 \times 10^{-19}\text{C}$, and the charge of the neutron is 0C .

Masses of Fundamental Particles: While we're at it, the two fundamental charged particles which make up most of the charged matter in the universe (with the uncharged neutron) have fixed masses. The mass of the electron is $m_e = 9.11 \times 10^{-31}\text{kg}$ and the mass of the proton is $m_p = 1.67 \times 10^{-27}\text{kg}$. Therefore if I tell you something is an electron, I don't have to give you the mass.

The proton and electron make up the vast majority of the charged mass in the universe. The proton, neutron, and electron make up the vast majority of normal mass in the universe. Note, most of the universe is dark energy or dark matter that we have no clue about. Over the course of the 20th century a diverse array of other charged particles were found. The electron has two cousins, the muon and the tau, that together are called leptons. Each have charge $-e$. Each lepton has a neutrino that has charge zero. The proton and neutron are made up of quarks that have charge $\pm\frac{1}{3}$ and $\pm\frac{2}{3}$. The quarks in the proton and neutron are given the names *up* and *down*. They have four siblings: charm, strange, top, and bottom. Quarks are an odd animal in that you cannot ever find a quark on its own; they are always found in twos and threes such that the total charge of any free particle composed of quarks is some integer multiple of e . The remaining particles are the particles that carry the forces: the photon, the gluon, and the graviton. Each has zero charge. The particles that carry the so called weak force have charges 0 , and $\pm e$. All the exotic particles are created only at high energy and are fairly short lived, so we don't have to worry about them when we analyze a toaster. For any material we will work with, the positive charge comes from protons and the negative charge from electrons.

1.3.2 Quantization of Charge

Since all the charged particles in the universe have charges that are some integer multiple of e , the charge of any object, even a macroscopic object with tons of atoms, is some integer multiple of e .

Law of Quantization of Charge: Charge comes in discrete chunks of size $\pm e$ ($e = 1.6 \times 10^{-19} \text{C}$). So a macroscopic bunch of charge Q can be divided into N magnitudes of the fundamental charge:

$$Q = \pm Ne.$$

where N is an integer.

It is possible to exchange ions that have excess positive charge—you do it in chemistry all of the time. In this class we will move charge with wires and sparks and can assume that the *net* charge being moved is electrons, and that the rest of the atomic components stay put. In all cases however, we will report the charge of an object as the number of additional (excess) electrons it has over the number required to be electrically neutral or the number fewer (deficient) electrons it has than is required for neutrality.

Excess and Deficient Electrons: Net Charge will be reported as an **Excess Of** or **Deficiency In** Electrons

Example 1.2 Computing the Number of Elementary Charges in a Macroscopic Charge

Problem: In this class we routinely deal with $1\mu\text{C}$ charges. How many excess or deficient electrons make a $1.0\mu\text{C}$ charge?

Solution

If the charge Q is made up of an integer number of charged particles whose charge is $\pm e$, then $Q = \pm Ne$ where N is the number of electrons, Q is the total charge, and $e = 1.602 \times 10^{-19} \text{C}$.

$$N = \left| \frac{Q}{e} \right| = \frac{1.0 \times 10^{-6} \text{C}}{1.602 \times 10^{-19} \text{C}} = 6.212$$

The law of quantization of charge requires that N is an integer, but that only affects the 12th significant figure in the number above. Electrons have a negative charge. An object is *deficient* in electrons if the object's charge is positive.

$$N = 6.2 \times 10^{12} \text{ deficient electrons}$$

1.3.3 Determining the Sign of a Charged Object

In lab, we work with many charged objects. How can the sign of the charge on the object be determined? It is relatively easy to determine when something is charged because it then exerts a force on other objects. Determining the sign of the charge is more difficult.

The Sign of the Electric Charge is Arbitrary: The universe does not have little + and – signs stamped on everything, so the choice of whether the charge on the proton is the positive charge or the charge on the electron is the positive charge was arbitrary.

Ben Franklin chose and most people feel his choice was bad. It would be far more convenient if the electron had been assigned the positive charge. Since the choice was arbitrary, we need a reference with known charge to determine the sign of the charge of an object.

Constructing a Positively Charged Reference Object: The clear plastic rod in lab developed a positive charge when rubbed with felt. A glass rod rubbed with silk also has a positive charge.

Constructing a Negative Reference Charged Object: A PVC rod rubbed with felt becomes negatively charged. The golf tube rubbed with the oven bag has a negative charge.

1.4 Charge in a Macroscopic Object

1.4.1 The Structure of Matter

The number of protons in the nucleus almost completely determines the chemistry of the atom. Atoms with the same number of protons are grouped within elements such as Carbon and Oxygen.

Definition of Element: An element, like Hydrogen or Helium, is all atoms with the same number of protons in their nucleus.

The number of neutrons in the nucleus can vary somewhat from atom to atom for different atoms of the same element. An atom with fixed number of protons and neutrons is called a *nuclide*. The collection of nuclides belonging to the same element are the *isotopes* of the element. A nuclide is characterized by the atomic number Z and the *mass number*, A . The mass number is the total number of protons and neutrons. For example, a nuclide of carbon, one of the isotopes of carbon, with 6 protons (like all carbon atoms) and 7 neutrons would have atomic number 6 and mass number $13 = 6 + 7$. This nuclide is represented by the symbol ${}^13_6\text{C}$. This nuclide is called Carbon-13 as opposed to its more common relative with 6 neutrons, ${}^{12}_6\text{C}$, Carbon-12.

Atomic Number: The atomic number, Z , of an atom is the number of protons in the atom. Since atoms are neutral it is also the number of electrons. The atomic number of Carbon is 6, so there are 6 protons and 6 electrons in an atom of carbon.

Mass Number: The mass number, A , is the total number of protons and neutrons in an atom.

Any macroscopic object contains an enormous number of atoms; a number that is too large to conveniently work with. Instead of working with the number of atoms, a arbitrary characteristic number of atoms in a macroscopic object is defined, the *mole*.

Definition of Mole: A mole is a number of objects. One mole is defined as the number of carbon atoms with mass number 12 (6 protons and 6 neutrons) required to make 12 grams of carbon.

Avogadro's Number: The number of atoms (or anything) in one mole is called Avogadro's Number, N_A , and equals

$$N_A = 6.022 \times 10^{23}$$

The different isotopes of an element occur naturally with different abundances. For example, there is a lot more Carbon-12 around than Carbon-13. The periodic table lists the average mass of one mole of an element. This mass is given the name the *atomic mass*.

Atomic Mass: The atomic mass of an element is the mass of one mole of the element in grams. So if a periodic table gives the mass of Helium as 4.0026 amu, then a mole has a mass 4.0026g.

The periodic table reports the chemical symbol, the atomic number, Z , and the atomic mass as

$$\begin{array}{c} Z \\ \text{Symbol} \\ \text{Mass} \end{array} \Rightarrow \begin{array}{c} 6 \\ \text{C} \\ 12.01 \end{array}$$

where the periodic table entry for carbon is given as an example. If you have already sold back your chemistry book, the web site www.webelements.com is an excellent source of chemical information.

Example 1.3 Computing the Number of Electrons in Aluminum

Problem: You are given 10kg of aluminum.

(a) How many electrons are in the aluminum?

Select One of the Following:

- (a) 5.8×10^{30} electrons
- (b) 2.9×10^{30} electrons
- (c) 2.9×10^{24} electrons
- (d-Answer) 2.9×10^{27} electrons
- (e) 5.8×10^{27} electrons

(b) What is the total charge of the electrons?

Select One of the Following:

- (a) $-4.6 \times 10^7 C$
- (b-Answer) $-4.6 \times 10^{10} C$
- (c) $-9.2 \times 10^9 C$
- (d) $4.6 \times 10^{10} C$
- (e) $-4.6 \times 10^{13} C$

Solution to Part(a)

(a) Compute Moles of Aluminum: The atomic mass of aluminum is 26.98154u where u is an atomic mass unit. By the definition of atomic weight, one mole of aluminum has a mass of 26.98154g. Therefore, our block of aluminum contains

$$N = \frac{10\text{kg}}{26.98154 \frac{\text{g}}{\text{mole}}}$$

$$N = 370 \text{ moles of aluminum atoms,}$$

where I have used $1000\text{g} = 1\text{kg}$.

(b) Compute the Number of Atoms: The number of atoms of aluminum is the number of moles multiplied by Avogadro's number

$$N = (370 \text{ moles}) \left(6.022 \times 10^{23} \frac{\text{atoms}}{\text{mole}} \right) = 2.23 \times 10^{26} \text{ atoms of Aluminum}$$

(c) Compute the Number of Electrons: Aluminum is number 13 in the periodic table, and therefore has 13 electrons per atom. The total number of electrons in the block of aluminum is then

$$N_e = N \cdot 13 = 2.9 \times 10^{27} \text{ electrons}$$

Solution to Part(b)

The total charge of the electrons is

$$Q = -eN_e = -(1.6 \times 10^{-19} C)(2.9 \times 10^{27} \text{ electrons})$$

$$Q = -4.6 \times 10^{10} C$$

From the above, a very very small percentage of the atomic charge is involved in even the largest macroscopic charge.

1.5 What is a Macroscopic Net Charge?

What is *net charge*? Charged particles are literally everywhere. If we take a rock, it contains on the order of Avogadro's number, N_A , ($N_A = 6.022 \times 10^{23}$) of atoms, all of which have one or more protons and electrons. If the protons and electrons in the rock could be separated, the protons or the electrons taken separately have an enormous charge as demonstrated above.

Total Charge of Avogadro's Number of Protons: A mole of protons has total charge

$$Q = N_A e = (6.022 \times 10^{23})(1.602 \times 10^{-19} \text{C}) \approx 1 \times 10^5 \text{C},$$

which is a VERY large net charge.

In this class, the net charges we will work with range up to a few micro Coulombs (μC), $1\mu\text{C} = 1 \times 10^{-6}\text{C}$. For this charge a very small fraction of the atoms in the charged objects have gained or lost an electron.

Fraction of Atoms Contributing to a Net Charge: The fraction of atoms out of Avogadro's number of atoms which must lose an electron to produce a charge of $1\mu\text{C}$ is

$$\frac{1 \times 10^{-6}\text{C}}{1 \times 10^5\text{C}} = 1 \times 10^{-11} \quad \text{fraction of atoms losing an electron.}$$

This does not mean that only a few electrons are involved in a net static charge. The smallest(non-atomic) charge we will deal with in class will be a few pico-Coulombs ($p\text{C}$), $1p\text{C} = 1 \times 10^{-12}\text{C}$. Because the charge of an electron or proton is so small, this $1p\text{C} = 1 \times 10^{-12}\text{C}$ charge still involves the loss of a huge number of electrons.

Number of Elementary Particles in Minimum Macroscopic Charge: If we take $1p\text{C} = 1 \times 10^{-12}\text{C}$ as the smallest charge we can detect in this class, the smallest number of lost electrons we can detect is

$$N = \frac{1 \times 10^{-12}\text{C}}{1.602 \times 10^{-19}\text{C}} \approx 10^7 \quad \text{deficient electrons,}$$

which is still a lot of particles to move around.

So a macroscopic net charge results from a gain or loss of an electron by a very small fraction of the atoms in a material, but still involves the gain or loss of a very large number of electrons.

1.6 Continuous Charge Distributions

A macroscopic charged object has a very large number of excess or deficient electrons. Therefore we can, to a very good approximation, work with charge densities instead of individual charges.

1.6.1 What is a Charge Density?

The objects which actually have charge, protons and electrons, have a very small charge $e = 1.6 \times 10^{-19}\text{C}$. Therefore any charge process which we can detect without very sensitive instruments involves a large number of fundamental particles. In lab, we established a charge of $-0.1\mu\text{C}$ by rubbing the golf tube. In the example above, it was computed that $1\mu\text{C}$ required the removal of 6.25×10^{12} electrons. The electrons are added all over the surface of the golf tube. The complete description of the electric properties of the golf tube involves giving the location of each and every electron. It is inconvenient and usually impossible to keep track of this number of objects. The number of objects is so large that we can, without introducing any significant error in calculations, describe the charge of golf tube by how much total charge occupies some area of the tube, that is by its surface charge density.

Three charge densities are important in describing extended charged objects, called *charge distributions*. We will work first with uniform charge densities, which means the charge density is the same at all points on the object. The three charge densities important in this class are: *linear charge density*, the charge per unit length of an object which is a line or a curve; *surface charge density*, the charge per unit area of a charged surface; and *volume charge density*, the charge per unit volume of charged volume.

1.6.2 Geometry

To calculate the total charge of an object whose charge is well described by a uniform charge density, the charge density is multiplied by the appropriate total length, area, or volume. This means we need to recall some basic geometry.

Area of a Circle: The area of a circle with radius r is $A = \pi r^2$.

Circumference of a Circle: The circumference, L , (the distance around the outside) of a circle of radius r is $L = 2\pi r$.

Surface Area of a Cylinder (Excluding Ends): The surface area, S , of a cylinder with radius, r , and length, L , is $S = 2\pi rL$, excluding the ends.

Volume of a Cylinder: The volume, V , of a cylinder with radius, r , and length, L , is $V = \pi r^2 L$.

Surface Area of a Sphere: The surface area, S , of a sphere with radius, r , is $S = 4\pi r^2$.

Volume of a Sphere: The volume, V , of a sphere with a radius, r , is $V = \frac{4}{3}\pi r^3$.

1.6.3 Computing Total Charge from a Density

Summary of Charge Densities: The table which follows summarizes the calculation of the total charge from a uniform charge density.

Region	Density	Total Charge	Pronunciation	Units
Volume, V	ρ	$Q = \rho V$	$\rho \equiv \text{rho}(\text{row})$	$\frac{\text{C}}{\text{m}^3}$
Area, A or S	σ	$Q = \sigma A = \sigma S$	$\sigma \equiv \text{sigma}$	$\frac{\text{C}}{\text{m}^2}$
Length, L	λ	$Q = \lambda L$	$\lambda \equiv \text{lambda}$	$\frac{\text{C}}{\text{m}}$

Example 1.4 Surface Charge Density of a Sphere

Problem: A spherical shell of charge has surface charge density $\sigma = 4\mu\text{C}/\text{m}^2$ and radius $r = 10\text{cm}$. Compute the total charge.

Select One of the Following:

- (a) $5 \times 10^{-4}\text{C}$ (b) $5 \times 10^{-6}\text{C}$
 (c-Answer) $5 \times 10^{-7}\text{C}$
 (d) $5 \times 10^{-10}\text{C}$
 (e) $-5 \times 10^{-7}\text{C}$

Solution

By definition of surface area, the total charge of the shell is $Q = \sigma S$ where S is the surface area. For a sphere, the surface area is $S = 4\pi r^2$, so the total charge is

$$Q = 4\pi r^2 \sigma = 4\pi(0.1\text{m})^2(4 \times 10^{-6} \frac{\text{C}}{\text{m}^2})$$

$$Q = 5 \times 10^{-7}\text{C}$$

Chapter 2

Electric Force I

Science is, at its core, a personal experience. It allows each person the power to find out what is true in the universe. You must believe those parts of science that you have experienced, the things you have touched and the things you have figured out for yourself. In this chapter, we examine features of electric force and charge which we can understand without knowing how to calculate the force.

2.1 Basics of Electric Force

In lab, we found that the electric charge produces a force on charged and uncharged objects. In this section, we examine what can be done with that observation alone.

2.1.1 Qualitative Exploration of Electric Force

I know I can charge something by rubbing it; when I rub a balloon through my hair, I hear tiny crackles like lightning and then I can stick the balloon to a wall. Since gravity would normally tend to make the balloon fall to the floor, there must be another force present between the charged balloon and the uncharged wall. The force is the electric force. Balloons are somewhat a pain to work with, so I went to Wal-Mart and bought a golf club sleeve (referred to here as a “golf tube”), and an oven roasting bag. The golf tube is some kind of soft black plastic and the oven bag is a crinkly clear plastic. You will have met both in lab. If I rub the golf tube with the oven bag, I transfer electrons from the oven bag to the golf tube leaving both with a net charge. The charge on the golf tube is easy to detect since the golf tube will make your hair stand on end. It’s harder to find a convincing way to show the bag is charged, especially when it is humid (where the charge quickly leaks away into the air), but I know that the total amount of charge in the universe is constant, so if the golf tube is charged then the oven bag must have the opposite charge.

I can do a number of things with the golf tube:

- Attract small objects (grass seed, hair, etc.)
- Attract a Styrofoam ball on a string.
- Cause an aluminum can to roll.
- Use it to hold a golf club. (No, that's silly).

At first I thought that electric force acted between two charged objects, but all of these examples are of force between a charged object (the golf tube) and an uncharged object (the other stuff). The reason for the attraction is that grass seed, Styrofoam, etc. are full of positive and negative charges that add up to zero charge (This means they have the same amount of each sign of charge). The electric force from the golf tube acts on all the charge in the uncharged objects and causes the charges to separate slightly.

Next, I wanted to systematically discover the basic principles of electrostatics. To make things as simple as possible, I worked with two charged objects. When we understand those, we can explain the behavior of the uncharged objects by treating them as groups of equal amounts of + and - charge. So I got a second golf tube, rubbed it and put it in a hanger; then I rubbed the first tube. Instead of the first tube attracting the second, the second tube was repelled. So by personal observation: **Like Charges Repel**. Since the only thing I had changed was that the second tube was now charged, and I prepared the two charged rods in an identical way, the repulsion must be a result of the fact that the two tubes have the same charge.

The next step was to get some positive charge, which I (and you) did by rubbing a clear plastic rod with felt. I then found that the golf tube in the hanger was attracted to the charged clear plastic rod, so the clear rod could not have the same kind of charge as the golf tube. This in itself meant nothing since we know that charged things attract uncharged things. I and you prepared a second charged clear rod and that rod was repelled by the first rod, so by personal observation: **There are At Least Two Kinds of Charge and Opposite Charges Attract**. This experiment has been done with many combinations of materials and a charged object which repelled both kinds of charge has never been found. Therefore, there are only two kinds of charge.

Through this experiment we have also observed another important feature of the electric force. Since the two

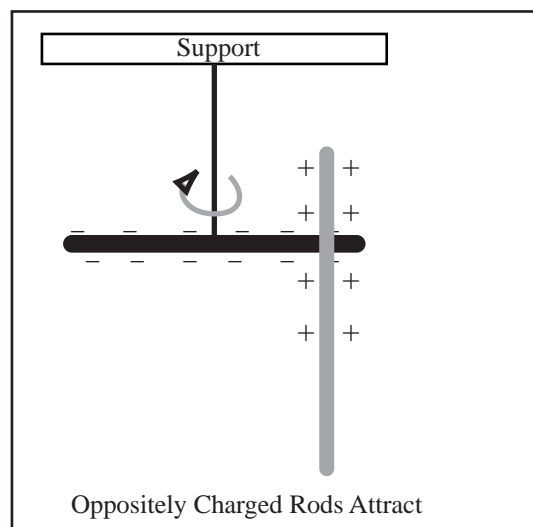
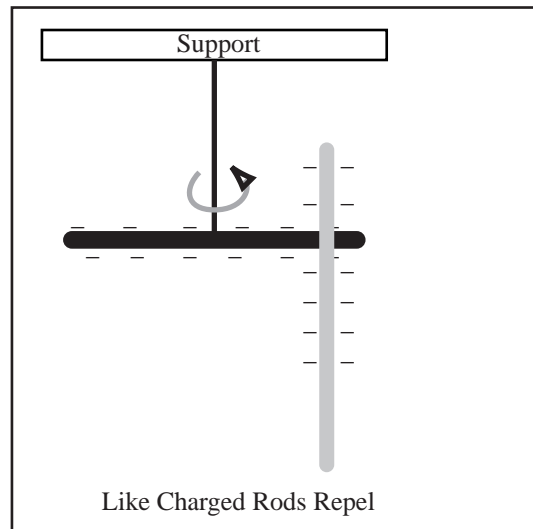
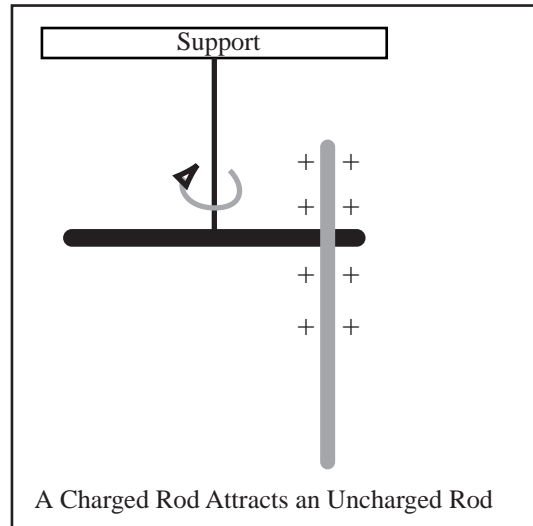

rods had to be close together for anything to happen, we know **The Electric Force Decreases with Increasing Distance**.

Conclusion from Experiments with Charged Rods

- There are at least two types of charges.
- Like charges repel each other.
- Opposite(Un-like) charges attract each other..
- The force between charges falls off with increasing distance.

2.1.2 Properties of the Electric Force

Every object with a non-zero electric charge exerts a force on every other object with a non-zero charge. Therefore, the electron in your wristwatch feels an electric force from a proton in the star Betelgeuse. Properties of the electric force of this proton, however, prevent you from hurtling off towards a distant star. The following is a list of the important qualitative features of the electric force.

The Electric Force Weakens with Distance: As we observed in lab, the electric force between two charged objects gets weaker as the objects get farther apart.

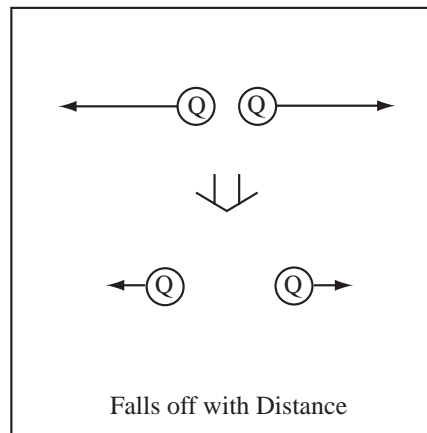

Objects with the Same Sign Charge Repel One Another: If two objects have the same sign charge, there will be a repulsive, outward force between the objects.

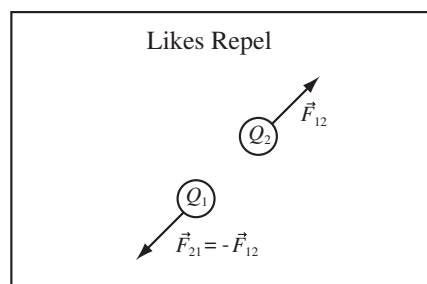

Oppositely Charged Objects Attract One Another: If one object has a negative charge and another object a positive charge, there will be an attractive, inward force between the objects.

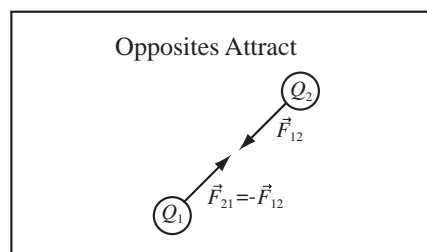

Electric Force Acts Along the Line through the Centers of the Charges: The direction of the electric force will either be inward or outward pointing along the line that connects the two charges.

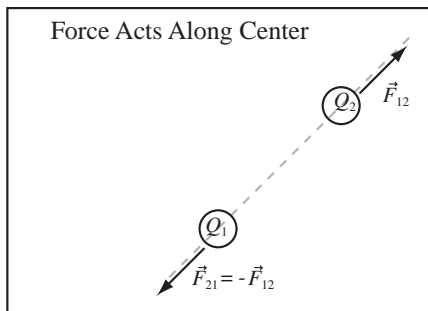

The Electric Force Adds Like a Force: The electric force is just another force. The electric force from two objects can be added using Newton's Second Law, just like in mechanics. The electric force can be added to other types of forces such as the gravitational force or a frictional force.

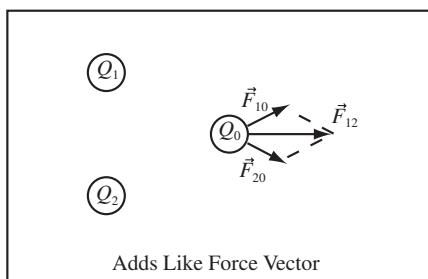

Newton's Third Law Applies to the Electric Force: The electric force, \vec{F}_{AB} , an object A exerts on an object B is equal and opposite to the force, \vec{F}_{BA} , that object B exerts on the object A . ($\vec{F}_{AB} = -\vec{F}_{BA}$)

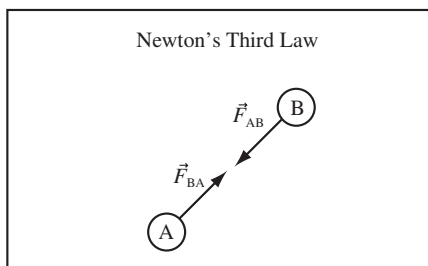

We will shorten the second and third points to *Opposites Attract, Likes Repel* and use it until you're sick to death of it. So back to the proton in Betelgeuse. The first property, that force falls off with distance, implies that the electric force of a charged object will exert a very small force on a distant object. Betelgeuse is 600 light years away, so the force from one proton is pretty small. Further, Betelgeuse, like everything else in the universe, is nearly electrically neutral, so the force of the proton is cancelled by an equal and opposite force from an electron.

2.2 Effect of Electric Force on Materials

A conductor is a material through which net electric charge can travel distances larger than the size of an atom. An insulator is a material through which charge cannot move. An insulator is also called a *dielectric*. If a region of net charge is placed on a conductor, it will quickly spread to cover the entire surface. If a region of net charge is placed on an insulator, the charge will remain where it was placed.

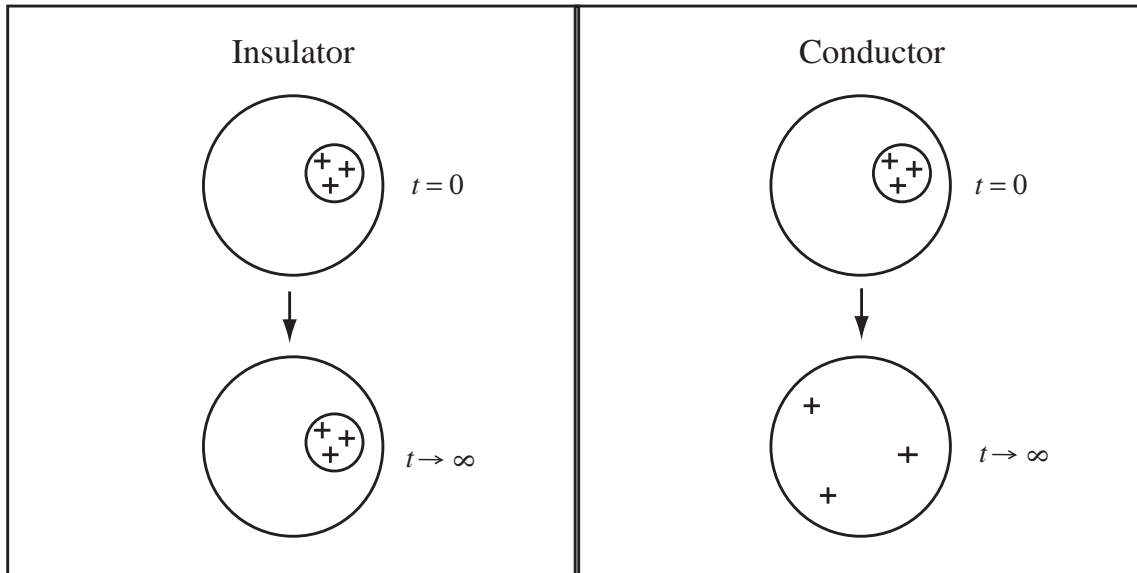

This is why it is so hard to use the golf tube, which is an insulator, to directly transfer charge to anything; but it is easy to transfer charge using an electrophorus (Course Guide 3), since the plate is a conductor. Net charge spreads over a conductor very quickly, so using the instruments of this class we will not be able to observe the spreading process. Instead, we will always observe the conductor in its final state. Often an insulator is used to cover the surface of a conductor, this is called insulation. In your house wiring, the insulation takes the form of a plastic coating on the wires. In lab, a varnish will insulate the wires. Air is an insulator in most circumstances, but will allow charge motion if a lot of electric force is applied. A spark is electric charge moving through the air.

2.2.1 Effect of Electric Force on Materials

With our general understanding of electric force, that it falls off with distance and opposites attract/likes repel and our understanding of conductors and insulators, we can begin to understand how *net* charge behaves in materials. At the atomic level, conductors and insulators are about the same—a bunch of atoms held together in some manner. The atom is a collection of positively charged protons and electrically neutral neutrons with negatively charged electrons orbiting the nucleus. The difference between conductors and insulators is the ability of some of the electrons to move freely from atom to atom in a conductor. Electrons are not free to move in an insulator, except interior to the atom. This means that electrons can move across a conductor in response to electric force, but electrons in an insulator are stuck to their respective atoms.

Consider the behavior of a net charge placed on a conductor. Suppose a small patch of charge is sprayed on the inside of a metal conducting bucket. Where will the net charge be a short time later?

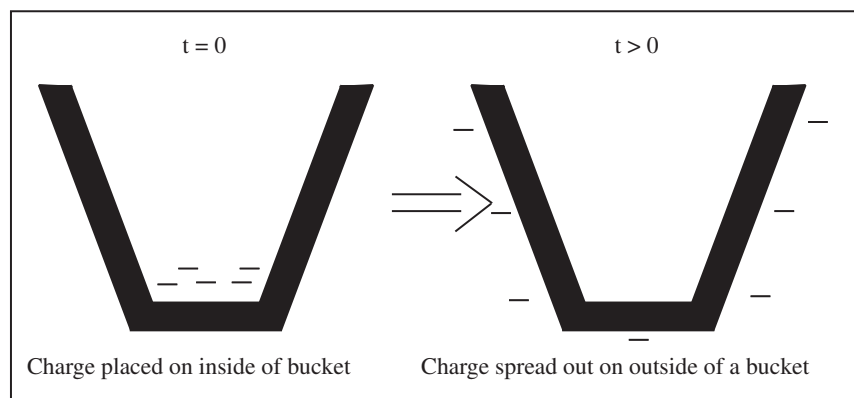

Since the charges forming the net charge are all of the same sign, the charges, in this case electrons, will repel each other, pushing each other as far apart as they can get. In a very short time, the electrons spread out on the

outside of the bucket as far apart as they can get. What would happen if the same experiment was done with an insulator, spraying charge on the interior of a plastic bucket? The charges would stay where they were placed. The behavior of the electrons on the conducting buckets leads to our first two principles of how electric charge behaves in a material.

Net Charge Spreads out on the Outer Surface of Conductors: Because like charges repel, charges try to get as far apart as possible, so charge spreads out on the outer surface of a conductor.

2.2.2 Effect of Electric Force on a Charged Conductor

Consider the action of the electric force at a distance. If a negatively charged object (a golf tube) is brought near a negatively charged conductor, the negatively charged tube will repel the negative charges on the conductor and they will move away from the tube until the force exerted by the other negative charges on the conductor balances the force exerted by the tube. Since the charges can't escape the conductor, the force on the charges is communicated to the conductor, and the negatively charged conductor feels a repulsive force, \vec{F}_{tc} , from the negatively charged golf tube. Likewise, the golf tube feels a repulsive force from the negatively charged conductor, $\vec{F}_{ct} = -\vec{F}_{tc}$, but the charges on it are stuck, so they don't move around on the tube. The opposite happens if the conductor is positively charged, as you can see from the following figure.

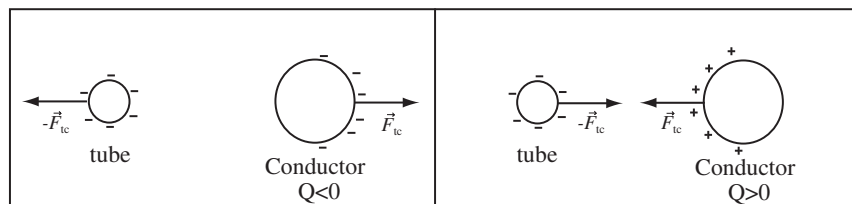

Net Charge Moves In a Conductor in Response to an External Electric Force:

If a conductor is given a net charge and brought near another charged object, the net charge on the conductor will move either farther away if it has the same sign as the external charge (Likes Repel) or nearer if it has the opposite sign as the external charge. The net charge will still be at the surface of the conductor. The net charge on an insulator does not move through the insulator in response to an electric force.

2.2.3 Charge Sharing

Consider the two conductors with opposite charge shown in the figure below. The conductors are connected by wire with a switch which is open and does not allow the charges to mix. Conductor 1 has a slight excess of electrons. These excess electrons are spread over its surface to get as far apart as possible. Conductor 2 has a slight deficit of electrons, and the atoms which are missing the electrons are near the surface. It is perfectly acceptable to visualize conductor 2 with a mobile set of + charges.

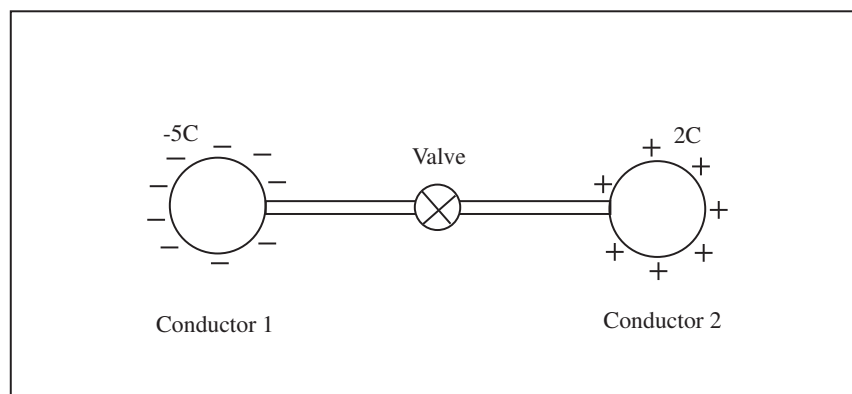

What happens when the valve is opened allowing the charge to mix? Since positive charge attracts negative charge, the positive and negative charge will get as close together as possible—excluding the charges that cannot find mates.

$$\sum Q_{initial} = -5C + 2C = -3C = \sum Q_{final}$$

Therefore, once the valve is opened we will have the following

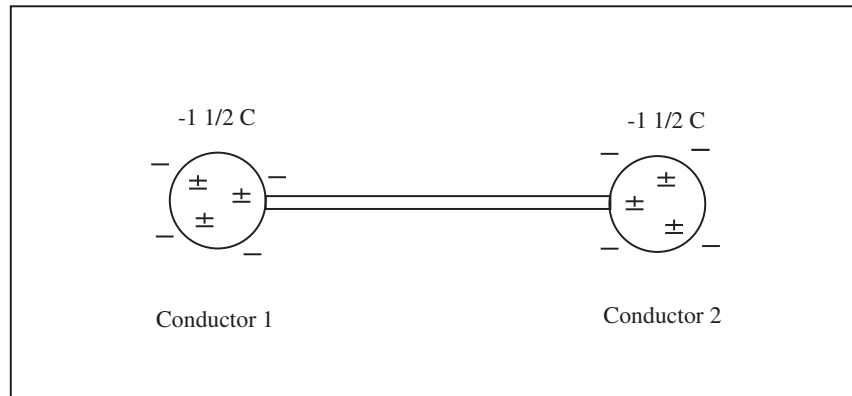

If the objects are identical, we would have $\frac{Q_{final}}{2} = -\frac{3}{2}C$ on each sphere. The other + and - charges were not destroyed, but are paired up with a + charge very close to a - charge. In most processes, the total number of electrons and protons remains the same. In ALL processes, the total charge is conserved.

Charge Sharing: If two conductors are placed in electrical contact, any net charge on either conductor will spread out on both conductors. This will be called *charge sharing*.

2.2.4 Charge Separation on a Conductor

Now consider a neutral conductor in the presence of a charged object, a soda can for example. The electrons in the conductor can still move, so the negatively charged electrons are pushed away from the negatively charged tube, leaving a net positive charge behind. The total charge on the can is still zero. This process will be called *charge separation*. A neutral soda can in the presence of a negatively charged golf tube is drawn below. The charge on the can separates due to the external electric force of the golf tube. The electric force decreases with increasing distance, so the force, $\vec{F}_{tube,+}$, that the positive charges on the surface of the conductor experience is stronger than the force, $\vec{F}_{tube,-}$, that the negative charges feel, $|\vec{F}_{tube,+}| > |\vec{F}_{tube,-}|$. Therefore there is a net attractive force between the tube and the neutral conductor, as drawn below.

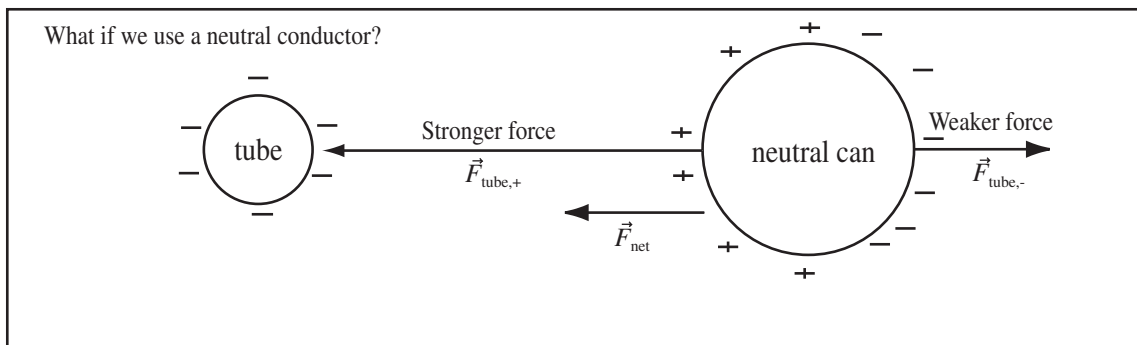

Charge Separation on a Conductor: If a neutral conductor is brought near an object with fixed charge, the mobile charge in the conductor will move until the net electric force inside the conductor is zero. The like charges move away from the charged object and the opposite charges move toward it. This process will be called *charge separation*.

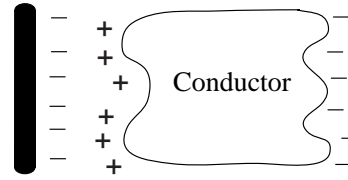

2.2.5 Polarization of an Insulator

What if we use a neutral insulator? The charge cannot move large distances in an insulator, but the electrons and protons are still affected by the electric force. Each atom is affected by the electric force, causing the electron cloud to shift slightly leaving the center of like charge farther away and the center of unlike charge nearer the external charge.

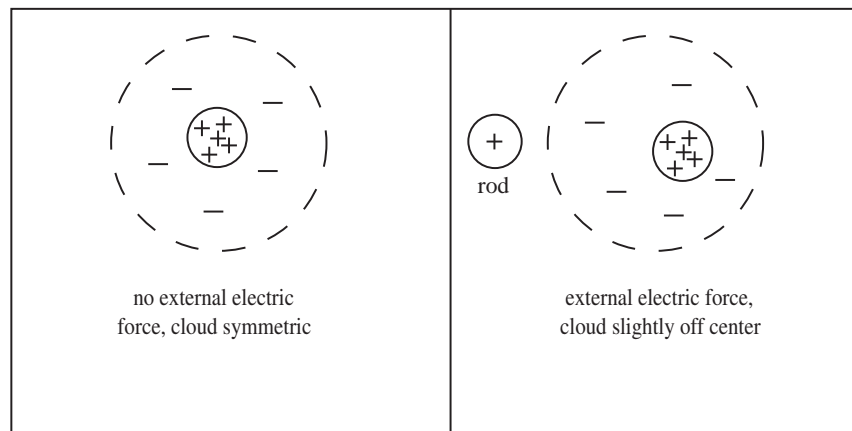

This causes a surface charge density in a neutral insulator when immersed in an external electric field. This effect is called *polarization*.

Polarization of a Dielectric: If a dielectric is brought into the field of a fixed charge, atomic charge separates slightly producing a surface charge density as drawn to the right. Unlike charge separation in a conductor, no charged particle has moved more than the distance across one atom.

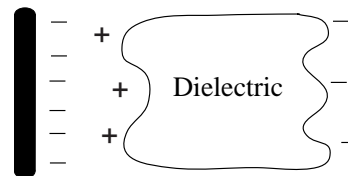

There is still an attractive force between a charged object and an uncharged insulator. The induced surface charge density on the insulator is equal and opposite, but the electric force falls off with distance causing a net attractive force as shown below.

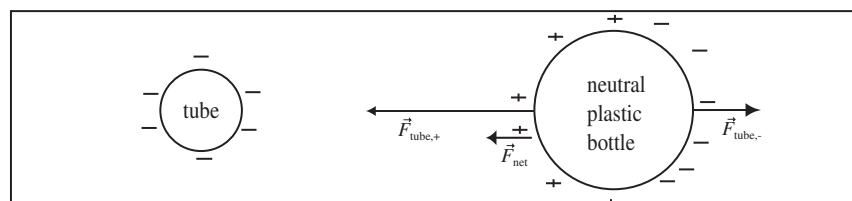

2.2.6 A Charged Object Attracts an Uncharged Object

Since both neutral conductors and insulators are attracted by a charged object and every material is either a conductor or an insulator, we can state:

A Charged Object Attracts an Uncharged Object: Because of the polarization of insulators and charge separation on neutral conductors, a charged object attracts any uncharged object.

The amount of surface charge produced by charge separation in a conductor is larger than the amount of surface charge produced by polarization of an insulator (dielectric), so the force a charged object exerts on an uncharged conductor is larger than the force it exerts on a similarly shaped insulator (dielectric).

Example 2.1 Picking Up Paper with a Balloon

Problem: After rubbing a balloon in your hair, you can use it to lift small pieces of paper off a table. Explain.

Solution

When I rub a balloon in my hair, charge is transferred to/from the balloon from/to my hair and it acquires a net charge. The net charge on the balloon causes the charges in the atoms of the insulating paper pieces to polarize slightly leaving (assuming a negatively charged balloon) some excess negative charge farther from the balloon and some excess positive charge nearer to—as shown to the right. The electric force falls off with distance so that the positive charges nearer the balloon feel a larger attractive force than the repulsive force felt by the negative charges on the paper farther from the balloon, giving a net attractive force between the balloon and the pieces of paper.

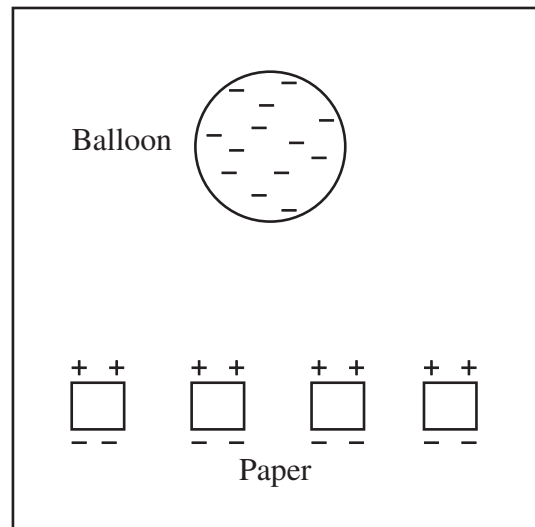

2.2.7 Charging by Charge Separation

The same physics involved in charge separation can be used to produce conductors with equal and opposite charges. Begin with two neutral conductors which are in electrical contact either connected by a wire or touching. Bring a charged object near and there will be charge separation. If the connection is broken, objects of equal but opposite charge are produced, by conservation of charge.

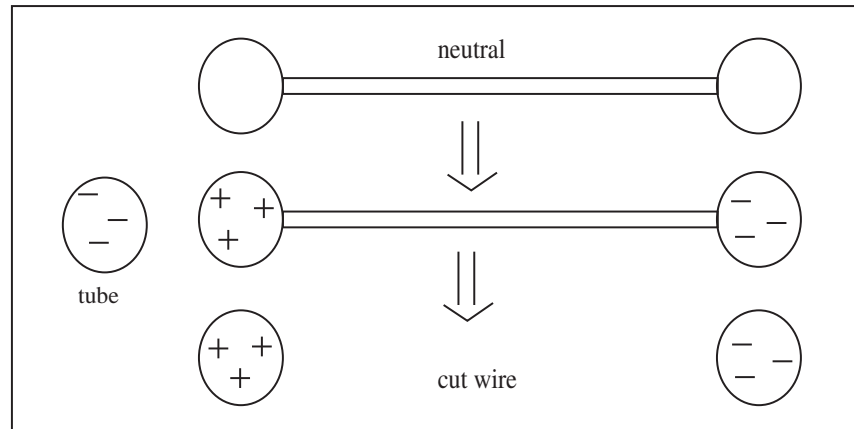

2.3 Capacity and Grounding

2.3.1 General Discussion of Capacity

Last chapter and earlier in this chapter we connected two identical conductors and argued that the charge on the conductors would be shared equally between the conductors. This is a general principle, that if N identical conductors are arranged symmetrically with no external fixed charge anywhere near, the charge will share equally among the N conductors. Now, consider connecting two spheres of different sizes, each with net charge Q .

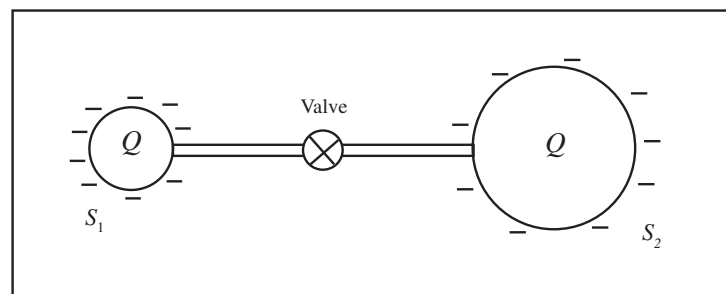

First consider the system before the valve is opened. Because S_2 is larger than S_1 , the electrons carrying the net charge of sphere S_2 are farther apart than those in S_1 . Like charged objects push on one another (repel) and that force decreases with distance. Therefore, since the charges on S_1 are closer together than the charges on S_2 , they feel a larger electric force pushing each other apart. That is, they feel a larger electric pressure. What happens when we open the valve?

The charges in S_1 and S_2 both feel a force pushing each other apart and into the wire connecting the spheres, but the charges in S_1 feel a much greater force than the charges in S_2 . So some of those charges will be pushed from S_1 to S_2 until this force equalizes, leaving $Q_1 < Q_2$. S_2 holds more charge than S_1 if they are connected by a wire. We will call the amount of electric charge an object can hold its *capacity* and learn to compute it in a few weeks.

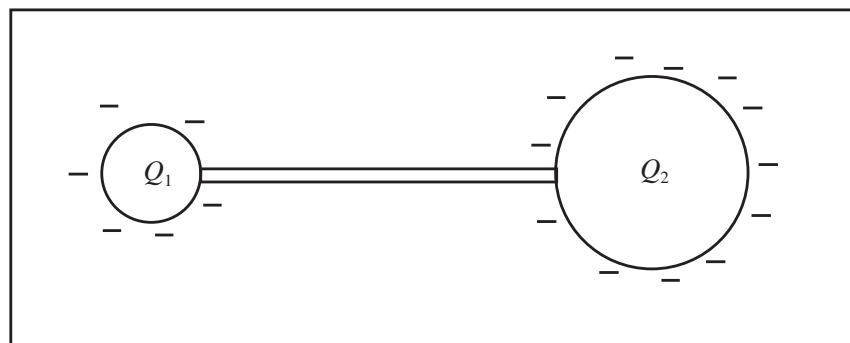

Approximate Capacity for Spherical Conductors: For spherical conductors S_1 and S_2 ,

$$\frac{Q_1}{Q_2} = \frac{R_1}{R_2}$$

where R_1 and R_2 are the radii of S_1 and S_2 and Q_1 and Q_2 are their charges if connected by a wire far from any fixed charge. Since this is physics, we will use this as a general approximation for any object where we can't actually compute the capacity.

2.3.2 Grounding

In most applications, a net static charge is a very undesirable thing. So we would like to have a way to remove a net charge from a system. For an insulator, we're out of luck. You just have to try different things (like washing the system in water) to remove the charge. To remove charge from a conductor, we can use the fact that charge is shared unevenly between conductors of different sizes. If a conductor is connected to a *much* larger conductor, almost all of the net charge will move to the larger conductor. The largest conductor available is the earth, with a radius of $R_{earth} = 3,963$ miles. If a conductor with a net charge is connected to the earth, the charge will be shared in the ratio

$$\frac{Q_{conductor}}{Q_{earth}} \approx \frac{R_{conductor}}{R_{earth}} \approx 0 \Rightarrow Q_{conductor} \approx 0$$

so the earth absorbs most of the charge. In lab, we have been removing charge from electroscopes and electrophoroi by touching them. When we do this, our body becomes the large conductor, and we make the approximation

$$\frac{R_{conductor}}{R_{us}} \approx 0.$$

The objects in lab involve relatively small amounts of charge. For larger charges or larger objects, it is best to remove the charge by electrically connecting them to the earth. This is called *grounding*.

The earth is filled with water, if you dig a bit, but it is a rather poor conductor in general, so you have to work to form a good ground. If a wire is touched to earth, the place where contact is made may be insulating because it's dry or a rock and a poor connection will be formed. To form a good connection, a long conductor is used. In a house, an 8ft steel pole is driven into the earth.

Electrical Symbol for Ground: A ground in an electrical circuit is represented using the symbol to the right.

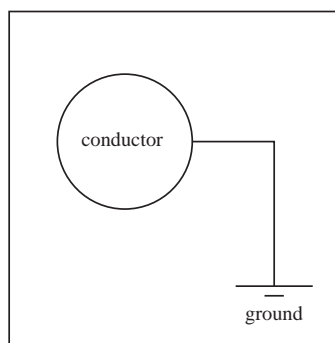

Example 2.2 Grounding My Daughter

Problem: After playing on our trampoline, my younger daughter's hair stands on end. When she touches the metal frame there is a spark and her hair no longer stands up. Explain.

Solution

(a) As she jumps on the trampoline, her feet rub the fabric of the trampoline and charge (assumed to be negative for this discussion) is transferred to her. The charge distributes on the surface of her body, even to the surfaces of her hair. Since the strands of hair now have like charge, they repel one another so her hair stands up.

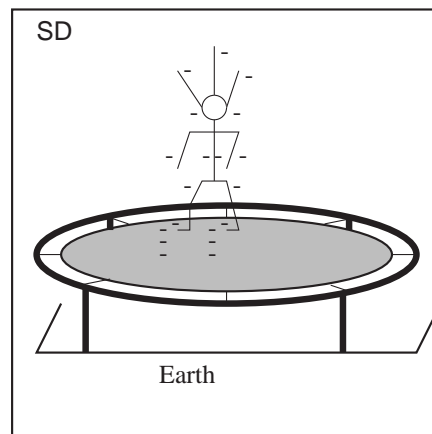

(b) When she touches the metal, the excess charge is transferred through the frame to Earth — the spark is the visible evidence of this charge transfer. Since she is not charged, her hair returns to normal.

2.4 Shielding

2.4.1 Shielding Effect of a Conductor

When a charged object is brought near a conductor, the charge separates slightly on the conductor. The amount of charge which separates is very small compared to the amount of charge available.

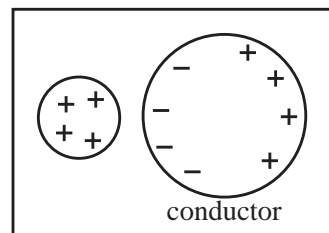

The separated charge will not usually exceed a $1\mu\text{C}$, whereas the available atomic charge is on the order of $1 \times 10^5 \text{C}$.

Why doesn't all the available atomic charge separate? Let's build up the separated charge one electron at a time and examine the force felt by the next electron to be added to the separated charge. The net force on the first electron is the full electric force, \vec{F}_Q , of the external charge. The net force on the second electron which moves to the surface is the sum of the external electric force \vec{F}_Q to the left AND the electric force \vec{F}_{e_1} to the right from the first electron separated AND a force, \vec{F}_{p_1} , to the right from the positively charged region left behind by the first electron. Therefore the force from the first charge added to the separated surface charge partially cancels the external electric force. The total shielding force due the first electron is represented as \vec{F}_{s1} in the middle figure. The size of \vec{F}_{s1} is greatly exaggerated. As more charge separates, the electrons (and protons) in the interior of the conductor feel progressively less NET force, because the force from separated charges partially cancels the externally applied force. The charge separation continues until the external force is completely cancelled by the electric force, \vec{F}_{sN} , of the separated charge as shown in the third figure. The electrons in the interior of the conductor then feel zero net electric force.

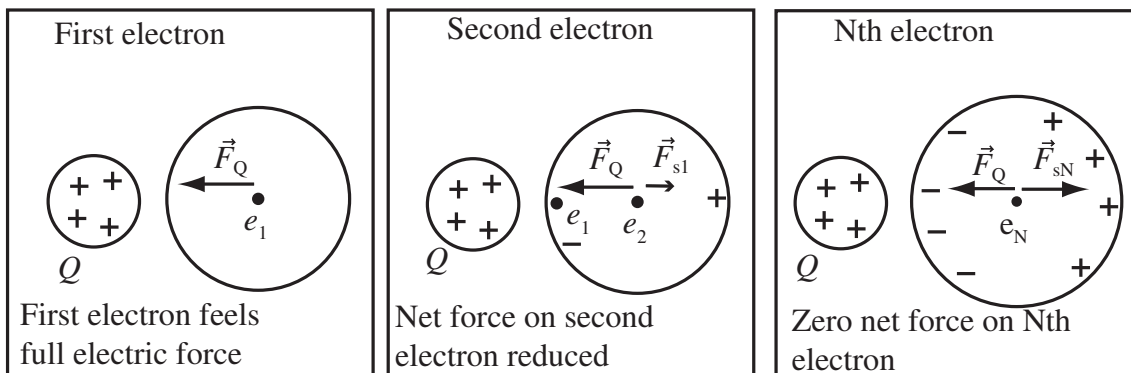

The Inside of a Conductor is Shielded from the Electric Force: The mobile charge inside a conductor feels no net electric force because the separated surface charge cancels the external electric force. This effect is called *shielding*.

From this analysis, we can estimate that the amount of charge separated is not more than the external charge, and probably much less.

Amount of Shielding Charge: Since the separated surface charge is closer to the conductor than any external charge, it can be assumed that the amount of separated charge is not greater than the external charge. If the external charge causing charge separation is very near the conductor, the separated charge will be on the order of the external charge.

This effect is very useful. It means the surface charge density on a conductor due to charge separation produces zero electric force inside a conductor, thus shielding the interior of the conductor from the electric force. Many instruments and devices are adversely affected by electric forces, so this shielding effect is very useful. Therefore, if we place a charge inside a hollow space in a conductor, it will feel zero electric force from the outside world.

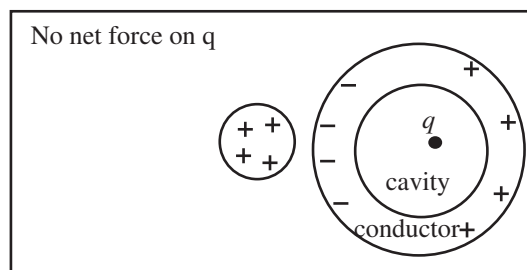

Net Charge Placed Interior to a Hollow Conductor is Shielded from External Electric Forces: If a fixed charge is placed inside a hollow space in a conductor, it will feel zero net electric force from all charges exterior or on the surface of the conductor.

Example 2.3 Shielding of Electric Force by Bucket

Problem: Consider the situation to the right where a charged pith ball is suspended from a string inside a conducting bucket. A charged golf tube is brought near the conducting bucket.

- Draw the charge the golf tube causes to separate on the conducting bucket.
- Describe the net force exerted on the pith ball. Tell how your choice of force is consistent with Coulomb's Law which states that every charged object exerts a force on every other charged object.

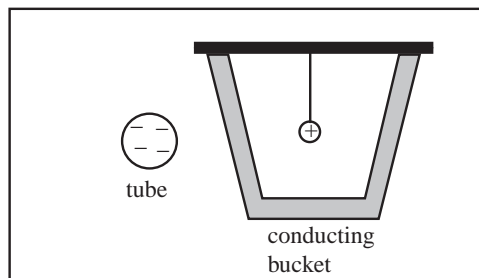

Solution to Part(a)

Because charge can move in a conductor and like charges repel/opposites attract, the electric force of the golf tube attracts positive charge to it and repels negative charge from it to produce the distribution of charge on the outside surface of the conductor as drawn.

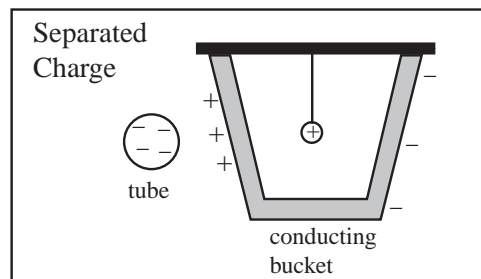

Solution to Part(b)

The pith ball feels zero total electric force. The pith ball still feels the electric force from the golf tube, but this is cancelled by an equal and opposite electric force from the separated charge on the bucket.

2.5 Charging by Induction

2.5.1 Charging by Induction

In the discussion of charge sharing and grounding, there was no fixed charge near the system. That is, there was no net charge that was trapped and could not either flow to another location on one of the conductors or flow to the ground.

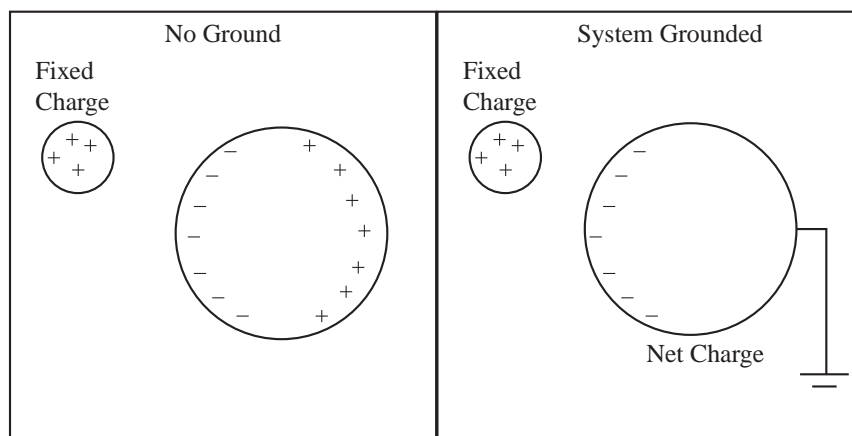

In the picture at the left above, charge separates until the interior of the conductor feels zero net electric force. The separated negative charge is held in place by the fixed charge. The separated positive charge is mostly shielded from the force of the fixed charge and is not held in place. When a ground is connected, the positive charge is free to escape to the ground and greatly increases its separation. Note: for you atomists, what happens atomically is that negative electrons are drawn from the ground to neutralize the region of net positive charge. If the ground is disconnected while the fixed charged object is still near, the conductor will have a net charge.

Definition of Charging by Induction: An object is said to be *charged by induction* if a fixed charge is brought near a neutral conductor causing charge separation and the conductor is then grounded, removing separated charge not held in place by the fixed charge, thus leaving a net charge on the conductor.

In charging by induction, the charge that escapes to the ground is not pushed away by the fixed charge, it is simply not held in place and so is free to move farther away by moving to the ground. This means the amount of charge we produce on an object is approximately the amount of charge needed to shield the interior of the

conductor from the electric force, so by our argument before, it should be of the same order of magnitude as the fixed charge if it is close to the conductor.

The following example illustrates the escape of the untrapped charge a little more clearly. Remember there is plenty of free atomic charge available at all points in a conductor, it is not just the small number of + and – we draw on the figures that are in play.

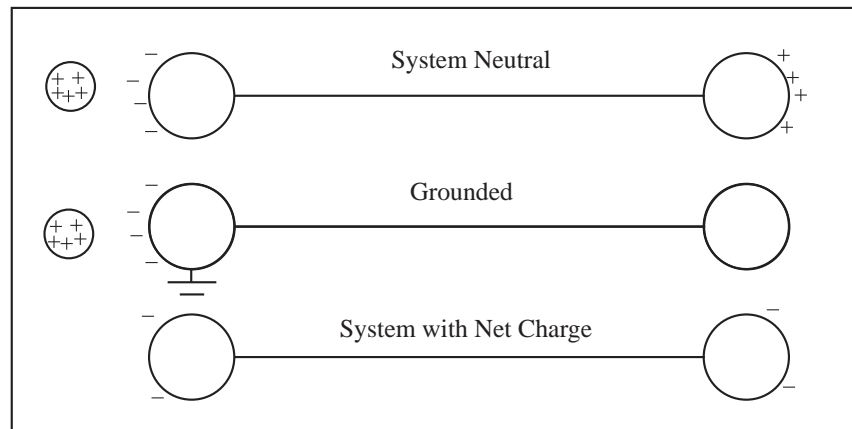

2.6 Obtaining a Net Charge

Most people have experienced the effects of a net static electric charge including sparks, hair standing on end, and static cling. What follows is a partial list of ways to produce a net static charge:

Charging by Friction: When two materials are rubbed against one another, there is sometimes a charge transfer between the two materials. For example, you can charge a balloon by rubbing it in your hair. My daughter is charged by jumping on a trampoline. My car is charged when I drive it through dry air and I can charge my clothing by rubbing it against the dryer walls.

Charging by Adhesion: Sometimes when two objects are stuck together, like two pieces of tape or two sheets of foam insulation, pulling them apart will transfer charge from one to the other.

Charging by Spraying Charge or Sparking: An object can be charged by spraying it with charged particles. The earth is bombarded with charged cosmic rays. A pool can be charged by a bolt of lightning. The screen of your TV is charged by the electrons sprayed on it by the cathode ray tube.

Charging by Induction: A conductor can be charged by holding some of its charge in place with another charged object and allowing the opposite charge to flow to ground.

Charging By Pumping Charge: The easiest and most common way to move charge is to pump it between two conductors, or between the earth and one conductor. A battery is a charge pump. We use the more exotic charging mechanisms in lab because it is hard to develop a net charge whose force is observable using safe voltages.

Charging by Separation: A pair of objects can be given equal and opposite charges by placing them in contact and causing their charge to spread by using a charged object, and then separating the objects.

2.7 Summary

2.7.1 Summary of the Basic Principles of Electrostatics

Before continuing let's gather together the main principles used in analyzing the behavior of electrostatic systems.

Charge is Conserved:

Charge Moves in a Conductor and does not Move in an Insulator:

Opposites Attract/Likes Repel:

Electric Force Decreases with Increasing Distance:

Charge is Shared Between Conductors in Electrical Contact:

Charge Separates on a Conductor in Response to an Electric Force:

An Insulator Polarizes in Response to an Electric Force:

Charge is Shared Unequally Among Conductors of Difference Sizes:

The Interior of a Conductor is Shielded from the Electric Force:

2.7.2 Placing the Charge You Want on a Conducting Sphere

The simplest illustration of some of these principles comes from playing with conducting marbles.

Sphere's with Equal Charge: To produce a set of identical conducting spheres all with equal charge, charge up a conducting sphere (a ball bearing or steel marble for example) and call the charge on it Q . If you touch it with an uncharged conducting sphere of the same size, the charges equalize between the two spheres and afterward each sphere has a $\frac{1}{2}Q$ charge.

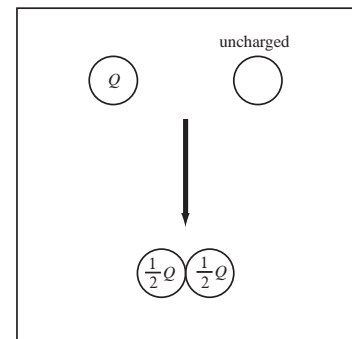

In the same way, if you want $\frac{1}{3}Q$ you can take three uncharged spheres and put them in a triangle. So if you wanted charges $2q$ and $3q$ you could do the following: 1. Charge up a single ball with a charged rod or by touching it to the Van de Graaff generator. 2. Split that charge into two equal charges Q by touching the charged ball with an uncharged ball. 3. Divide Q in half and in thirds as in the previous examples, which gives you charges $\frac{1}{2}Q$ and $\frac{1}{3}Q$. Define $q = \frac{1}{6}Q$ and you have $\frac{1}{2}Q = 3q$ and $\frac{1}{3}Q = 2q$.

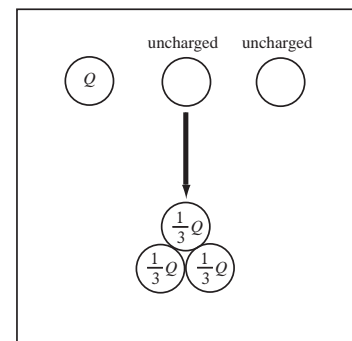

The symmetry is crucial because in the three spheres placed in a line at the right, to get as far apart as possible most of the charge will be on the two outer spheres leaving less charge on the center sphere. We could conclude the spheres on the ends have the same charge by symmetry.

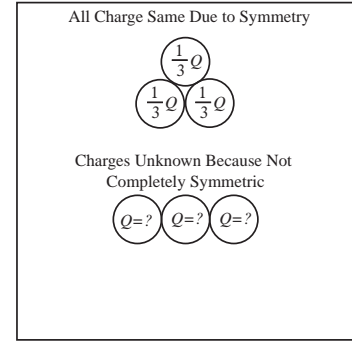

We use the same size spheres because the charge is free to move in a conductor, so there is no reason for the charge on two identical conducting spheres to be different. If, however, we use two different size spheres, the charge will be greater on the larger sphere.

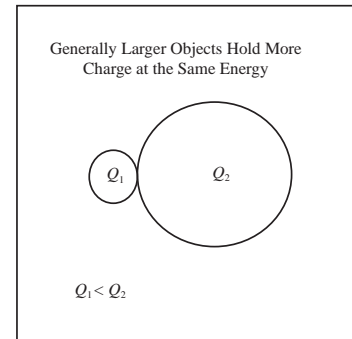

Great! So what if I need $+q$ and $-q$. Take two uncharged conducting spheres and put them in contact near the charged golf tube.

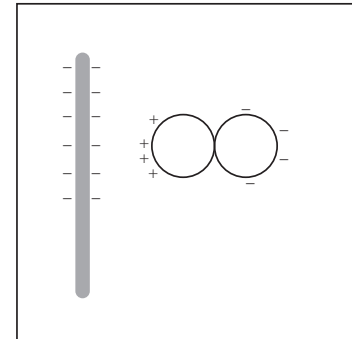

Now move the spheres apart and the total charge of the two spheres must be zero (since we didn't touch the spheres with the golf tube, they still have the same TOTAL charge they had at the beginning).

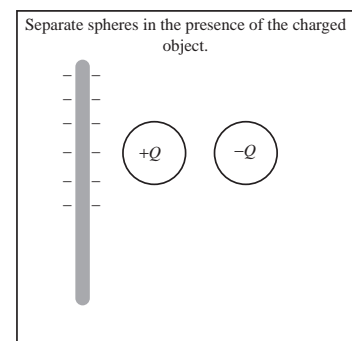

Example 2.4 Charging Marbles

Problem: You are given 3 identical uncharged conducting marbles and a negatively charged golf tube. You do the following:

- (i) Bring the golf tube near marble A and ground the marble. Remove the ground before removing the tube.

(ii) Without loss of charge, bring marbles A and B into contact, then separate them.

(iii) Then without loss of charge, bring marble C into contact with marble B .

The final charges are, if marble A was given a charge $+Q$ in step (i):

Select One of the Following:

(a) $Q_A = Q_B = Q_C = Q/3$ (b) $Q_A = Q/4, Q_B = Q/2, Q_C = Q/4$ (c) $Q_A = Q, Q_B = Q/2, Q_C = -Q/2$ (d) $Q_A = Q/4, Q_B = Q_C = Q/8$ (e-Answer) $Q_A = Q/2, Q_B = Q_C = Q/4$

Solution

In step i, the marble is charged by induction to a charge of $+Q$. In step ii, the identical spheres are brought in contact and they share charge equally, $Q_A = Q_B = Q/2$. In step iii, the two spheres share the charge equally leaving $Q_A = Q/2, Q_B = Q_C = Q/4$, so the answer is (e).

Chapter 3

Electrostatic Devices

At the end of Course Guide 2, we illustrated some of the basic features of the electric force and its action on a conductor with some experiments with identical conducting spheres. Unfortunately, these will have to remain thought experiments since the charge developed on the marble is too small to detect. In lab, we will construct two classic electrostatic devices used by early experimenters to produce large net charges, the electrophorus, and to detect small net charges, the leaf electroscope.

3.1 Electrophorus

We would like to build something which places a large net electric charge on a conductor, so that charge could easily be transferred to whatever we want. We know that we can place a large net charge on an insulator. Using the insulator we can charge a conductor by induction. We have reasoned that since the electric force decreases with increasing distance, the amount of charge produced using charging by induction depends on how close the fixed charge is to the conductor to be charged. It also seems reasonable that the total charge produced should depend on the total area of the conductor brought near the insulator. Therefore, to produce a large net charge using charging by induction we need to bring a large surface of a conductor very near a fixed charge. We can do this by charging a flat insulating (plastic) plate and placing a flat piece of metal on it. The charge in the metal separates. If the metal plate is grounded while sitting on the plastic, it will obtain a large net charge. This device is called an *electrophorus*.

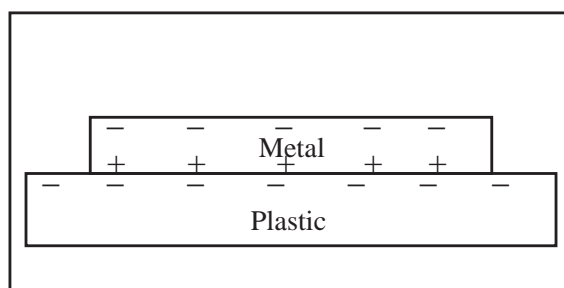

To build my own electrophorus, I used an acrylic cutting board for the flat plastic plane and a pie pan. In lab you used a piece of blue foam wallboard for the plastic plane. I put an insulating handle on the metal, a large plastic spice container, otherwise as soon as I picked it up I would have grounded it. The way I finally put it together is shown at the right. (Some tape is slightly conducting, so if your electrophorus does not work, try different tape or glue.)

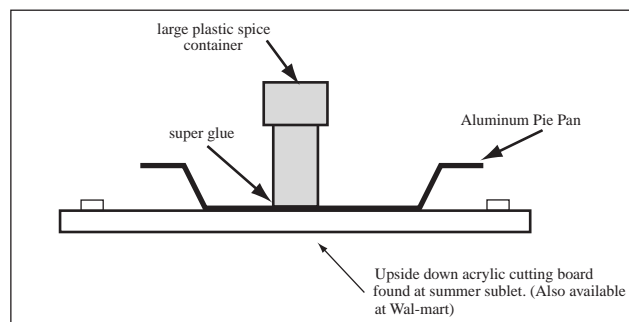

The electrophorus is charged by induction using our body as the ground. To charge the electrophorus, I rub the cutting board with the oven bag. I put the pie pan on the charged plastic board and grounded it with my finger. I felt a spark when I grounded it. I picked up the plate (by the handle) and tried to ground it again, and I felt a spark. Here's a picture of what happened:

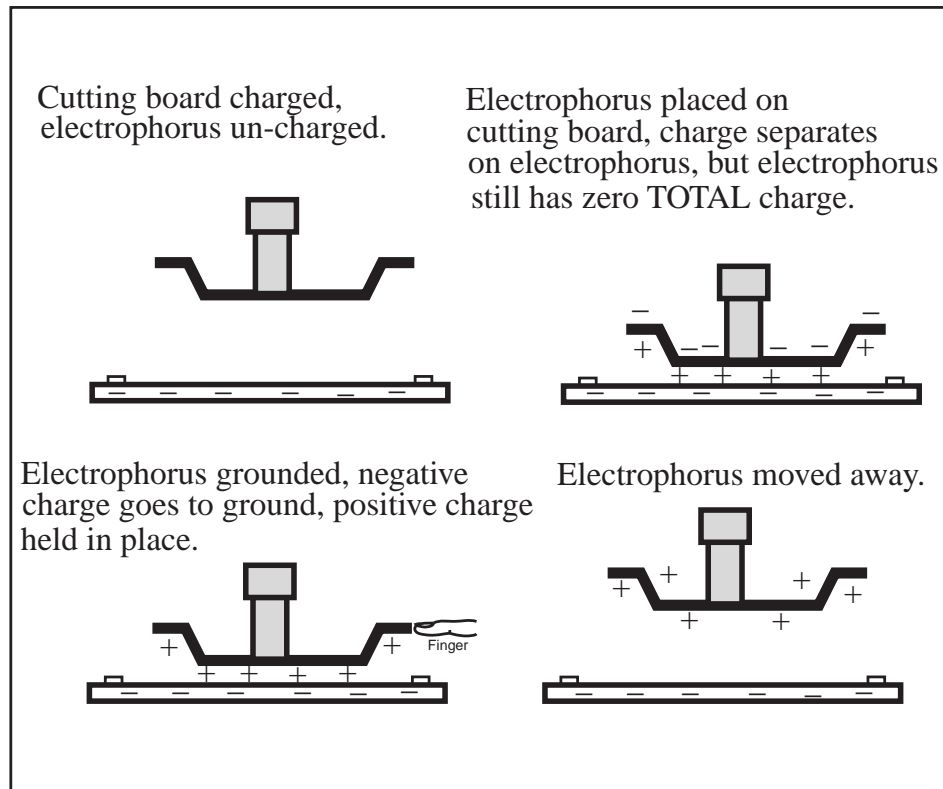

Since the metal plate is so close to the fixed charge on the insulator, it is a good approximation that the charge density on the electrophorus is equal and opposite where the electrophorus makes contact with the insulating board. The net charge produced on the electrophorus by charging by induction is then the charge density of the insulating plate multiplied by the area of the electrophorus that makes contact with the plate. The sign of the charge of the electrophorus is opposite that of the fixed charge on the insulator. You will understand this quantitatively in Course Guide 9.

Example 3.1 Why Positive Charge on the Electrophorus?

Problem: In terms of basic electrostatic principles, why do you produce a positively charged electrophorus when you touch the pie pan sitting on the negatively charged Styrofoam board. Draw a picture of the electrophorus and board before and after you touch it.

Solution

Since charge can move in a conductor and like charges attract/opposites repel, when the pie pan is placed on the charged board, opposite (+) charges move close to the board and like charges (-) move farther away → Charge Separation. When the pie pan is touched, the positive charges are held in place by the electric force of the cutting board, but the negative charges are free to move. Since like charges repel, the - charges will try to get as far apart as possible. Since a human body is a larger conductor than the pie pan, the charges can get farther apart by spreading out mostly over the larger conductor, so - charges are transferred from the pie pan to the person touching the pie pan leaving it positive.

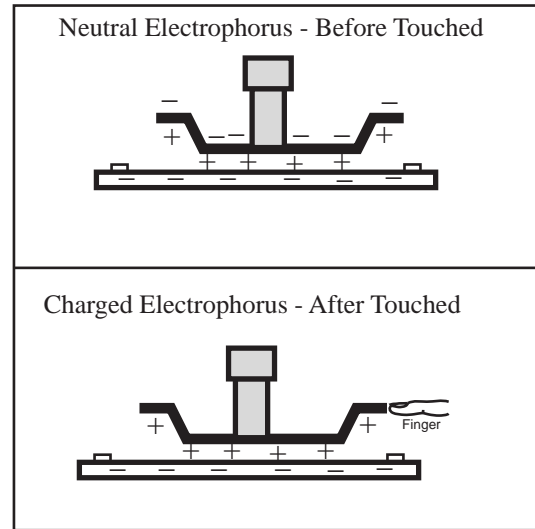

The behavior of the leaf electroscope charged with the electrophorus when a negatively charged golf tube is brought near that you observed in lab indicates the electrophorus charges positive and the wallboard negative.

3.2 Leaf Electroscope

3.2.1 Building and Using a Leaf Electroscope

An *electroscope* is a device for detecting the presence of net charge. We will work with two electroscopes in this class: the leaf electroscope and the pith ball electroscope. A diagram of a leaf electroscope is shown to the right. The aluminum foil is loosely hung on the loop of copper wire. When you charge the electroscope by touching the bolt with a charged conductor, the charge goes equally onto each of the two aluminum foil strips and forces them apart (reason: like charges repel). The jar keeps the leaves from blowing around. The metal casing on the glass jar shields the foils from external electric forces. The bolt conducts charge to the foils. I cheated when I made mine because the physics department had a few broken electroscopes, so I got the jar and bolt for free.

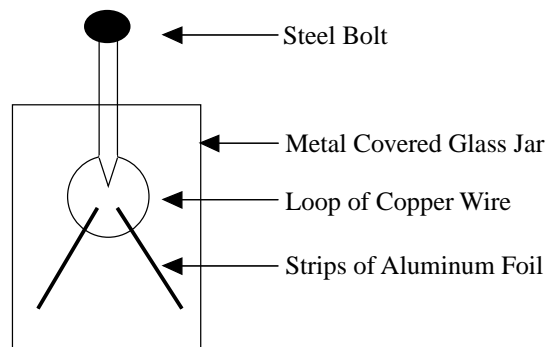

When I brought a charged object (shown as the electrophorus in the diagram) near the electroscope, I observed the following:

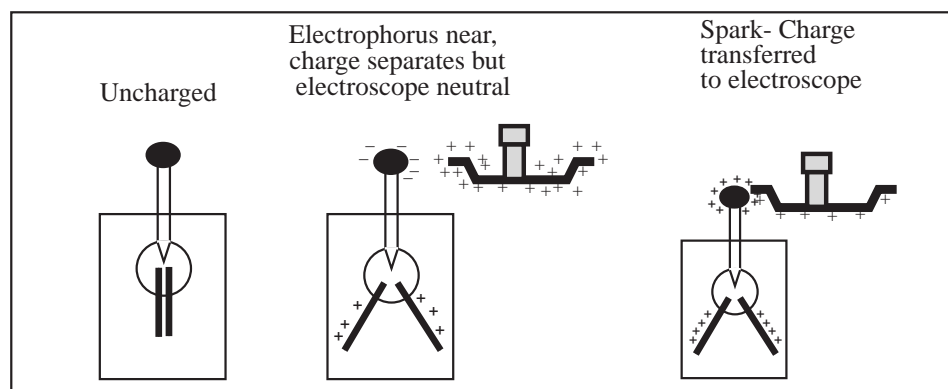

Detecting Charge with a Leaf Electroscope: The leaf electroscope detects charge in two ways. If a charged object is brought near the steel bolt, without transferring charge, then the electric force causes charge to separate in the electroscop, causing a deflection of the foils. The foils also deflect if a net charge is transferred to the electroscop.

3.2.2 Demonstrating Charge Separation with a Leaf Electroscope

After I built the electroscop, I charged up a golf tube and observed the following:

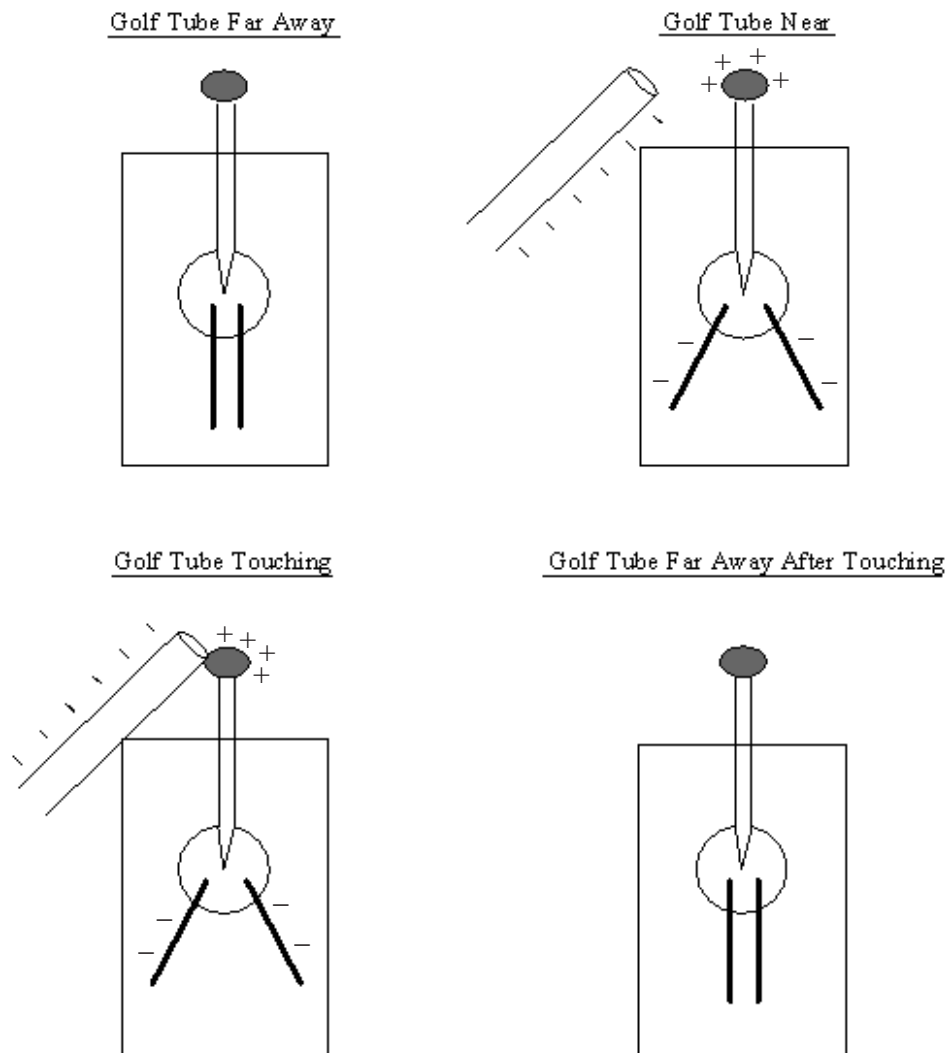

Charge separation happens when a charged object is brought near a conductor. Opposite charges are drawn closer to the charged object and like charges move farther away. This can be observed visually using a leaf electroscope. When a charged object, like the golf tube, is brought near the electroscop, but not so near that charge transfers, the leaves of the electroscop deflect indicating a net charge on the leaves. However, when the tube is removed the foils hang straight down indicating that no charge was transferred and the electroscop remained neutral throughout the process. What happened? The negatively charged tube attracted positive charge to the bolt of the electroscop, leaving a net negative charge behind in the leaves. This is charge separation. It turns out that since the tube is an insulator, there is no charge transfer even when the tube touches since charge cannot move through an insulator.

3.2.3 Charging a Leaf Electroscope by Induction

To charge a leaf electroscope or any conductor by induction, bring a charged object near the electroscope; but not so near that charge directly transfers. Ground the electroscope. While the external charged object is near, remove the connection to the ground. Remove the external charged object and the electroscope will have a net charge of opposite sign of the external charged object.

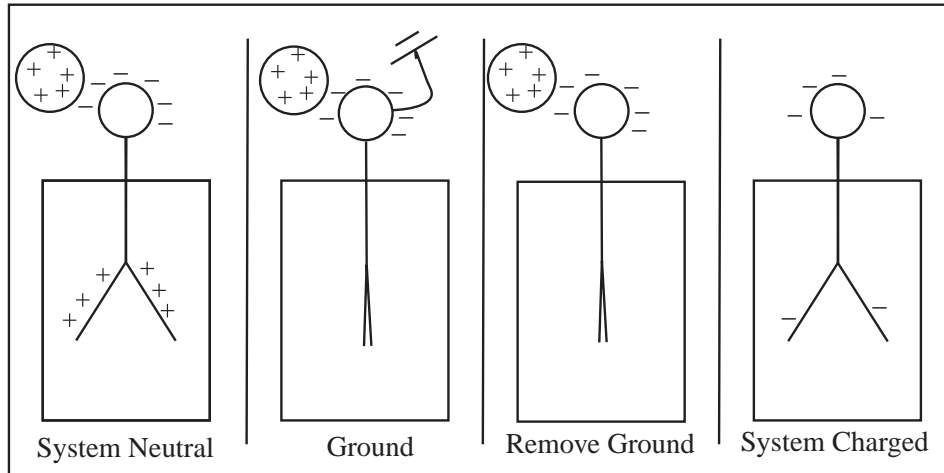

Now, let's return to the materials we worked with in lab and charge our leaf electroscope by induction. Charge up a golf tube producing a negatively charged object and bring the golf tube near the bolt of the electroscope. Charge separates in the electroscope and the leaves deflect. Touch the electroscope with your finger, thus grounding the scope. You are a much larger conductor than the scope and are a good ground for it. Remove your finger before the golf tube is removed and the electroscope will have a net positive charge.

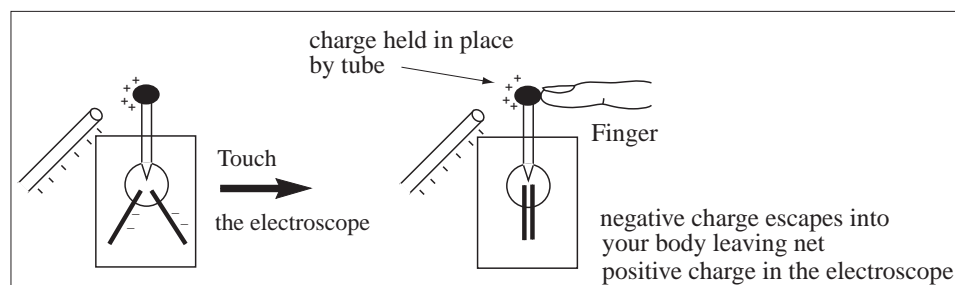

The order you do things in charging by induction is very important; if we touch the electroscope after the charged object is removed, the electroscope is grounded and has zero net charge.

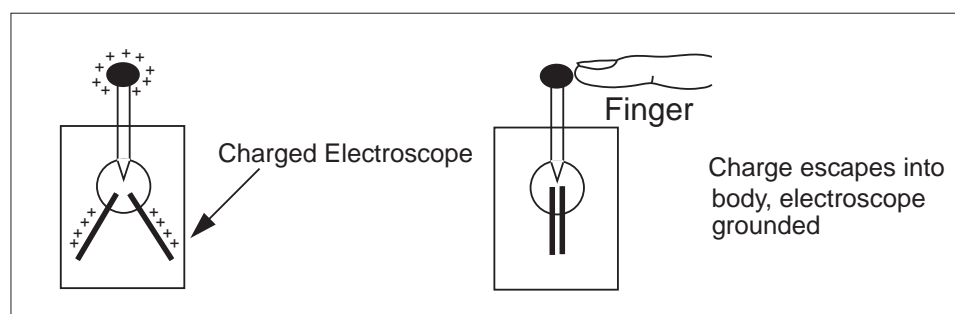

Example 3.2 Why Do Leaf Electroscope Leaves Un-Deflect?

Problem: In , the instructor charged a leaf electroscope by induction using a negatively charged golf tube. This gives the electroscope a net positive charge. A negatively charged golf tube was then brought close and the behavior observed. Draw the charged electroscope with the golf tube near and far away (2 diagrams). Physically, explain the behavior of the system in each drawing.

Solution

(a) Golf Tube Far Away: If the golf tube is far from the electroscope, the repulsion between the like charges causes the positive charges to spread out over the electroscope. The repulsive forces of the opposite charges on the leaves of the electroscope cause the leaf to deflect.

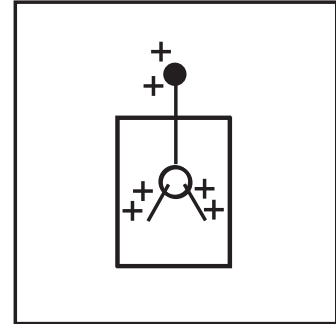

(b) Golf Tube Near: When the charged golf tube is brought near the charged electroscope, the net positive charges are brought into the bolt, leaving the leaves neutral, because opposite charges attract. The leaves are then uncharged and do not deflect.

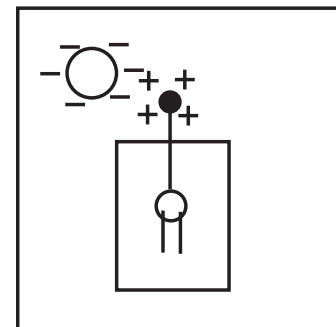

3.2.4 Demonstration of Capacity Using a Leaf Electroscope

I tried the following experiment with the leaf electroscope. I charged the electroscope, causing the leaves to deflect, and then I took a spool of insulated wire which was not connected to anything and touched the bolt. The leaves went mostly down. Even though it was connected to nothing, the spool of wire absorbed the charge because it was a larger “box” than the electroscope. I, then, disconnected the wire and grounded the electroscope. To see if the charge was really in the wire spool, I touched the electroscope with the end of the wire again. Sure enough the leaves moved slightly apart. The charge was in the wire spool.

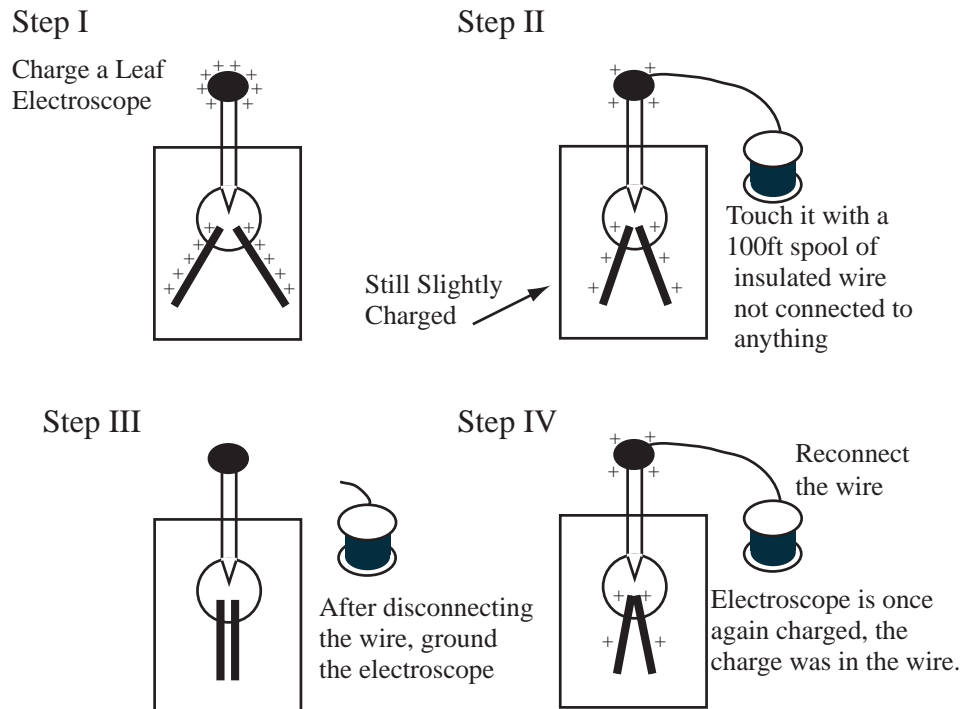

3.2.5 Demonstrating Positive and Negative Charge with a Leaf Electrostatic

We used the charged rods to show there are two different kinds of charge. We can use the leaf electroscope to show that when the two different kinds of charge are mixed, they cancel. This strongly implies the two kinds of charge may be thought of as $+$ and $-$ because they add like numbers. To demonstrate this, fill one electroscope with $+$ charge using the electrophorus and charge another electroscope negatively using charging by induction and the electrophorus. The foils of both electroscopes will be deflected. Now connect the electroscopes with a wire, the deflection of both scopes will decrease, with each electroscope sharing the sum of the electric charges. If the charges were equal and opposite, we would end up with two uncharged electroscopes.

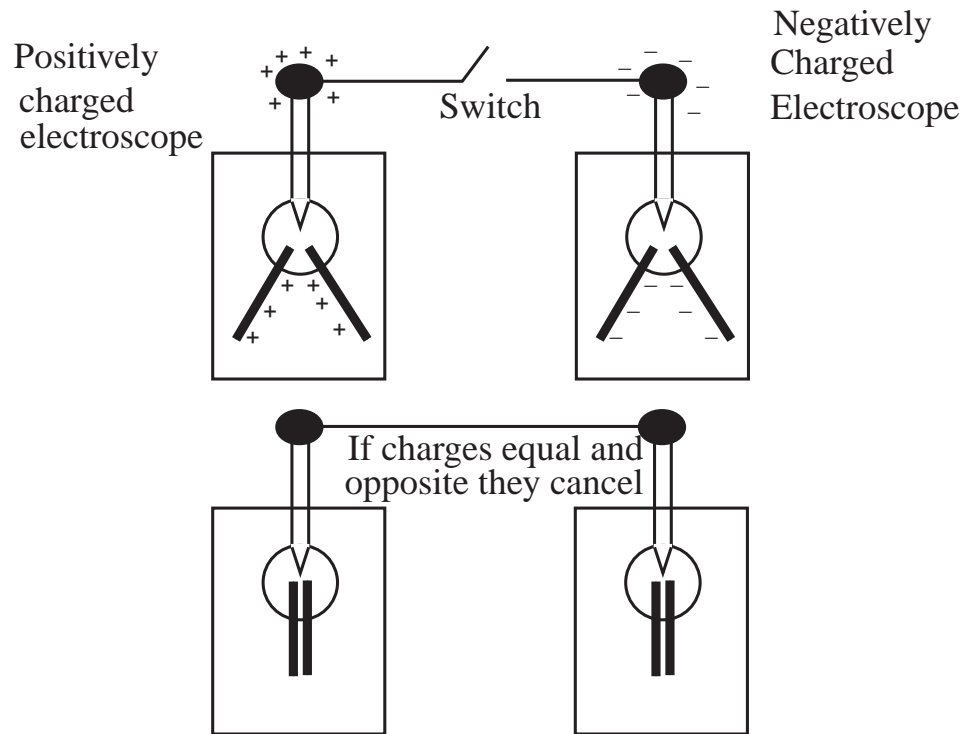

Example 3.3 Describing the Behavior of a Leaf Electroscope

Problem: I performed an experiment with two electroscopes connected by a wire. The results of the experiment are shown in the sequence of figures below. The following sequence of actions are represented in the figures:

- I Two neutral leaf electroscopes were connected by a conducting wire.
- II A charged rod was brought near the bolt of one of the electroscopes, while still far from the other electroscope. The leaves deflect as shown.
- III The wire between the electroscopes is cut, without loss of charge.
- IV The charged rod is removed.
- V The wire is reconnected.

No charge was transferred from the charged rod to the electroscope at any time. No charge is lost to the environment at any time. The wire allows the flow of charge but is sufficiently fine to contain none of the net charge. The electroscope far from the golf tube is sufficiently distant not to feel a force from the golf tube.

- (a) Draw the leaves on the electroscope in figure V.
- (b) Draw the location of all net charge on all figures. There is no net charge in figure I.
- (c) In general, in terms of general electrostatic principles, why do the leaves of a leaf electroscope deflect? (No more than two sentences).
- (d) What is the total charge of the two electroscopes in figure IV combined? (Positive, Negative, or Zero).
- (e) If the electroscopes in figure IV were close enough to interact, draw the direction of the force vector on each electroscope exerts on the other electroscope to scale.

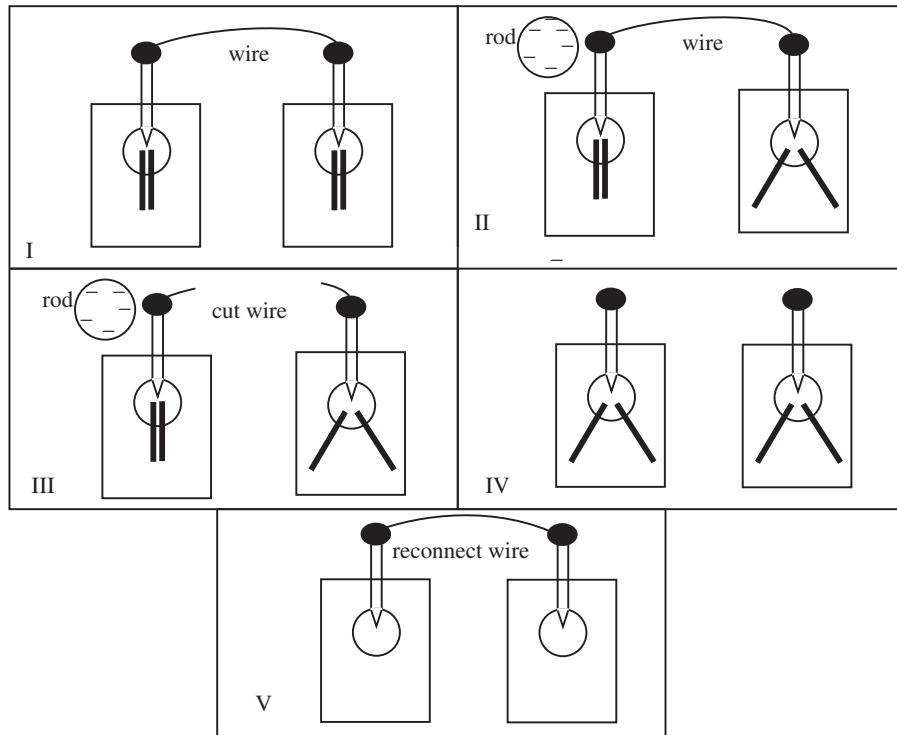

Solution to Part (a)

Both electrosopes become neutral because the total charge of the system is zero, by Conservation of Charge. So the leaves hang straight down as drawn.

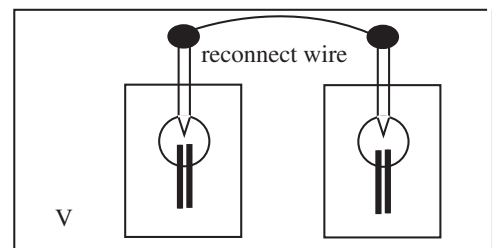

Solution to Part (b)

The charge is drawn in the figure below. The system of two electrosopes remains neutral so equal amounts of opposite and negative charge is drawn. Opposites attract so the electroscope nearer the tube is positive. No charge is in the leaves in figure III because they hang straight down. Charge spreads out throughout the electroscope in figure IV.

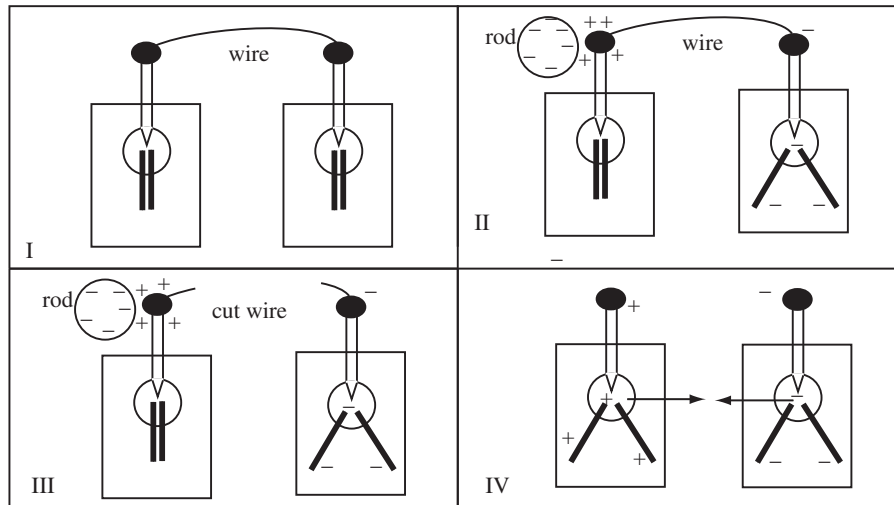

Solution to Part (c)

The leaves are filled with a net charge of the same sign. Like charges repel, causing the leaves to push apart.

Solution to Part (d)

Since no charge was transferred to the system and no charge was lost to the environment the total charge of the two scopes must be zero by conservation of charge.

Solution to Part (e)

The electrosopes have opposite charges so they attract each other with equal and opposite forces.

Chapter 4

Electric Force II

In the previous chapter, quite a bit of time was spent learning to reason about the effects of the electric force and the behavior of charge in materials. Now its time to crunch the numbers.

4.1 The Strength of the Electric Force

The physical law giving the force exerted on one point charge by another point charge is called *Coulomb's Law*. So far we have worked with electric force only qualitatively, no numbers have been computed. All we need to complete Coulomb's Law is to know the magnitude of the electric force. The magnitude of the electric force that an object with charge q_1 exerts on an object with charge q_2 is $F_e = \left| \frac{kq_1q_2}{d^2} \right|$ where d is the distance between the centers of the two objects. (This is assuming the objects are small compared with the distance between them. This is actually Coulomb's Law for point particles! Later we will see how to use this law to calculate electric force for things that cannot be assumed to be small.) With this addition, Coulomb's Law can be stated completely:

Coulomb's Law (Version 0): The force an object with charge q_1 exerts on an object with charge q_2 has the following properties:

- If the charges have opposite signs the force is attractive.
- If the charges have the same sign the force is repulsive.
- The direction of the electric force is along the line shared by the centers of the two charged objects.
- The magnitude of the electric force, F_e , is

$$F_e = \left| \frac{kq_1q_2}{d^2} \right|$$

where d is the distance between the centers of the two objects and $k = 8.99 \times 10^9 \frac{\text{Nm}^2}{\text{C}^2}$.

Example 4.1 Electric Force Exerted by Two Point Charges

Problem: Two +1C point charges are 1m apart. What is the magnitude of the force one exerts on the other?

Solution

The magnitude of the electric force is given by Coulomb's law

$$|F| = \frac{kq_1q_2}{r^2} = \frac{(8.99 \times 10^9 \frac{\text{Nm}^2}{\text{C}^2})(1\text{C})(1\text{C})}{(1\text{m})^2} = 8.99 \times 10^9 \text{N}$$

Example 4.2 Force Magnitude Only

Problem: Let object A have charge $q_A = 3\mu\text{C} = 3 \times 10^{-6}\text{C}$ and object B have charge $q_B = 2\mu\text{C}$. The locations of the charges are as drawn. Compute the electric force that object A exerts on object B. You may give the direction of the force in terms of the line between the charges.

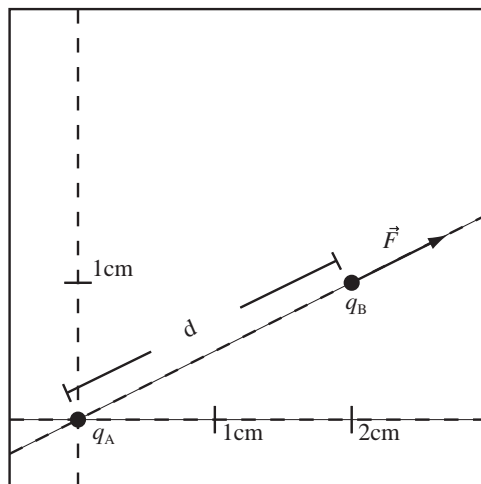

Solution

(a) Compute the Magnitude of Force: The direction of the electric force is outward along the line connecting the charges (Likes Repel). The magnitude of the force is $F_e = \left| \frac{kq_Aq_B}{d^2} \right|$ where d is the distance between the charges. Using the Pythagorean theorem for the charges drawn, $d^2 = (2\text{cm})^2 + (1\text{cm})^2 = 5\text{cm}^2 = 5 \times 10^{-4}\text{m}^2$, so

$$F_e = \left| \frac{(8.99 \times 10^9 \frac{\text{Nm}^2}{\text{C}^2})(3 \times 10^{-6}\text{C})(-2 \times 10^{-6}\text{C})}{5 \times 10^{-4}\text{m}^2} \right| = 108\text{N}$$

$$= 100\text{N with significant figures.}$$

(b) Write the Force as a Vector: Force is a vector, therefore both a magnitude and a direction must be reported.

$$\vec{F}_e = 100\text{N directed outward along the line connecting A \& B}$$

The above is a perfectly valid expression of the force, but it would be more useful if we could write it as:

$$\vec{F}_e = (F_x, F_y, F_z) \text{ or}$$

$$\vec{F}_e = F_x\hat{x} + F_y\hat{y} + F_z\hat{z} \text{ or}$$

$$\vec{F}_e = F_x\hat{i} + F_y\hat{j} + F_z\hat{k}$$

I called the above form of Coulomb's law "Version 0" because the vector form of the law which follows is the formulation that I think of as Coulomb's Law.

4.2 Review of Basic Vector Concepts

4.2.1 Vector Basics

A vector is a mathematical object with magnitude and direction. A vector is written with a small arrow over the symbol. A vector is perfectly well specified by telling how long it is and in which direction it points. For example, the vector \vec{A} might be specified as $\vec{A} = 5\text{yaks}$ to the North. The vector \vec{A} then has magnitude $|\vec{A}| = A = 5\text{yaks}$ and direction to the North. Students like to write unusual vector expressions where a vector equals a quantity that is not a vector. This is not allowed and will result in points being taken off on a test. The following is a list of vector definitions which will be used extensively in this class.

Writing a Vector in its Coordinate Form: A vector may be written by giving its length along each of the axes of a coordinate system. Each of the following are equivalent.

$$\vec{F} = (F_x, F_y, F_z) = F_x\hat{x} + F_y\hat{y} + F_z\hat{z} = F_x\hat{i} + F_y\hat{j} + F_z\hat{k}$$

Definition of Coordinate Unit Vectors: $\hat{i} = \hat{x}$, $\hat{j} = \hat{y}$, and $\hat{k} = \hat{z}$ are vectors with length one that point along the coordinate axis. You can use either \hat{i} , \hat{j} , \hat{k} or \hat{x} , \hat{y} , \hat{z} , but don't mix them in the same problem.

Vector Addition: The sum of two vectors is found by adding their components

$$\vec{F}_R = \vec{F}_1 + \vec{F}_2 = (F_{1x}, F_{1y}, F_{1z}) + (F_{2x}, F_{2y}, F_{2z}) = (F_{1x} + F_{2x})\hat{i} + (F_{1y} + F_{2y})\hat{j} + (F_{1z} + F_{2z})\hat{k}$$

Multiplication of Vector by Number: A vector can be multiplied by a number, c , to yield a vector c times longer but in the same direction. In coordinate form,

$$c\vec{F} = (cF_x, cF_y, cF_z)$$

Vectors are graphically represented as arrows and addition and subtraction of vectors can be done graphically.

Adding Vectors Graphically: Two vectors \vec{F}_1 and \vec{F}_2 , for example two forces on charge q , can be added graphically to form a resultant or total vector $\vec{F}_T = \vec{F}_1 + \vec{F}_2$ by placing the tail of the second vector on the point of the first vector. The resultant vector is drawn from the tail of the first vector to the point of the second vector. The second vector is drawn as a dashed line.

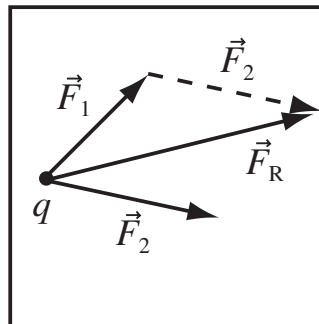

Subtracting Vectors Graphically: Two vectors, \vec{r}_1 and \vec{r}_2 , may be subtracted graphically, for example to form the displacement $\vec{r}_{12} = \vec{r}_2 - \vec{r}_1$. This is done by adding $(-\vec{r}_1)$ and \vec{r}_2 . The negative of a vector is the same vector pointing in the opposite direction.

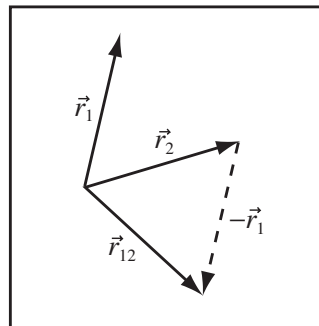

4.2.2 Manipulating Vectors, Unit Vectors, and Magnitudes

A vector has magnitude and direction. The most important operation we will do with vectors is to take a vector's coordinate form and extract the magnitude and direction. The magnitude or length of a vector, \vec{A} , is written $|\vec{A}|$ or just A . The direction of a vector is represented by the unit vector \hat{A} . The extraction of both the magnitude and the direction of a vector is shown below.

Definition of Vector Modulus: The modulus (magnitude) or length of a vector, \vec{v} , is

$$v = |\vec{v}| = \sqrt{v_x^2 + v_y^2 + v_z^2}.$$

Definition of Unit Vector: A unit vector is a vector of length one. Given a vector \vec{r} , whose modulus is $|\vec{r}|$, the unit vector is

$$\hat{r} = \frac{\vec{r}}{|\vec{r}|} = \frac{r_x}{|\vec{r}|}\hat{x} + \frac{r_y}{|\vec{r}|}\hat{y} + \frac{r_z}{|\vec{r}|}\hat{z}.$$

The unit vector is a vector of length 1 with the same direction as the vector.

Writing Vector as Magnitude and Unit Vector: A vector \vec{v} can be written as its magnitude $|\vec{v}| = v = \sqrt{v_x^2 + v_y^2 + v_z^2}$ multiplied by a unit vector, $\hat{v} = \vec{v}/|\vec{v}|$, in its direction,

$$\vec{v} = |\vec{v}|\hat{v}.$$

4.2.3 Position and Displacement Vectors

The electric and magnetic force depend on the distance and direction from the point where the charge exists to the point where the force is exerted, therefore the vector representing this directed distance is the one we find ourselves computing most often. This vector is called the *displacement vector* and its length is the distance between the two points.

Definition of Position Vector: A position vector points from the origin to a point. A position vector for point A is written as \vec{r}_A . The coordinate form of a position vector is just the coordinates of the point. For example, if the point C is at $(0, 3\text{m}, 0)$ then the coordinate form of the position vector $\vec{r}_C = (0, 3\text{m}, 0)$.

Definition of Displacement Vector: A displacement vector points from one point to another. A displacement vector from point A to point B is written as \vec{r}_{AB} . Note the order of the subscripts. The displacement vector can be calculated by subtracting the two position vectors: $\vec{r}_{AB} = \vec{r}_B - \vec{r}_A$.

Distance Between Two Points: The distance between two points given by position vectors $\vec{r}_1 = (x_1, y_1, z_1)$, and $\vec{r}_2 = (x_2, y_2, z_2)$ is the magnitude of the displacement vector $\vec{r}_{12} = \vec{r}_2 - \vec{r}_1$, of the vector pointing from point 1 to point 2,

$$\text{Distance} = |\vec{r}_{12}| = \sqrt{(x_2 - x_1)^2 + (y_2 - y_1)^2 + (z_2 - z_1)^2}.$$

Example 4.3 Manipulating Displacement Vectors

Problem: Point 1 is at $(1\text{cm}, 3\text{cm}, 5\text{cm})$ and Point 2 is at $(3\text{cm}, 3\text{cm}, 0)$.

- Compute \vec{r}_{12} .
- Compute $|\vec{r}_{12}|$.
- Compute \hat{r}_{12} .

Solution to Part(a)

The displacement vector, \vec{r}_{12} , is a vector which points from point 1 to point 2,

$$\begin{aligned}\vec{r}_{12} &= \vec{r}_2 - \vec{r}_1 = (3\text{cm} - 1\text{cm}, 3\text{cm} - 3\text{cm}, 0 - 5\text{cm}) \\ &= (2\text{cm})\hat{x} + 0\hat{y} - (5\text{cm})\hat{z}\end{aligned}$$

Solution to Part(b)

The modulus or length of a vector is by definition

$$\begin{aligned}|\vec{r}_{12}| &= r_{12} = \sqrt{r_{12x}^2 + r_{12y}^2 + r_{12z}^2} \\ |\vec{r}_{12}| &= \sqrt{(2\text{cm})^2 + 0^2 + (-5\text{cm})^2} \\ r_{12} &= \sqrt{29}\text{cm}\end{aligned}$$

Solution to Part(c)

The vector \hat{r}_{12} is a unit vector (a vector of length one) in the direction of the vector \vec{r}_{12} . The unit vector is found by dividing \vec{r}_{12} by its length r_{12} .

$$\hat{r}_{12} = \frac{\vec{r}_{12}}{r_{12}} = \frac{2}{\sqrt{29}}\hat{x} - \frac{5}{\sqrt{29}}\hat{z}$$

A key step to visualizing and simplifying the calculation of the electric force of a system of point charges is correctly drawing a diagram.

Use Opposites Attract/Likes Repel to Get Direction: Use opposites attract/like repel and the fact that force acts along the line between the charges to get the direction of forces correct. In the diagram below, q and q_1 have the same sign so the force on q points away from q_1 (Likes Repel). q and q_2 have different signs, so the force on q points toward q_2 (Opposites Attract).

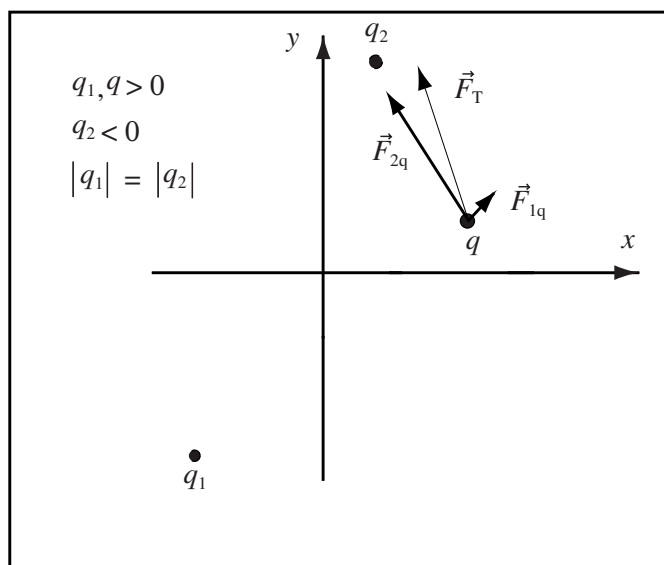

Use reasoning to get approximate relative magnitudes: If charges have sizes or distances that are easily comparable use the fact that the magnitude of the Force increases linearly with charge and decreases quadratically with distance. In the figure above, $|q_1| = |q_2|$ so the difference in magnitude is due to the difference in distances to q . The electric force decays as $1/r^2$, so since the distance q_1 to q is about twice q_2 to q , $|\vec{F}_{2q}|$ is four times $|\vec{F}_{1q}|$.

Compute Total or Resultant Force: The total force on an object, also called the net or resultant force, is found by adding all the forces applied to the object.

4.3 Coulomb's Law

Now it's time to let vectors work for us. All of Coulomb's Law can be encoded into a single equation.

Coulomb's Law (Vector Form): The electric force object A with charge q_A exerts on object B with charge q_B is given by

$$\vec{F}_{AB} = \frac{kq_Aq_B}{r_{AB}^2}\hat{r}_{AB}$$

where \vec{r}_{AB} is a vector which points from the location of object A to the location of object B and $k = 8.99 \times 10^9 \frac{\text{Nm}^2}{\text{C}^2}$.

To successfully use the vector form of Coulomb's Law, we need to be able to manipulate the related quantities \vec{r}_{AB} , r_{AB} , and \hat{r}_{AB} . I will restate their definitions for Coulomb's law.

The Position Vector: The position vector, \vec{r}_A , for point A located at the coordinates (A_x, A_y, A_z) is a vector from the origin to the point A , $\vec{r}_A = A_x\hat{x} + A_y\hat{y} + A_z\hat{z}$. The components of the position vector will be denoted by $r_{Ax} = A_x$, $r_{Ay} = A_y$, and $r_{Az} = A_z$.

The Displacement Vector: The vector \vec{r}_{AB} points FROM point A TO point B and has the length of the distance between the points. The displacement vector can be computed as the difference of the position vectors

$$\vec{r}_{AB} = \vec{r}_B - \vec{r}_A = (r_{Bx} - r_{Ax}, r_{By} - r_{Ay}, r_{Bz} - r_{Az}).$$

Modulus of the Displacement Vector: The length of the vector \vec{r}_{AB} will be denoted by r_{AB} and is the distance from point A to point B. It can be computed in the same way as the length of any vector

$$r_{AB} = |\vec{r}_{AB}| = \sqrt{r_{ABx}^2 + r_{ABy}^2 + r_{ABz}^2},$$

where the symbol $|\vec{V}|$ represents the mathematical operation of taking the length of a vector, called the *vector modulus*.

Unit Vector for the Displacement Vector: The vector \hat{r}_{AB} is a vector with length 1 (no units) pointing from point A to point B. It can be computed using

$$\hat{r}_{AB} = \frac{\vec{r}_{AB}}{r_{AB}} = \left(\frac{r_{ABx}}{r_{AB}}, \frac{r_{ABy}}{r_{AB}}, \frac{r_{ABz}}{r_{AB}} \right)$$

Let's return to the calculation of the force charge A exerts on charge B and do it using vectors.

Example 4.4 Computing Electric Force Using Vectors

Problem: Let object A have charge $q_A = 3\mu\text{C} = 3 \times 10^{-6}\text{C}$ and object B have charge $q_B = 2\mu\text{C}$. The locations of the charges are as drawn. Compute the force object A exerts on object B.

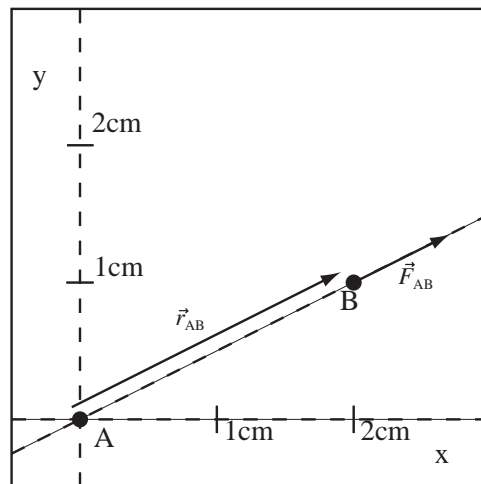

Solution

(a) **Use Coulomb's Law:** The electric force object A with charge q_A exerts on object B with charge q_B is

$$\vec{F}_{AB} = \frac{kq_Aq_B}{r_{AB}^2}\hat{r}_{AB}$$

(b) Compute the Displacement Vector: The displacement vector points from the location of A to the location of B ,

$$\vec{r}_{AB} = (2\text{cm}, 1\text{cm}, 0) = \vec{r}_B - \vec{r}_A.$$

which is consistent with the drawing since we have to move $+2\text{cm}$ in the x direction and $+1\text{cm}$ in the y direction to move from A to B .

(c) Compute the Length of the Displacement Vector: The length of the displacement vector is by definition of vector modulus

$$r_{AB} = |\vec{r}_{AB}| = \sqrt{r_{ABx}^2 + r_{ABy}^2 + r_{ABz}^2} = \sqrt{(2\text{cm})^2 + (1\text{cm})^2 + 0^2} = \sqrt{5}\text{cm}.$$

This had better equal the distance between points calculated earlier.

(d) Compute the Unit Vector: The unit vector for the displacement vector is by definition

$$\hat{r}_{AB} = \frac{\vec{r}_{AB}}{r_{AB}}$$

$$\begin{aligned}\hat{r}_{AB} &= \frac{\vec{r}_{AB}}{r_{AB}} = \frac{1}{\sqrt{5}\text{cm}}(2\text{cm}, 1\text{cm}, 0) \\ &= \left(\frac{2}{\sqrt{5}}, \frac{1}{\sqrt{5}}, 0\right)\end{aligned}$$

The unit vector \hat{r}_{AB} should end up dimensionless, which it did. It also had better have length 1

$$\begin{aligned}|\hat{r}_{AB}| &= \sqrt{\hat{r}_{ABx}^2 + \hat{r}_{ABy}^2 + \hat{r}_{ABz}^2} \\ &= \sqrt{\left(\frac{2}{\sqrt{5}}\right)^2 + \left(\frac{1}{\sqrt{5}}\right)^2 + 0} \\ &= \sqrt{\frac{5}{5}} = 1\end{aligned}$$

(e) Substitute into Coulomb's Law: Substitute the vectors computed above into Coulomb's Law and turn the crank, being careful to convert cm properly, $(\sqrt{5}\text{cm})^2 = 5\text{cm}^2 = 5 \times 10^{-4}\text{m}^2$,

$$\begin{aligned}\vec{F}_{AB} &= \frac{kq_Aq_B}{r_{AB}^2}\hat{r}_{AB}. \\ \vec{F}_{AB} &= \left(\frac{(8.99 \times 10^9 \frac{\text{Nm}^2}{\text{C}^2})(3 \times 10^{-6}\text{C})(2 \times 10^{-6}\text{C})}{5 \times 10^{-4}\text{m}^2}\right)\left(\frac{2}{\sqrt{5}}, \frac{1}{\sqrt{5}}, 0\right) \\ \vec{F}_{AB} &= 100\text{N}\left(\frac{2}{\sqrt{5}}, \frac{1}{\sqrt{5}}, 0\right) \\ \vec{F}_{AB} &= (89\text{N}, 45\text{N}, 0)\end{aligned}$$

The previous example placed one of the charges at the origin. The next example has both charges away from the origin.

Example 4.5 Force on one point charge due to another

Problem: A point charge $q_B = 1.0\mu\text{C}$ at $\vec{r}_B = (0.50\text{cm}, 1.45\text{cm}, 0)$ feels the electric force from a charge $q_A = -1.0\mu\text{C}$ at $\vec{r}_A = (1.4\text{cm}, 0.70\text{cm}, 0)$. Compute the force of q_A on q_B , \vec{F}_{AB} .

Solution

Definitions

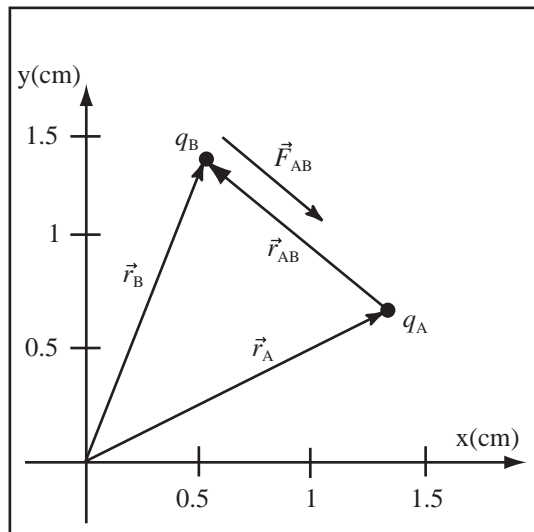

$$q_B = 1.0\mu\text{C} \equiv \text{Charge of } q_B$$

$$q_A = -1.0\mu\text{C} \equiv \text{Charge of } q_A$$

$$\vec{r}_B = (0.50\text{cm}, 1.45\text{cm}, 0) \equiv \text{Position of } q_B$$

$$\vec{r}_A = (1.4\text{cm}, 0.70\text{cm}, 0) \equiv \text{Position of } q_A$$

$$\vec{r}_{AB} \equiv \text{Vector from } q_A \text{ to } q_B$$

$$\vec{F}_{AB} \equiv \text{Force on } q_B \text{ due to } q_A$$

Strategy: Calculate the force between two point charges using Coulomb's Law; this requires calculating the position vector in both magnitude and direction.

(a) **Draw a Good Diagram:** The charges are placed at the given locations. Since unlike charges attract, the force exerted by q_A on q_B is attractive.

(b) **Use Coulomb's Law:** The force on q_B from q_A is given by: $\vec{F}_{AB} = \frac{kq_A q_B}{r_{AB}^2} \hat{r}_{AB}$

(c) **Use Definition of Displacement Vector:** The displacement vector is a vector that points from the location of charge A to the location of charge B .

$$\begin{aligned} \vec{r}_{AB} &= \vec{r}_B - \vec{r}_A = (r_{Bx} - r_{Ax}, r_{By} - r_{Ay}, r_{Bz} - r_{Az}) = (0.50\text{cm} - 1.4\text{cm}, 1.45\text{cm} - 0.70\text{cm}, 0 - 0) = (-0.90\text{cm}, 0.75\text{cm}, 0) \\ &= (-0.90\text{cm}, 0.75\text{cm}, 0) \end{aligned}$$

(d) **Use Definition of Vector Modulus:** Calculate the length of the displacement vector,

$$r_{AB} = \sqrt{r_{ABx}^2 + r_{ABy}^2 + r_{ABz}^2} = \sqrt{(-0.90\text{cm})^2 + (0.75\text{cm})^2 + (0)^2} = 1.2\text{cm}$$

(e) **Use Definition of Unit Vector:**

$$\hat{r}_{AB} = \frac{\vec{r}_{AB}}{r_{AB}} = \frac{(-0.90\text{cm}, 0.75\text{cm}, 0)}{1.2\text{cm}} = (-0.75, 0.63, 0)$$

(f) **Substitute into Coulomb's Law:**

$$\begin{aligned} \vec{F}_{AB} &= \frac{kq_A q_B}{r_{AB}^2} \hat{r}_{AB} \\ &= \frac{(8.99 \times 10^9 \frac{\text{Nm}^2}{\text{C}^2})(1.0 \times 10^{-6}\text{C})(-1.0 \times 10^{-6}\text{C})}{(1.2 \times 10^{-2}\text{m})^2} \cdot (-0.75, 0.63, 0) \end{aligned}$$

$$\vec{F}_{AB} = -62\text{N} \cdot (-0.75, 0.63, 0) = (47\text{N}, -39\text{N}, 0)$$

(g) **Check:** Make sure the direction calculated matches the diagram.

4.3.1 Qualitative Features of Coulomb's Law

We spent a lot of time in Course Guide 2 and Course Guide 3 developing a feeling for the electric force. It is somewhat amazing that all the features we discovered are captured by $\vec{F}_{12} = (kq_1 q_2 / r_{12}^2) \hat{r}_{12}$. The next example investigates how the qualitative features of the electric force are represented in Coulomb's Law.

Example 4.6 How Qualitative Features of the Electric Force are Represented in Coulomb's Law?

Problem: Coulomb's Force Law relates the force object 1 exerts on object 2, to the charges of the objects and the distance r_{12} between the objects:

$$\vec{F}_{12} = \frac{kq_1q_2}{r_{12}^2}\hat{r}_{12}$$

where k is a constant and \hat{r}_{12} is a unit vector in the direction of the vector \vec{r}_{12} which points from the center of object 1 to the center of object 2. This equation contains a lot of information. Let's explore.

- Draw two objects with charge q_1 and q_2 , the vector \vec{r}_{12} and \hat{r}_{12} . \hat{r}_{12} is a vector of length 1 (but no dimensions) in the same direction as \vec{r}_{12} .
- What part of Coulomb's Law represents the law "The magnitude of the electric force decreases with the square of the distance between the charges?"
- What part of Coulomb's Law represents the law, "The electric force between two objects is directly proportional to the charge of either object"
- What part of Coulomb's Law represents the law, "The electric force is directed along the line between the charges"
- What part of Coulomb's Law represents the law "Opposite charges attract, like charges repel"

Solution to Part (a)

The vector \vec{r}_{12} points from the center of object 1 to the center of object 2. The unit vector \hat{r}_{12} is a vector of unit length, but no dimensions, in the same direction. Since \vec{r}_{12} is measured in meters and \hat{r}_{12} has no dimensions their lengths have no relation in the diagram.

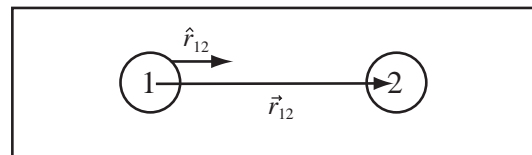

Solution to Part (b)

The distance dependence of the electric force is represented in Coulomb's Force Law by the terms $F \propto \frac{1}{r_{12}^2}$ where the magnitude of the force decreases with increasing distance.

Solution to Part (c)

Since $F_{12} \propto q_1q_2$, the electric force is proportional to the magnitude of either charge.

Solution to Part (d)

The unit vector \hat{r}_{12} points along a line from q_1 to q_2 . The direction of the force is either $\pm\hat{r}_{12}$.

Solution to Part (e)

The force is repulsive if \vec{F}_{12} points in the direction \hat{r}_{12} and attractive if it points in the direction $-\hat{r}_{12}$. Both $k > 0$ and $r_{12}^2 > 0$, so the direction of the force is given by $q_1q_2\hat{r}_{12}$. If both charges have the same sign $q_1q_2 > 0$ and $q_1q_2\hat{r}_{12}$ points in the direction of \hat{r}_{12} so the force is repulsive. If q_1 and q_2 have different signs $q_1q_2 < 0$, then $q_1q_2\hat{r}_{12}$ points in the $-\hat{r}_{12}$ direction and the force is attractive.

People have a very hard time accepting Newton's Third Law; that for any pair of objects the force object 1 exerts on object 2 is equal and opposite to the force object 2 exerts on object 1. The next example explores Newton's Third Law and the electric force.

Example 4.7 Prove Newton's Third Law for Electric Force

Problem: Consider two objects, 1 and 2, which have charges $Q_1 = Q$ and $Q_2 = 5Q$ where $Q = +1\mu\text{C}$. The charges are at $\vec{r}_1 = (0, 0, 0)$ and $\vec{r}_2 = (10\text{cm}, 0, 0)$.

(a) Compute \vec{F}_{12} and \vec{F}_{21} .

(b) Show that Newton's Third Law holds for any two objects with charges q_A and q_B , that is show $\vec{F}_{AB} = -\vec{F}_{BA}$.

Solution to Part (a)

(a) Draw Diagram: By likes repel, the forces are as drawn. By observation, $\vec{r}_{12} = (10\text{cm}, 0, 0)$ and $\vec{r}_{21} = (-10\text{cm}, 0, 0)$. By definition, \vec{r}_{12} points from Q_1 to Q_2 .

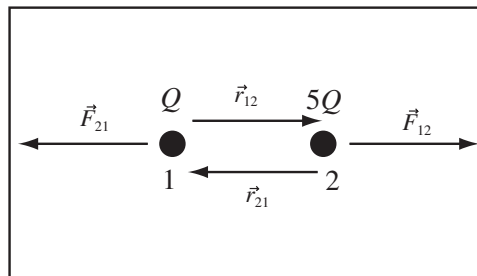

(b) Compute \vec{F}_{12} : Using Coulomb's Force Law and $\hat{r}_{12} = \hat{x}$, $r_{12} = 10\text{cm}$,

$$\vec{F}_{12} = \frac{kQ_1Q_2}{r_{12}^2}\hat{r}_{12} = \frac{kQ_1Q_2}{r_{12}^2}\hat{x}$$

$$\vec{F}_{12} = \frac{(9 \times 10^9 \frac{\text{Nm}^2}{\text{C}^2})(1\mu\text{C})(5\mu\text{C})}{(10\text{cm})^2}\hat{x} = 4.5 \times 10^{-2}\text{N}(\hat{x})$$

(c) Compute \vec{F}_{21} : Using Coulomb's Law and $r_{21} = 10\text{cm}$ and $\hat{r}_{21} = -\hat{x}$,

$$\vec{F}_{21} = \frac{kQ_2Q_1}{r_{21}^2}\hat{r}_{21} = -\frac{kQ_1Q_2}{r_{21}^2}\hat{x} = -4.5 \times 10^{-2}\text{N}(\hat{x})$$

$$\vec{F}_{21} = -\vec{F}_{12}$$

Solution to Part (b)

Let \vec{r}_{AB} be the vector from the object with charge q_A to the object with q_B . The vector from B to A is then $\vec{r}_{BA} = -\vec{r}_{AB}$. The distance from A to B equals the distance from B to A , so $|\vec{r}| = r_{BA} = r_{AB}$. The unit vectors are related by

$$\hat{r}_{AB} = \frac{\vec{r}_{AB}}{|\vec{r}_{AB}|} = \frac{-\vec{r}_{BA}}{|\vec{r}_{BA}|} = -\hat{r}_{BA}.$$

So substituting into Coulomb's Force Law,

$$\vec{F}_{AB} = \frac{kq_Aq_b}{r_{AB}^2}\hat{r}_{AB} = \frac{kq_Bq_A}{r_{BA}^2}(-\hat{r}_{BA}) = -\vec{F}_{BA}.$$

Chapter 5

Electric Field

We directly compute the electric force for only a few point charges. We will find it much more powerful in most cases to compute the electric field.

5.1 Definition of Electric Field

For the rest of the class, we will be primarily interested in charge and field. Forces will be of secondary importance, something that it is easy to calculate after the real work is done. The first field we encounter is the *electric field*. Consider the following situation: a set of point charges, q_i , are scattered all over the place at points \vec{r}_i , as shown to the right. We are then asked to compute the electric force on a charge q_A placed at point P . Using the vector form of Coulomb's Law, we find the net force on q_A is

$$\vec{F}_A = \sum_{i=1}^5 \frac{kq_A q_i}{r_{iP}^2} \hat{r}_{iP}$$

Now, if we were asked to compute the force on a different charge placed at point P , q_B , we would compute

$$\vec{F}_B = \sum_{i=1}^5 \frac{kq_B q_i}{r_{iP}^2} \hat{r}_{iP}.$$

If I gave you enough of these charges at point P , you would start computing

$$\vec{F}_A = q_A \left(\sum_{i=1}^5 \frac{kq_i}{r_{iP}^2} \hat{r}_{iP} \right)$$

where you only have to compute the quantity inside the parentheses, $\left(\sum_{i=1}^5 \frac{kq_i}{r_{iP}^2} \hat{r}_{iP} \right)$, once for each point P .

Simply multiplying the charge of any object placed at the point P by this quantity gives the force that the object *WOULD* feel if it was placed at the point. Let's divide by q_A and separate this thing out, giving it the symbol \vec{E} ,

$$\vec{E}_P = \frac{\vec{F}_A}{q_A} = \sum_{i=1}^5 \frac{kq_i}{r_{iP}^2} \hat{r}_{iP}.$$

Note, I wrote \vec{E}_P and not \vec{E}_A because \vec{E} is a property of the charges q_i and the point P . It has nothing to do with the charge q_A placed at point P . As my Texan father-in-law would say, "Now we're cooking with gas!"

Definition of Electric Field: The electric field \vec{E} at a point \vec{r} is defined as the electric force \vec{F} a charge q_0 would experience if placed at \vec{r} , divided by q_0 , $\vec{E} = \vec{F}/q_0$.

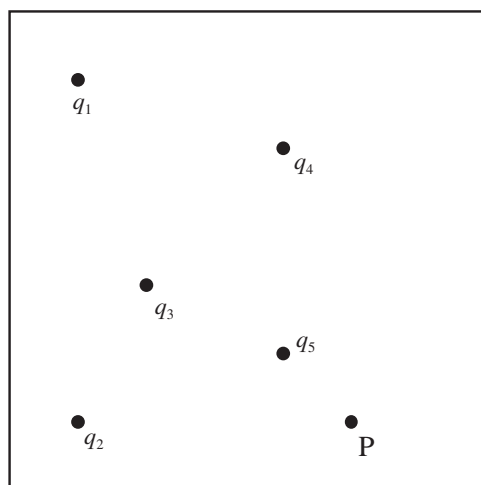

Electric field is force per unit charge:

Units of Electric Field: The electric field is measured in Newtons per Coulomb, N/C.

Sizes of Electric Fields: Air sparks at an electric field of $3 \times 10^6 \frac{\text{N}}{\text{C}}$. The golf tube creates a field of $1 \times 10^6 \frac{\text{N}}{\text{C}}$ at its surface, the pith ball creates a field of $1 \times 10^3 \frac{\text{N}}{\text{C}}$ at 2cm. The earth's electric field, which none of us ever notice, is $150 \frac{\text{N}}{\text{C}}$.

There are two main things to take away from this section. First, if you have calculated the field, all you have to do to calculate the force on an object with charge q is multiple by the field.

Calculate the Electric Force from the Electric Field: By definition of electric field, the electric force on an object with charge q placed at point P is the electric field, \vec{E}_P , at point P multiplied by the charge

$$\vec{F} = q\vec{E}_P$$

The second main point is that you can figure out the direction of the field, if you can figure out the direction of the force a positive charge WOULD feel if placed in the field. This observation is extremely useful because you should be quite good at using opposites attract/likes repel to figure out the direction of the electric force.

Direction of the Electric Field: The electric field at a point P points in the direction of the electric force a positive point charge WOULD feel if placed at point P .

5.2 Coulomb's Law for Electric Field

5.2.1 Coulomb's Law for the Electric Field

The only thing for which we know how to calculate the electric force is a point charge. In , Coulomb's law gave the force an object with charge q_1 exerts on an object with charge q_2 as

$$\vec{F}_{12} = \frac{kq_1q_2}{r_{12}^2} \hat{r}_{12}$$

Applying the definition of electric field, $\vec{E}_{12} = \frac{\vec{F}_{12}}{q_2}$, we derive Coulomb's law for the electric field.

Coulomb's Law for the Electric Field: A point charge produces an electric field that points radially outward from or inward to the charge. The electric field, \vec{E}_{10} , produced by object 1 with charge q_1 at point 0 is given by:

$$\vec{E}_{10} = \frac{kq_1}{r_{10}^2} \hat{r}_{10},$$

where $k = 8.99 \times 10^9 \text{Nm}^2/\text{C}^2$, and \vec{r}_{10} is the vector which points from the location of object 1 to the point 0 where the field is measured.

Example 5.1 Electric Field of a Point Charge

Problem: A point charge with magnitude $q = 8\text{nC}$ is at point 1 at (1cm, -1cm, 1cm). Consider the electric field at a point P (3cm, 0, 0).

- Write the displacement vector
- What is the length of the displacement vector?
- Write a unit vector in the direction of the displacement vector.
- Compute the electric field at point P .

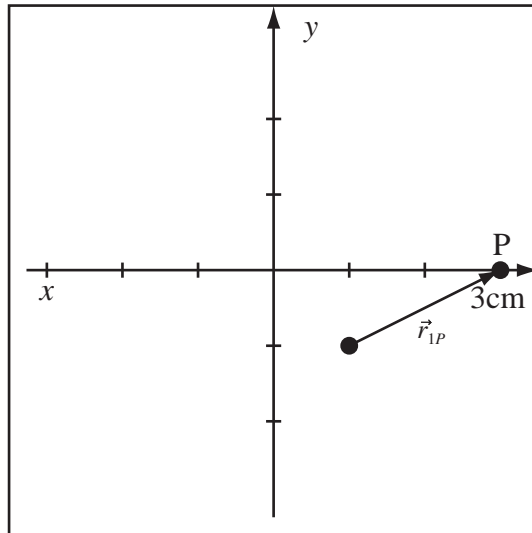
Definitions $\vec{r}_{1P} \equiv$ Displacement Vector $Q = 8\text{nC} \equiv$ Electric Charge $\vec{E}_{1P} \equiv$ Electric Field at Point P **Solution to Part (a)**

The displacement vector is, by definition,

$$\vec{r}_{1P} = \vec{r}_P - \vec{r}_1 = (3\text{cm}, 0, 0) - (1\text{cm}, -1\text{cm}, 1\text{cm})$$

$$\vec{r}_{1P} = (2\text{cm}, 1\text{cm}, -1\text{cm})$$

Solution to Part (b)

The length of the displacement vector is, by the definition of vector modulus,

$$r_{1P} = \sqrt{(2\text{cm})^2 + (1\text{cm})^2 + (-1\text{cm})^2}$$

$$r_{1P} = \sqrt{6}\text{cm}$$

Solution to Part (c)

The unit vector for \vec{r}_{1P} is, by definition,

$$\hat{r}_{1P} = \frac{\vec{r}_{1P}}{r_{1P}} = \frac{(2\text{cm}, 1\text{cm}, -1\text{cm})}{\sqrt{6}\text{cm}}$$

$$\hat{r}_{1P} = \left(\frac{2}{\sqrt{6}}, \frac{1}{\sqrt{6}}, \frac{-1}{\sqrt{6}} \right)$$

Solution to Part (d)

The electric field of a point charge is given by Coulomb's Law,

$$\begin{aligned} \vec{E}_P &= \frac{kQ}{r_{1P}^2} \hat{r}_{1P} \\ &= \frac{(8.99 \times 10^9 \frac{\text{Nm}^2}{\text{C}^2})(8 \times 10^{-9}\text{C})}{(\sqrt{6} \times 10^{-2}\text{m})^2} \left(\frac{2}{\sqrt{6}}, \frac{1}{\sqrt{6}}, \frac{-1}{\sqrt{6}} \right) \end{aligned}$$

$$\vec{E}_P = (1.2 \times 10^5 \frac{\text{N}}{\text{C}}) \left(\frac{2}{\sqrt{6}}, \frac{1}{\sqrt{6}}, \frac{-1}{\sqrt{6}} \right)$$

-OR-

$$\vec{E}_P = \left(9.8 \times 10^4 \frac{\text{N}}{\text{C}}, 4.9 \times 10^4 \frac{\text{N}}{\text{C}}, -4.9 \times 10^4 \frac{\text{N}}{\text{C}} \right)$$

5.2.2 Fields of More than One Point Charge

Almost any charged object has more than one point charge. The total field at point P can be calculated if the fields of the individual charges are known.

Law of Linear Superposition: The electric field at a point P is the vector sum of the electric field, \vec{E}_{iP} , produced by each individual charge or charged object

$$\vec{E}_{total} = \sum_i \vec{E}_{iP}.$$

Linear Superposition allows us to build more complicated fields by combining simpler fields. Coulomb's law and the law of linear superposition are really all we need to calculate any electric field since any charge distribution can be subdivided into electrons and protons, which are for our purposes point charges. Their fields can be calculated and added by linear superposition. The following example applies the Law of Linear Superposition to point charges.

Example 5.2 Yet Another Point Charge Problem

Problem: A point charge with charge $q_1 = 3\text{nC}$ is at the location $(2\text{cm}, 3\text{cm}, 0)$. A second point charge with charge $q_2 = -2\text{nC}$ is at the location $(-2\text{cm}, 1\text{cm}, 0)$. Calculate the field a point P at $(1\text{cm}, -3\text{cm}, 0)$.

Solution

(a) Draw Diagram: Use Opposites Attract/ Likes repel to draw the direction of the fields at point P .

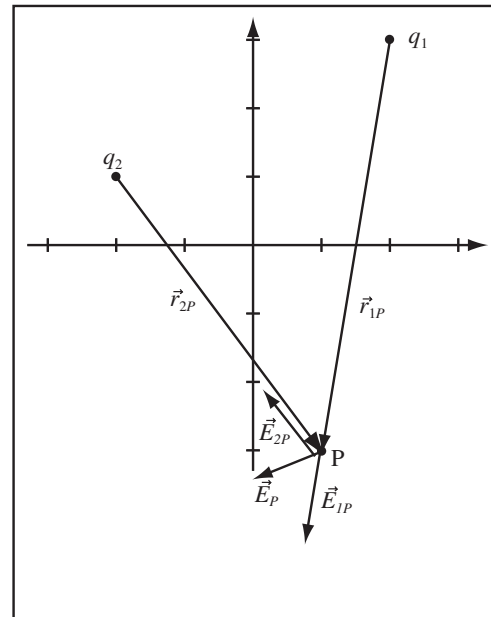

(b) Calculate Field of q_1 : First find the field due to q_1 . The displacement vector, modulus, and unit vectors are

$$\vec{r}_{1P} = \vec{r}_P - \vec{r}_1 = (1\text{cm} - 2\text{cm})\hat{x} + (-3\text{cm} - 3\text{cm})\hat{y} + 0 = -1\text{cm}\hat{x} + -6\text{cm}\hat{y}$$

$$r_{1P} = \sqrt{(-1\text{cm})^2 + (-6\text{cm})^2} = \sqrt{37}\text{cm}$$

$$\hat{r}_{1P} = \left(\frac{-1\text{cm}}{\sqrt{37}\text{cm}}, \frac{-6\text{cm}}{\sqrt{37}\text{cm}} \right) = \left(-\frac{1}{\sqrt{37}}, -\frac{6}{\sqrt{37}} \right)$$

So the field at P due to q_1 is

$$\vec{E}_{1P} = \frac{kq_1}{r_{1P}^2} \hat{r}_{1P} = \frac{(8.99 \times 10^9 \frac{\text{Nm}^2}{\text{C}^2})(3 \times 10^{-9}\text{C})}{(\sqrt{37} \times 10^{-2}\text{m})^2} \left(-\frac{1}{\sqrt{37}}, -\frac{6}{\sqrt{37}} \right) = -1.20 \times 10^3 \frac{\text{N}}{\text{C}} \hat{x} - 7.19 \times 10^3 \frac{\text{N}}{\text{C}} \hat{y}$$

(c) Calculate Field of q_2 : Now find the field due to q_2 . The displacement vector, modulus, and unit vectors are

$$\begin{aligned}\vec{r}_{2P} &= \vec{r}_P - \vec{r}_2 = (1\text{cm} - (-2\text{cm}))\hat{x} + (-3\text{cm} - 1\text{cm})\hat{y} + 0 = 3\text{cm}\hat{x} - 4\text{cm}\hat{y} \\ r_{2P} &= \sqrt{(3\text{cm})^2 + (-4\text{cm})^2} = 5\text{cm} \\ \hat{r}_{2P} &= \left(\frac{3\text{cm}}{5\text{cm}}, \frac{-4\text{cm}}{5\text{cm}} \right) = \left(\frac{3}{5}, -\frac{4}{5} \right)\end{aligned}$$

So the field at P due to q_2 is

$$\vec{E}_{2P} = \frac{kq_2}{r_{2P}^2} \hat{r}_{2P} = \frac{(8.99 \times 10^9 \frac{\text{Nm}^2}{\text{C}^2})(-2 \times 10^{-9}\text{C})}{(0.05\text{m})^2} \left(\frac{3}{5}, -\frac{4}{5} \right) = -4.32 \times 10^3 \frac{\text{N}}{\text{C}} \hat{x} + 5.76 \times 10^3 \frac{\text{N}}{\text{C}} \hat{y}$$

(d) Add Fields Using Linear Superposition: Now, by the principle of superposition of electric fields, we can simply add them up.

$$\begin{aligned}\vec{E}_P &= \vec{E}_{1P} + \vec{E}_{2P} = (-1.20 \times 10^3 \frac{\text{N}}{\text{C}} \hat{x} - 7.19 \times 10^3 \frac{\text{N}}{\text{C}} \hat{y}) + (-4.32 \times 10^3 \frac{\text{N}}{\text{C}} \hat{x} + 5.76 \times 10^3 \frac{\text{N}}{\text{C}} \hat{y}) \\ \vec{E}_P &= -5.52 \times 10^3 \frac{\text{N}}{\text{C}} \hat{x} - 1.43 \times 10^3 \frac{\text{N}}{\text{C}} \hat{y} + 0\end{aligned}$$

5.3 Arrow Diagrams

5.3.1 Representing Electric Fields: Arrow Diagrams

The electric field, and later the magnetic field, are the central objects of electricity and magnetism. We can visualize these fields through two types of diagrams: the arrow or vector diagram described below and the field map which will be covered in Course Guide 7. The simplest way to represent the shape of the field is to use the arrow diagram. An arrow diagram is drawn as follows:

Draw a Fixed Grid: To represent the vector field, select a uniform set of points and draw the field vector at each point with appropriate direction and length.

The First Vector Sets the Length: The first vector you draw sets the scale for all the other vectors.

Reason Using Ratios: Don't compute the actual length of the vectors unless you have to. In the diagram in an example that follows, I used the fact that twice as far from the charge the field is 4 times weaker.

The Field is at the Tail of the Arrow: The vector represents the force or field at its tail, not its point.

Example 5.3 Arrow Diagram for Uniform Field

Problem: Represent a uniform, constant, electric field with direction $(\frac{1}{\sqrt{2}}, \frac{-1}{\sqrt{2}}, 0)$ and magnitude 100N using an arrow diagram.

Solution

Select a set of points. I chose a rectangular array for this problem. Draw the first vector, which will set the scale. Then draw vectors at all of the other points (to scale).

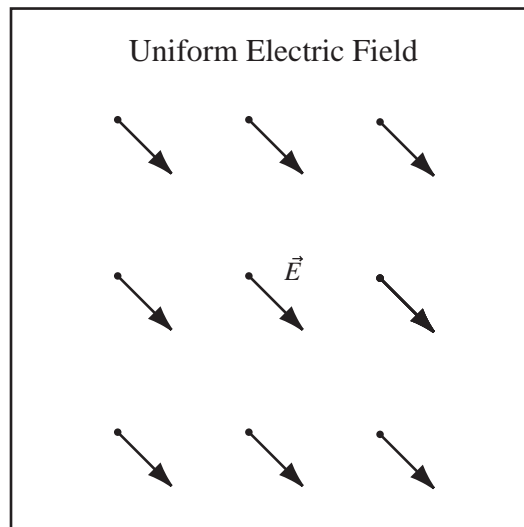

Now let's try the field of a point charge.

Example 5.4 Arrow Diagram for an Isolated Point Charge

Problem: Draw an arrow diagram for a positive point charge.

Solution

The field of a point charge is radial and decays with distance as $1/r^2$. I drew dashed circles of radius d and $2d$. I drew vectors pointing outward on the inner circle of any length I wanted as long as they are all of the same length. These arrows represent the electric field around the inner circle. The field vectors around the outer circle must be $1/4$ the length of those around the inner circle because they are twice as far from Q .

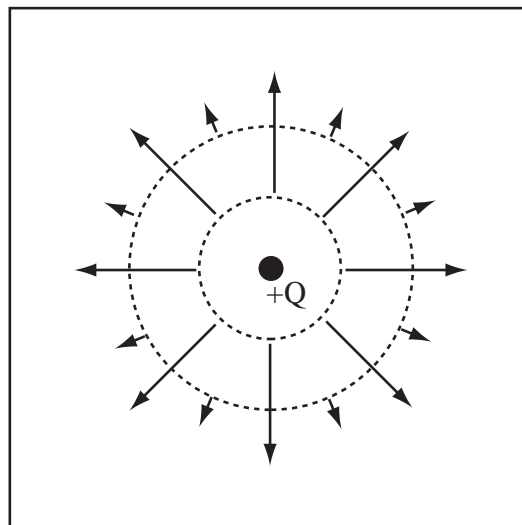

5.3.2 Field and Force

An electric field exerts an electric force on every charged object in the field. The electric force at point P on a charged particle A with charge q_A is $\vec{F}_A = q_A \vec{E}(\vec{r}_P)$ where \vec{r}_P is the location of point P . Note that the force is in the same direction as the field if $q_A > 0$ and the opposite direction if $q_A < 0$. Using this expression, which defines the electric field, we can draw some electric forces on our arrow diagrams.

Example 5.5 Force on a Particle in an Electric Field

Problem: The electric field in the figure to the right is given by $\vec{E}(\vec{r}) = \gamma r \hat{r}$ where $\gamma > 0$.

- Draw the arrow diagram for this field using the dots in the figure to the right.
- Draw the force a $-1\mu\text{C}$ charge would feel if it was placed at point A , point B , or point C .
- Draw the acceleration $-1\mu\text{C}$ would experience at point A .

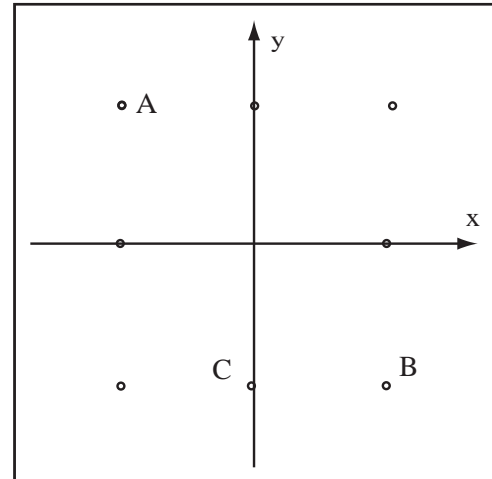

Solution to Part (a)

The electric field points radially outward and increases in strength proportional to the distance. The point B is $\sqrt{2} \approx 1.5$ (1.41) as far from the origin as point C , so $|\vec{E}_B| = \sqrt{2}|\vec{E}_C|$. Using this observation, draw field arrows at each of the dots.

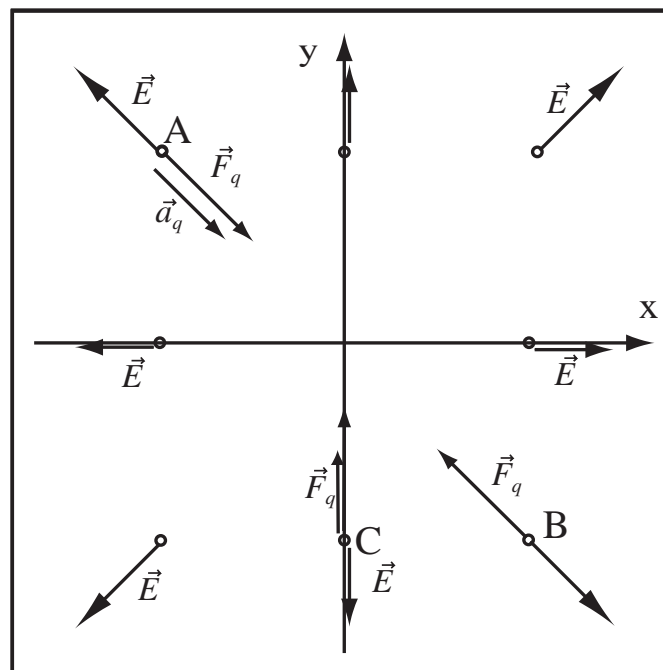

Solution to Part (b)

Since $q = -1\mu\text{C} < 0$, the force vector is opposite the direction of the electric field. The force vectors must be drawn with magnitude proportional to the field since we asked for the force on the same charge.

Solution to Part (c)

The acceleration \vec{a}_q is always in the same direction as the force, since $\vec{F} = m\vec{a}$ and $m > 0$.

5.4 Electric Fields of Lines and Planes

Let's return to our old friends from lab, the pith ball, the wallboard, and the golf tube. The pith ball is well modelled as a point charge whose field has already been introduced. If the point where the electric field is to be calculated is sufficiently close to the wallboard, then the wallboard may be modelled as an infinite plane of charge with uniform surface charge density, σ .

Electric Field of an Infinite Plane of Charge: The electric field of an infinite plane of charge which occupies the $y - z$ plane and has uniform charge density σ is

$$\vec{E}_{x < 0} = \frac{-\sigma}{2\epsilon_0} \hat{x}$$

$$\vec{E}_{x > 0} = \frac{\sigma}{2\epsilon_0} \hat{x}$$

where $\epsilon_0 = 8.85 \times 10^{-12} \frac{\text{C}^2}{\text{Nm}^2}$. Notice, the field does not change with the distance from the plane.

Permittivity of Free Space: The constant $\epsilon_0 = 8.85 \times 10^{-12} \frac{\text{C}^2}{\text{Nm}^2}$ is called the "permittivity of free space" and is one of the fundamental constants of the universe.

Relation of k and ϵ_0 : The constant k found in Coulomb's Law is related to ϵ_0 by

$$k = \frac{1}{4\pi\epsilon_0}$$

Example 5.6 Field of an Infinite Plane of Charge

Problem: Using an arrow diagram, draw the electric field of an infinite plane of charge parallel to the $y - z$ plane with uniform charge density $\sigma > 0$.

Solution

Draw the plane of charge and the x -axis. Choose a collection of points. The electric field to the left of the plane is $-\left(\frac{\sigma}{2\epsilon_0}\right)\hat{x}$ and the electric field to the right of the plane is $\left(\frac{\sigma}{2\epsilon_0}\right)\hat{x}$. So the electric field has the same magnitude at every point and always points outward. Draw the first vector to set the scale and every other vector to that scale.

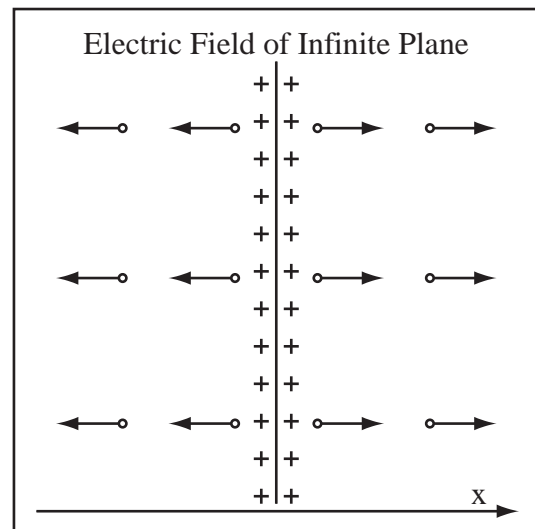

Example 5.7 Electric Field of an Infinite Plane

Problem: An infinite plane with uniform surface charge density $\sigma = 0.03\mu\text{C}/\text{m}^2$ occupies the $y - z$ plane. Compute the electric field everywhere.

Solution

The electric field of an infinite plane of charge is $\vec{E} = \frac{\sigma}{2\epsilon_0}$ outward. Therefore, if the plane occupies the $y-z$ plane and the charge density is positive, then the electric field the $+x$ side of the plane is in the positive \hat{x} direction and the electric field on the $-x$ side of the plane is in the $-\hat{x}$ direction. The magnitude of the electric field is

$$E = \frac{\sigma}{2\epsilon_0} = \frac{3 \times 10^{-8} \frac{\text{C}}{\text{m}^2}}{2(8.85 \times 10^{-12} \frac{\text{C}^2}{\text{Nm}^2})} = 1695 \frac{\text{N}}{\text{C}}$$

The electric field must be reported as a vector, so the electric field of the plane is

$$\vec{E} = 1695 \frac{\text{N}}{\text{C}} \hat{x} \quad x > 0$$

$$\vec{E} = -1695 \frac{\text{N}}{\text{C}} \hat{x} \quad x < 0$$

For the golf tube, we will use the approximation of an infinite straight line with uniform linear charge density λ , when the field point is near the tube, away from the ends, but not inside the tube.

Electric Field of an Infinite Line of Charge: The electric field of an infinite straight line of charge is

$$\vec{E}(\vec{r}) = \frac{\lambda}{2\pi\epsilon_0 r} \hat{r}$$

where \vec{r} points straight outward perpendicular to the line of charge.

Example 5.8 Field of Infinite Line Charge

Problem: Draw the electric field of an infinite line of positive charge along the z -axis using an arrow diagram

Solution

The electric field is cylindrically radial about the z -axis and decreases as $\frac{1}{r}$. So select a set of points at radius d and $2d$ about the line of charge. The magnitude of the electric field at d is twice the magnitude of the electric field at $2d$. Draw the first vector to set the scale, and all other vectors to scale. The vector's length includes its tip. The vector represents the strength of the field at the base of the vector.

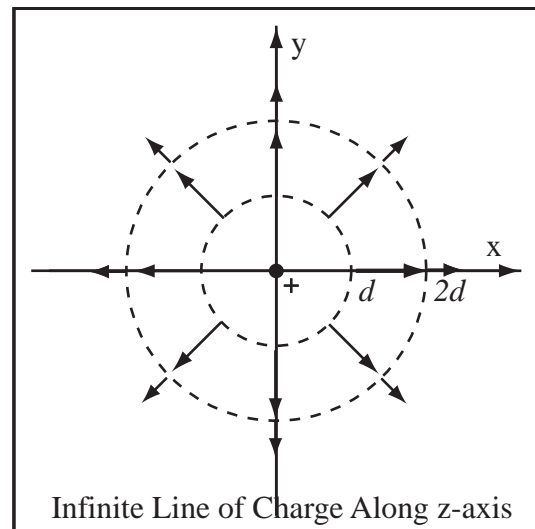

Example 5.9 Golf Tube Example

Problem: The figure below shows a golf tube modelled as an infinite line of charge with charge density $\lambda = -0.1 \frac{\mu\text{C}}{\text{m}} = -1 \times 10^{-7} \frac{\text{C}}{\text{m}}$. Find $\vec{E}_{\text{tube}, P}$. Read the location of the charge and the field point from the diagram.

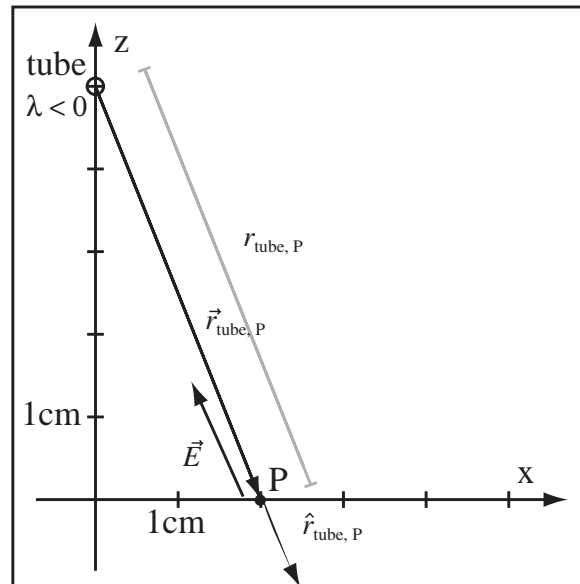

Solution

(a) Displacement Vector: The displacement vector can be read from the diagram. To move from the tube to P , we move $+2\text{cm}$ in the x direction and -5cm in the z direction. From tube to P ,

$$\vec{r}_{\text{tube},P} = (2\text{cm}, 0, -5\text{cm})$$

(b) Calculate the Length of the Displacement Vector:

$$r_{\text{tube},P} = \sqrt{(2\text{cm})^2 + 0^2 + (-5\text{cm})^2} = \sqrt{29}\text{cm}$$

(c) Unit Vector:

$$\begin{aligned} \hat{r}_{\text{tube},P} &= \frac{\vec{r}_{\text{tube},P}}{r_{\text{tube},P}} \\ &= \left(\frac{2}{\sqrt{29}}, 0, \frac{-5}{\sqrt{29}} \right) \end{aligned}$$

(d) Solve for Electric Field:

$$\begin{aligned} \vec{E}_{\text{tube},P} &= \frac{\lambda}{2\pi\epsilon_0 r_{\text{tube},P}} \hat{r}_{\text{tube},P} = \frac{-1 \times 10^{-7} \frac{\text{C}}{\text{m}}}{2\pi(8.85 \times 10^{-12} \frac{\text{C}^2}{\text{Nm}^2})(\sqrt{29} \times 10^{-2}\text{m})} \left(\frac{2}{\sqrt{29}}, 0, \frac{-5}{\sqrt{29}} \right) \\ \vec{E}_{\text{tube},P} &= -3.34 \times 10^4 \frac{\text{N}}{\text{C}} \left(\frac{2}{\sqrt{29}}, 0, \frac{-5}{\sqrt{29}} \right) \end{aligned}$$

5.5 General Vector Fields

Why do we call the electric field a "field"? The electric force \vec{F}_A only exists when the charge q_A is present, but the electric field is always there. The electric field \vec{E} exists at all points in space, so we could draw a field vector at each point. At this point my daughter who was typing this inserted a comment, not to be displayed, "In the infinite cosmos. Dad, you really need to work on your wording. I'm not sure if this is what you meant." But it was what I meant, a charged object produces an electric field, eventually, at every point in the infinite cosmos. Since the electric field exists everywhere, we can write the electric field as a function of the point in space, $\vec{E}(\vec{r})$. This function allows the computation of a value for the electric field vector at each point in space.

By working with non-uniform charge distributions we will produce quite a variety of fields. In this section, we work with $\vec{E}(\vec{r}) = \vec{E}(x, y, z)$ as a general vector function to gain some experience with functions that return a vector.

Example 5.10 Computing the Electric Field at a Point Given the General Field

Problem: The electric field in a region of space is given by

$$\vec{E}(\vec{r}) = x^2 \left(\frac{\text{N}}{\text{Cm}^2} \right) \hat{x} + y^2 \left(\frac{\text{N}}{\text{Cm}^2} \right) \hat{z}.$$

- (a) Compute the electric field at the point $\vec{r}_0 = (2\text{m}, 1\text{m}, 0)$
 (b) Compute the electric force a $-10\mu\text{C}$ charge would feel at \vec{r}_0 .
 (c) Compute the strength of the electric field at \vec{r}_0 .

Solution to Part(a)

Just substitute into the given function; $x = 2\text{m}$, $y = 1\text{m}$, and $z = 0$.

$$\begin{aligned} \vec{E}(\vec{r}_0) &= (2\text{m})^2 \left(\frac{\text{N}}{\text{Cm}^2} \right) \hat{x} + (1\text{m})^2 \left(\frac{\text{N}}{\text{Cm}^2} \right) \hat{z} \\ &= 4 \left(\frac{\text{N}}{\text{C}} \right) \hat{x} + 1 \frac{\text{N}}{\text{C}} \hat{z} \end{aligned}$$

Solution to Part(b)

By the definition of the electric field, the electric force is the field multiplied by the charge q ,

$$\begin{aligned} \vec{F}_0 &= q\vec{E} = (-10\mu\text{C})(\vec{E}(\vec{r}_0)) \\ &= (-10\mu\text{C}) \left(4 \frac{\text{N}}{\text{C}} \hat{x} + 1 \frac{\text{N}}{\text{C}} \hat{z} \right) \\ &= -4 \times 10^{-5} \text{N} \hat{x} - 1 \times 10^{-5} \text{N} \hat{z} \end{aligned}$$

Notice that, because the charge is negative, the force is in the opposite direction as the field.

Solution to Part(c)

The strength of the electric field is the length or magnitude of the electric field vector,

$$\begin{aligned} |\vec{E}| &= \sqrt{E_x^2 + E_y^2 + E_z^2} \\ |\vec{E}(\vec{r}_0)| &= \sqrt{\left(4 \frac{\text{N}}{\text{C}} \right)^2 + 0^2 + \left(1 \frac{\text{N}}{\text{C}} \right)^2} = \sqrt{17} \frac{\text{N}}{\text{C}}. \end{aligned}$$

That's a pretty small field.

There are three general “shapes” of the electric field that we will encounter over and over: the uniform field, the radial field, and the cylindrically radial field. The simplest is the *uniform* field, which has the same magnitude and direction at every point in space.

Definition Uniform Field: A uniform field is one that has the same value at all points in space, so it can be written as $\vec{E} = (C_x, C_y, C_z)$, where the C 's are constant.

Example 5.11 Writing a Uniform Field

Problem: In a region of space, the electric field is uniform, points in the positive x direction and has strength $50 \frac{\text{N}}{\text{C}}$. Write the electric field as $\vec{E}(\vec{r})$.

Solution

Because the field is uniform, if we know the field at one point we know the field at all points. The electric field is $\vec{E}(\vec{r}) = 50 \frac{\text{N}}{\text{C}} \hat{x}$.

The electric field of a single point charge is a *radial* field, which means that at every point in space it is directed either inward or outward along a ray connecting that point in space and the single point charge. The direction of a radial field is given in terms of the unit vector \hat{r} which points outward from the origin at every point.

Definition Radial Field: A field that has the form $\vec{E} = f(r)\hat{r}$, where the vector $\vec{r} = (x, y, z)$ and $f(r)$ is a function only of the distance from the origin is called a radial field. The field points inward or outward along the radius of a sphere.

Example 5.12 Force Due to Radial Field

Problem: In a region of space, the electric field is radial with strength $\gamma\sqrt{r}$ where $\gamma = 1.0 \times 10^2 \text{N/C}\sqrt{\text{m}}$. Compute the force that the field exerts on an object with a charge $q_A = 5.0\mu\text{C}$ located at the point $\vec{r}_A = 5.0\text{cm}\hat{y} + 3.0\text{cm}\hat{z}$.

Solution

(a) **Write the Electric Field:** From the information given, we can write the electric field as

$$\vec{E}(\vec{r}_A) = \gamma\sqrt{r_A}\hat{r}_A,$$

where the \hat{r} directional dependence is deduced from the fact that the field is radial.

(b) **Compute the Vectors:** To compute the field we need the quantities \hat{r}_A and r_A . By definition of vector modulus,

$$r_A = |\vec{r}_A| = \sqrt{0^2 + (5\text{cm})^2 + (3\text{cm})^2} = \sqrt{34}\text{cm}.$$

By definition of unit vector,

$$\hat{r}_A = \frac{\vec{r}_A}{r_A} = \frac{(0, 5\text{cm}, 3\text{cm})}{\sqrt{34}\text{cm}} = \left(0, \frac{5}{\sqrt{34}}, \frac{3}{\sqrt{34}}\right)$$

(c) **Compute the Electric Field:** Substitute into the expression for the electric field.

$$\vec{E}(\vec{r}_A) = \gamma\sqrt{r_A}\hat{r}_A = \left(100 \frac{\text{N}}{\text{C}\sqrt{\text{m}}}\right) \left(\sqrt{\sqrt{34} \times 10^{-2}\text{m}}\right) \left(0, \frac{5}{\sqrt{34}}, \frac{3}{\sqrt{34}}\right)$$

$$\vec{E}(\vec{r}_A) = \left(24 \frac{\text{N}}{\text{C}}\right) \left(0, \frac{5}{\sqrt{34}}, \frac{3}{\sqrt{34}}\right)$$

(d) **Compute the Electric Force:** By definition of electric force, the force on charge q_A due to the electric field is

$$\begin{aligned} \vec{F}_A &= q_A \vec{E}(\vec{r}_A) = (5 \times 10^{-6}\text{C}) \left(24 \frac{\text{N}}{\text{C}}\right) \left(0, \frac{5}{\sqrt{34}}, \frac{3}{\sqrt{34}}\right) \\ &= (1.2 \times 10^{-4}\text{N}) \left(0, \frac{5}{\sqrt{34}}, \frac{3}{\sqrt{34}}\right) \end{aligned}$$

We also encounter electric fields which point radially outward from the axis of a cylinder.

Definition Cylindrically Radial Field: A radial field points outward or inward in all directions from a point in space. A cylindrically radial field points straight outward or inward from a line. A cylindrically radial field will be written $\vec{E}(\vec{r}) = f(r)\hat{r}$ where $\vec{r} = (x, y, 0)$ if the field is cylindrically radial about the z -axis.

5.6 Electric Field of Many Objects

The fields of individual charges and charged objects can be added to form complex fields. The law of linear superposition states that all we have to do is compute the electric field at point P of every charge and charge distribution and add. The law of linear superposition applies to all electric fields, not just the electric fields of point charges. We can calculate the fields of fairly complicated systems of charge by superimposing simpler systems. The examples which follow combine point charges, line charges, and plane charges. As we add new calculation methods in the chapters to come, we will revisit the Law of Linear Superposition, to build continuously more complicated electric fields.

Before we work a really nasty problem involving the field of charged trash that I got at Wal-Mart, we need to understand a trick about writing the individual fields of the objects, the displacement vector. Many of you have probably seen the electric field of a point charge as $\vec{E} = \frac{kq}{r^2}\hat{r}$ but when we wrote it, we wrote the much less pleasant expression,

$$\vec{E}_{12} = \frac{kq_1}{r_{12}^2}\hat{r}_{12}.$$

They are equivalent, but the first expression assumes that the charge is at the origin and in the second expression the charge could be anywhere. The vector \vec{r}_{12} is the displacement of charge 2 from charge 1, the displacement vector. We have to do the same trick for other standard fields. For the example below, we will need the field of a golf tube through the point $1\text{cm}\hat{z}$. We gave the field of the golf tube as $\vec{E}_{tube} = \frac{\lambda}{2\pi\epsilon_0 r}\hat{r}$. To solve the problem (or the related homework problem) you will need to write

$$\vec{E}_{tube,P} = \frac{\lambda}{2\pi\epsilon_0 r_{tube,P}}\hat{r}_{tube,P}.$$

So let's compute the electric field of this assemblage of junk.

Example 5.13 Many Different Fields

Problem: The $x - y$ plane is occupied by a uniform sheet of charge with charge density $\sigma = 1.6 \times 10^{-7}\text{C}/\text{m}^2$. An infinite line of charge runs parallel to the y -axis through the point $-5\text{cm}\hat{x}$ and has charge density $\lambda = 0.5 \times 10^{-6}\text{C}/\text{m}$. A point charge with charge $q = 10\text{nC}$ is placed at the point $+5\text{cm}\hat{x}$. Consider the electric field at a point P at $+5\text{cm}\hat{z}$.

- Draw a good diagram including the direction of the electric field of the three objects at point P .
- Compute the electric field of the infinite plane of charge at point P .
- Compute the electric field of the infinite line of charge at point P .
- Compute the electric field of the point charge at point P .
- Compute the total electric field at point P .

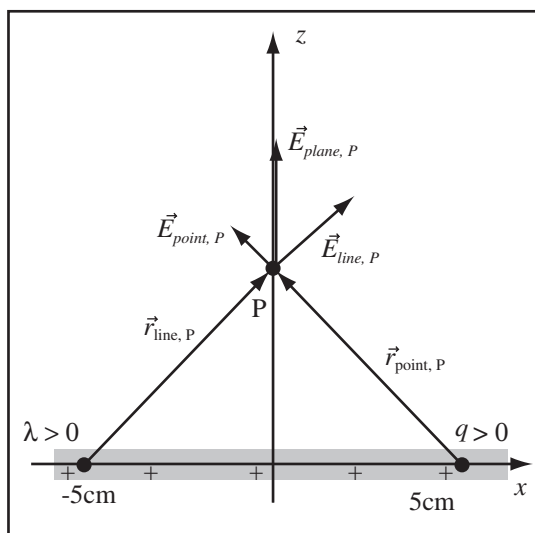

Definitions

- $\vec{r}_{line,P} \equiv$ Displacement Vector from line to P
- $\vec{r}_{point,P} \equiv$ Displacement Vector from point charge to P
- $\vec{E}_{line,P} \equiv$ Electric Field from Line Charge at P
- $\vec{E}_{point,P} \equiv$ Electric Field of the Point Charge at point P
- $\vec{E}_{plane,P} \equiv$ Electric Field of the Plane of Charge at Point P
- $\vec{E}_P \equiv$ Total Electric Field at P
- $\sigma = 1.6 \times 10^{-7}\text{C}/\text{m}^2 \equiv$ Charge Density of Plane
- $\lambda = 0.5 \times 10^{-6}\text{C}/\text{m} \equiv$ Linear Charge Density of the Line Charge
- $q = 1 \times 10^{-8}\text{C} \equiv$ Charge of the Point Charge

Strategy: Compute the electric field of each charge at the point P , then add using linear superposition.

Solution to Part (a)

Draw a Good Diagram: The electric field of the plane charge points straight upward in the $+\hat{z}$ direction. The electric field of the line charge is repulsive and the electric field of the point charge is repulsive. We cannot determine the relative magnitudes of these fields without actually computing the field, so I do not draw an approximation for the resultant on the diagram.

Solution to Part (b)

Compute the Electric Field of the Plane Charge: The electric field of an infinite plane of charge in the $x-y$ plane at a point above the plane is given by

$$\vec{E}_{plane,P} = \frac{\sigma}{2\epsilon_0} \hat{z}.$$

$$\vec{E}_{plane,P} = \frac{(1.6 \times 10^{-7} \text{C/m}^2)}{2(8.85 \times 10^{-12} \frac{\text{C}^2}{\text{Nm}^2})} \hat{z} = 9 \times 10^3 \frac{\text{N}}{\text{C}} \hat{z}$$

Solution to Part (c)

Compute the Electric Field from the Point Charge: The electric field of a point charge at point P is by Coulomb's Law,

$$\vec{E}_{point,P} = \frac{kq}{r_{point,P}^2} \hat{r}_{point,P}.$$

The displacement vector from the point charge to the point P is $\vec{r}_{point,P} = (-5\text{cm}, 0, 5\text{cm})$, by observation of the diagram. The length of this vector is $r_{point,P} = |\vec{r}_{point,P}| = \sqrt{(-5\text{cm})^2 + 0^2 + (5\text{cm})^2} = 5\sqrt{2}\text{cm}$. The unit vector of $\vec{r}_{point,P}$ is by definition

$$\hat{r}_{point,P} = \frac{\vec{r}_{point,P}}{r_{point,P}} = \frac{(-5\text{cm}, 0, 5\text{cm})}{5\sqrt{2}\text{cm}} = \left(-\frac{1}{\sqrt{2}}, 0, \frac{1}{\sqrt{2}}\right).$$

Now, substitute into Coulomb's Law:

$$\vec{E}_{point,P} = \frac{(8.99 \times 10^9 \frac{\text{Nm}^2}{\text{C}^2})(1 \times 10^{-8} \text{C})}{(5\sqrt{2}\text{cm})^2} \left(-\frac{1}{\sqrt{2}}, 0, \frac{1}{\sqrt{2}}\right).$$

$$\vec{E}_{point,P} = 1.8 \times 10^4 \text{N} \left(-\frac{1}{\sqrt{2}}, 0, \frac{1}{\sqrt{2}}\right)$$

$$\vec{E}_{point,P} = (-1.3 \times 10^4 \text{N}, 0, 1.3 \times 10^4 \text{N})$$

Solution to Part (d)

Compute the Electric Field of the Line Charge: The electric field of a line charge is given by

$$\vec{E}_{line,P} = \frac{\lambda}{2\pi\epsilon_0 r_{line,P}} \hat{r}_{line,P},$$

where $\vec{r}_{line,P}$ is the displacement vector from the line charge to the point P . By observation of our diagram, $\vec{r}_{point,P} = (5\text{cm}, 0, 5\text{cm})$. Using the results of the calculations of the previous step, this gives $r_{line,P} = 5\sqrt{2}\text{cm}$ and $\hat{r}_{line,P} = \left(\frac{1}{\sqrt{2}}, 0, \frac{1}{\sqrt{2}}\right)$. Substituting in the formula for the electric field,

$$\vec{E}_{line,P} = \frac{0.5 \times 10^{-6} \text{C/m}}{2\pi(8.85 \times 10^{-12} \frac{\text{C}^2}{\text{Nm}^2})(5\sqrt{2}\text{cm})} \left(\frac{1}{\sqrt{2}}, 0, \frac{1}{\sqrt{2}}\right),$$

$$\vec{E}_{line,P} = (1.3 \times 10^5 \frac{\text{N}}{\text{C}}) \left(\frac{1}{\sqrt{2}}, 0, \frac{1}{\sqrt{2}}\right)$$

$$\vec{E}_{line,P} = (8.99 \times 10^4 \frac{\text{N}}{\text{C}}, 0, 8.99 \times 10^4 \frac{\text{N}}{\text{C}}).$$

Solution to Part (e)

Use Linear Superposition to Add the Fields: The total electric field at point P is the sum of the fields,

$$\vec{E}_P = \vec{E}_{point,P} + \vec{E}_{line,P} + \vec{E}_{plane,P}.$$

$$\vec{E}_P = (-1.3 \times 10^4 \text{N}, 0, 1.3 \times 10^4 \text{N}) + (8.99 \times 10^4 \frac{\text{N}}{\text{C}}, 0, 8.99 \times 10^4 \frac{\text{N}}{\text{C}}) + (0, 0, 9 \times 10^3 \frac{\text{N}}{\text{C}})$$

$$\vec{E}_P = (7.7 \times 10^4 \frac{\text{N}}{\text{C}}, 0, 11.2 \times 10^4 \frac{\text{N}}{\text{C}})$$

Chapter 6

Mechanics

6.1 Mechanics Problems Involving the Electric Force

This section reviews some basic features of mechanics and applies it to the electric force.

6.1.1 Review of Mechanics

We detect net static charge by the force exerted on charged and uncharged objects. A quick review of mechanics may be appropriate at this point.

Newton's Laws Apply to the Electric Force: Just like any other force, we can use Newton's three laws on the electric force.

Newton's First Law: An object continues in its initial state of rest or uniform motion unless it is acted on by an unbalanced or net force.

Deduction I from Newton's First Law: If an object is at rest, the net force on the object is zero.

Deduction II from Newton's First Law: If an object is moving in a straight line with a constant speed, the net force on the object is zero.

Deduction III from Newton's First Law: If an object is turning or changing speed, there is a net force on the object.

What is Net Force?: The net force is the vector sum of all the forces, \vec{F}_i ,

$$\vec{F}_{net} = \sum_i \vec{F}_i.$$

Newton's Second Law: The acceleration, \vec{a} , and net force, \vec{F}_{net} on an object are related by

$$\vec{F}_{net} = \sum_i \vec{F}_i = m\vec{a},$$

where m is the unchanging mass.

Newton's Third Law: (Equal and Opposite Forces) If object X exerts a force \vec{F} on object Y, then object Y exerts a force $-\vec{F}$ on object X.

6.1.2 Mechanics of Systems Involving Tension Forces

Floating or Stationary Masses: If an object is said to be floating, it is assumed to be stationary. If an object is stationary, the net force on the object is zero, by Newton's First Law. Therefore, $\sum \vec{F}_i = 0$. This can be used to solve for one of the forces in terms of the others.

Normal Forces: If an object sits or moves on a surface, like a table top, the table exerts a force on the object perpendicular to the surface. This is called a normal force. The force is large enough to keep the object from accelerating through the surface.

Force of Tension: If an object is partially supported by a string, then the string exerts a force on the object called the tension and denoted by the symbol \vec{T} . The tension of the string must be included in the force balance.

Example 6.1 Pith Ball Floating Due to Electric Force

Problem: A pith ball of mass $0.1g$ is constrained to stay in a vertical tube. When a charged golf tube is placed at the bottom of the tube, the pith ball floats in the air. How much force does the golf tube exert on the pith ball when it is floating and not moving?

Solution

Since the pith ball floats, it is not accelerating. This means that the total force on the pith ball is zero. The forces acting on the pith ball are: the force of gravity \vec{F}_g and the electric force \vec{F}_e . Thus, by Newton's First Law, $\vec{F}_e + \vec{F}_g = 0$. The force of gravity is $\vec{F}_g = -mg\hat{z}$ with \hat{z} pointing upward. Therefore, $\vec{F}_e = -\vec{F}_g = mg\hat{z}$.

$$\vec{F}_e = (0.0001\text{kg})(9.8\frac{\text{m}}{\text{s}^2}) = 9.8 \times 10^{-4}\text{N}$$

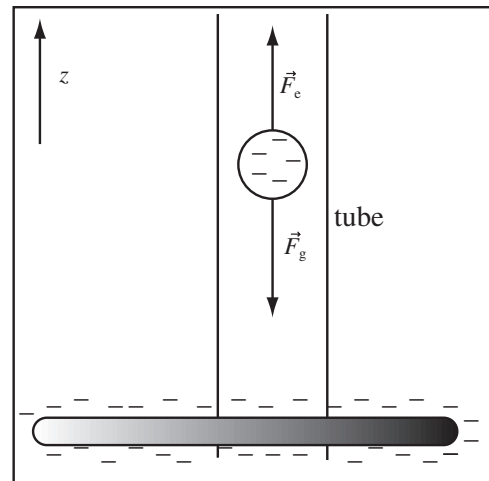

6.2 Mechanics in an Electric Field

Once we have solved the general electrostatic problem for a system of charges, we can let charged objects move in the field. A uniform electric field exerts a constant force on a charged object. The object experiences a constant acceleration by Newton's Second Law. The trajectory of the charge can be predicted using the same kinematic equations you used for motion under the force of gravity.

Recognize Constant Acceleration: If we are given a uniform electric field, it means that the electric field is constant at all points in space, which means the force from the electric field is constant, and the acceleration is constant $\vec{a} = q\vec{E}/m$. This means the formula for motion under constant acceleration (like moving in earth's gravity) can be applied.

Velocity for Constant Acceleration: If we have a constant acceleration, \vec{a} , then the velocity is

$$\vec{v}_t = \vec{v}_0 + \vec{a}t,$$

where \vec{v}_t is the velocity at time t and \vec{v}_0 is the velocity at time zero. For motion in one dimension, along the y -axis for example, this can be simplified to

$$v_t = v_0 + a_y t,$$

where v_t is the velocity at time t in the \hat{y} direction and v_0 is the velocity in the y direction at $t = 0$. Be careful here, a_y , v_t and v_0 are all "signed" numbers, *not magnitudes*, positive if they are in the direction defined as positive in your coordinate system, negative if they are in the opposite direction.

Position Equation for Constant Acceleration: The position after time t of a particle moving with constant acceleration a_y along the y -axis is

$$y_t = y_0 + v_0 t + \frac{1}{2} a_y t^2,$$

where y_t is the position at time t , y_0 is the position at time 0, and v_0 is the velocity at time 0. Again, a_y and v_0 are "signed" numbers, and so are y_t and y_0 .

Time of Flight Equation for Constant Acceleration: The time, Δt , to travel a distance, d , if $v_0 = 0$ is, solving the above equation,

$$\Delta t = \sqrt{\frac{2d}{|a|}}.$$

We can take an absolute value here, because if you start out with $v_0 = 0$ then the displacement and the acceleration will have the same sign. If they have the same sign, then you can just divide the magnitudes, and remember, distance is the magnitude of the displacement, as long as the direction did not change during the motion.

Example 6.2 Motion in a Straight Line

Problem: A charged pith ball is fired down the center of a charged golf tube. Through some method you observe that while it is in the tube it moves in a straight line with constant speed. What can you tell about the force on the pith ball? Justify your answer.

Solution

The net force must be zero, since neither the magnitude of the velocity nor the direction of the velocity is changing, by Newton's First Law.

Example 6.3 Bead Floating above a golf tube

Problem: A bead of charge $2\mu\text{C}$ and mass 1g floats 5cm above a charged golf tube that lies parallel to the ground. Assume this is close enough to approximate the golf tube as an infinite line of charge, and to neglect the Earth's electric field. The bead feels the downward force of gravity.

- (a) What is the electric force on the bead?
- (b) What is the linear charge density, λ , of the golf tube?
- (c) Was it reasonable to neglect the Earth's field?

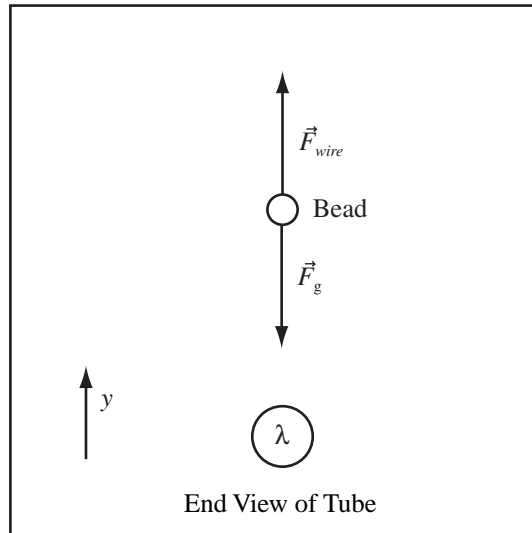

Definitions

 $\vec{F}_E \equiv$ Electric Force

 $m = 1gm \equiv$ mass of charge

 $q = 2\mu C \equiv$ Charge of Floating Mass

 $\lambda \equiv$ Charge per unit length of line charge

 $\vec{F}_g \equiv$ Force of Gravity

 $d \equiv$ Equilibrium Height

Solution to Part (a)

Use Newton's First Law to Balance Forces: Since the charge is motionless, by Newton's First Law

$$\vec{F}_g + \vec{F}_E = 0.$$

The force of gravity is $\vec{F}_g = -mg\hat{y}$. Solving for the electric force gives

$$\vec{F}_E = -\vec{F}_g = mg\hat{y} = (1 \times 10^{-3}\text{kg})(9.81\frac{\text{m}}{\text{s}^2}) = 9.81 \times 10^{-3}\text{N}\hat{y}$$

Solution to Part (b)

(a) Electric Field of an Infinite Line of Charge: The electric field of the line charge is

$$\vec{E} = \frac{\lambda}{2\pi\epsilon_0 r} \hat{r}$$

(b) Find the Charge Density: By definition of electric field, the electric force is $\vec{F}_E = q\vec{E}$. Substitute the formula for the field,

$$\vec{F}_E = +mg\hat{y} = q\vec{E} = \frac{q\lambda}{2\pi\epsilon_0 d} \hat{y}$$

where $d = 10\text{cm}$. Solving for λ and cancelling the vectors gives,

$$\lambda = \frac{2\pi d\epsilon_0 mg}{q}.$$

Solve

$$\lambda = \frac{2\pi(5 \times 10^{-2}\text{m})(8.85 \times 10^{-12}\frac{\text{C}^2}{\text{Nm}^2})(9.81 \times 10^{-3}\text{N})}{2 \times 10^{-6}\text{C}} = 1.36 \times 10^{-8}\text{C/m}.$$

Solution to Part (c)

$$|\vec{E}| = |\vec{F}_E/q|$$

Substitute the force we found,

$$|\vec{E}| = |mg/q| = \frac{9.81 \times 10^{-3}\text{N}}{2 \times 10^{-6}\text{C}} = 4.9 \times 10^3\text{N/C}$$

which is an order of magnitude bigger than the Earth's electric field of 150N/C.

Example 6.4 Compute the Time for an Electron to Accelerate in a Field

Problem: The ratio of the charge to the mass is important in finding the acceleration of a charged particle.

- Compute e/m for a proton.
- What is acceleration of a proton in a uniform electric field of $\vec{E} = 100\text{N/C}\hat{x}$?
- Nonrelativistic mechanics can be used only if the speed of the proton is significantly less than the speed of light $c = 3 \times 10^8 \frac{\text{m}}{\text{s}}$. Compute the time it takes for a proton placed in this field to reach a speed of $0.01c$ if it starts from rest.
- How does this compare to the time it would take for an electron to reach this speed in this field?

Strategy: Use equations of the mechanics of motion during constant acceleration.

Solution to (a)

The ratio of e over m_p is

$$\frac{e}{m_p} = \frac{1.6 \times 10^{-19}\text{C}}{1.67 \times 10^{-27}\text{kg}} = 9.58 \times 10^7 \frac{\text{C}}{\text{kg}}$$

where e is the charge of the proton and m_p is its mass.

Solution to (b)

The acceleration of a proton by Newton's Second Law is $\vec{a} = \vec{F}_p/m_p$ where \vec{F}_p is the net force on the proton. If the force is provided by an electric field \vec{E} , then $\vec{F} = e\vec{E}$ by definition of the electric field, therefore

$$\vec{a} = \frac{e}{m_p}\vec{E} = 9.58 \times 10^7 \frac{\text{C}}{\text{kg}}(100 \frac{\text{N}}{\text{C}}\hat{i}) = 9.58 \times 10^9 \frac{\text{m}}{\text{s}^2}\hat{i}$$

Solution to (c)

Since the electric field is constant, and therefore the acceleration is constant we can use $v = |\vec{a}|t$ if the proton starts from rest, where v is the velocity at time t . The time, $t_{0.01c}$ to reach $v = 0.01c$ is

$$t_{0.01c} = \frac{v}{|\vec{a}|} = \frac{(0.01)(3 \times 10^8 \frac{\text{m}}{\text{s}})}{9.58 \times 10^9 \frac{\text{m}}{\text{s}^2}} = 3.1 \times 10^{-4}\text{s}$$

Solution to (d)

An electron is far lighter than a proton, so from the equation in part (b), the acceleration would be far greater, and therefore the time to reach $0.01c$ far less.

Chapter 7

Electric Field Maps

For the rest of this class, the field map will be used as the primary representation of both electric and magnetic fields. This chapter develops the skills needed to draw these very useful diagrams.

7.1 Gauss' Law, Field Lines, and Field Maps

7.1.1 Introduction to Gauss' Law

In Course Guide 5, we worked with Coulomb's Law for the electric field, $\vec{E}_P = \sum \frac{kq_i}{r_{iP}^2} \hat{r}_{iP}$, which allows the calculation of the electric field if we know the location of all the charge. Both charge and field are equally important. Therefore, it should be possible to reformulate Coulomb's Law to allow the computation of the charge from the field. The reformulation is called *Gauss' Law*. In this chapter, we first work with a version of Gauss' Law with all the mathematics removed, applying it to a new representation of the electric field called a *field map*. Typically, a physical law is not named after a mathematician for manipulating another physical law, but Gauss was quite a mathematician.

Gauss' Law (Version 0): The net number of electric field lines exiting any closed surface is proportional to the charge enclosed in that surface.

$$Q \propto \text{lines.}$$

Definition of Open and Closed Surfaces: A *closed surface* will, metaphorically, hold water. An *open surface* will not. A filled balloon is a closed surface, but a popped balloon is an open surface. A shoe box with the lid on is a closed surface. A shoe box with the lid off is an open surface.

Definition of Field Line: A field line is a graphical object, a representation of the electric field. IT IS NOT A REAL PHYSICAL THING. A field line is a line drawn such that the electric field is tangent to the line (pointing in the direction of the line) at all points along the line. Therefore, if you are given a field line you should be able to draw the direction of the electric field vector at each point along the line.

The diagram to the right shows the arrow diagram of an electric field and a few field lines. Observe carefully, the field line is drawn such that it is tangent to the vectors at each point it passes through and interpolates between the directions of adjacent vectors when it passes between two vectors. Given a field line or a collection of field lines (called a field map with additional restrictions), I would expect you to be able to draw the electric field vectors at a set of points. It is also fair game to ask you for the direction of the force on a given charge and the direction of the acceleration. In the example which follows, the electric field vectors are subtracted from the diagram, with a few of the missing field lines added.

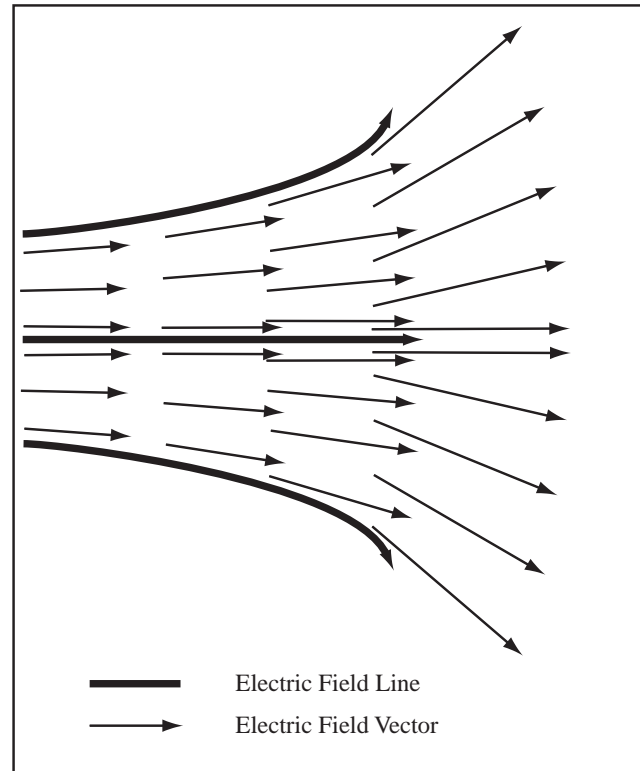

Example 7.1 Drawing Field Vectors Given a Field Map

Problem: The diagram to the right shows the electric field lines for some charge distribution.

- At three points on each line, draw the electric field vector.
- For three of the electric field vectors drawn, draw the direction of the electric force on an electron. Draw the acceleration of an electron at one of the electric force vectors.

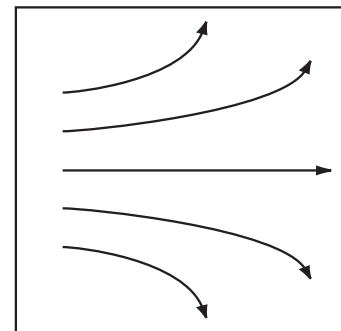

Solution to Part(a)

The electric field vectors are at every point tangent (point in the same direction as) the electric field lines. Some of the field vectors are drawn slightly off the field lines so they can be seen.

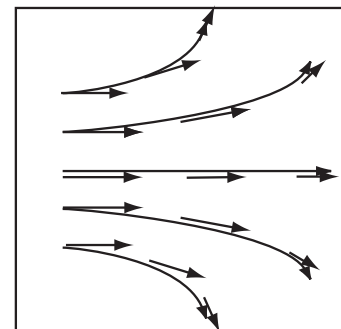

Solution to Part(b)

An electron has a negative charge. By definition of the electric field, $\vec{F} = q\vec{E}$, the force on a negative charge points in the opposite direction to the electric field. Since $\vec{F} = m\vec{a}$ and the mass $m > 0$, the acceleration \vec{a} points in the same direction as the force.

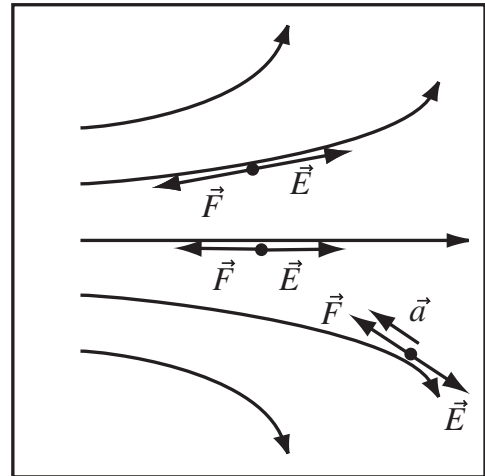

Gauss' Law states that the net number of field lines leaving a closed surface is proportional to the net charge in the surface, but it looks like I can draw field lines anywhere. To draw a representation of the electric field to which Gauss' law can be applied an additional constraint on the drawing of field lines must be imposed.

Definition Electric Field Map: An electric field map is a representation of the electric field using field lines, where

- The number of field lines leaving or entering any charged object is consistent with Gauss' Law.
- The distance between field lines is inversely proportional to the strength of the electric field.

Electric fields occupy three dimensional space, but our field maps are two dimensional, which is hard enough to draw. Therefore, we are projecting a three dimensional image onto a two dimensional drawing. We introduce errors by doing this. Our field maps should correctly be thought of as extending uniformly into and out of the paper. We ignore this approximation because the field maps we draw have the correct shape and all reasoning proceeds correctly using the two dimensional image. When a field map of a point charge or spherical system is presented, it is actually the field map of a cylindrical system extending infinitely into the page. If this is unclear, ignore it, because everything will work out beautifully. (The upshot is, you cannot use field maps to determine the exact ratio of point charge field strengths at different distances by measuring the separation of the lines, because you drew 3 dimensions worth of lines in only 2 dimensions.)

The electric field map we have been working with is drawn for a region of space containing no net charge. How do I know? Gauss' Law states that the charge enclosed in any closed surface is proportional to the electric field lines exiting the surface. A closed surface (dashed line) is drawn on the figure to the right. I count four field lines entering the surface and four field lines exiting the surface, therefore zero net field lines exit the surface and by Gauss' Law the net charge enclosed is zero. Anywhere I draw a surface on the diagram to the right, I will find zero net field lines exiting the surface, therefore there is no net charge anywhere in the region of space where this field is drawn. Cool! We can do physics just by counting lines.

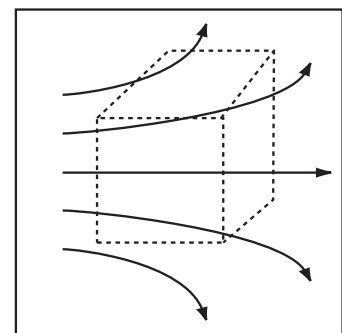

I hope as you considered moving the Gaussian surface around the field map, you started to wonder what a field map containing net charge would look like. Simple, to produce a closed surface with net lines entering or exiting the surface, field lines must start or end within the surface. The surface to the right shows net lines entering the surface. Gauss' Law states that the net field lines EXITING a surface is proportional to the net charge enclosed in the surface. If net lines exit, the charge enclosed is positive; if net lines enter, then the charge enclosed is negative. In the figure at the right, net field lines enter the surface (the lines point inward), therefore the charge enclosed is negative. In this way, we can use Gauss' law to locate charge in a field map.

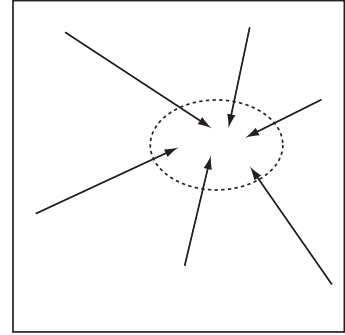

Lines Begin on Positive Charge and End on Negative Charge: Electric field lines begin on positive charges and end on negative charges or infinity.

7.1.2 Reading Electric Field Maps

Field lines may not cross. The electric field points in the direction of the field line at each point on the field line. Therefore, if two field lines were to cross, the electric field would point in two different directions at the point they cross. This is NOT ALLOWED. The electric field has a unique direction at each point in space, therefore

Field Lines Do Not Cross: If two field lines cross, then the electric field would have two different values at the same point in space. That can't happen.

Field maps are drawn so that the distance between field lines is inversely proportional to the magnitude of the electric field. This means that the relative magnitudes of the electric field at different places in space can be read off the field map by comparing the separation of field lines. We can't get the exact ratio, though, since we are drawing 3 dimensions worth of lines in 2 dimensions.

Density of Field Lines is Proportional to Magnitude of the Electric Field: The density of lines is proportional to the magnitude of the field.

Far from a Net Charge the Field is Radial: Far from a distribution of charge with non-zero net charge, the electric field points radially outward just like the field of a point charge.

Drawn below is the arrow diagram and field map for a positive point charge. Comparing the two diagrams, we can see that the field lines point in the direction of the electric field. In the arrow diagram the strength of the electric field, $|\vec{E}|$, is represented by the length of the vector. In the field map the strength of the field is represented by the separation of the lines, so in the field map we can tell that the field is stronger at point A than point B because the lines are closer together. Notice, the field map does not produce the correct length for \vec{E}_A and \vec{E}_B . Since the point A is one third the distance from the charge as point B , the field at B should be $1/9$ the magnitude of the field at A . The field line separation is only 3 times more at point B than at point A rather than the 9 times we would expect. Note, this is exactly correct if the charge were an infinite line charge. This is because we have flattened the three-dimensional field to two dimensions.

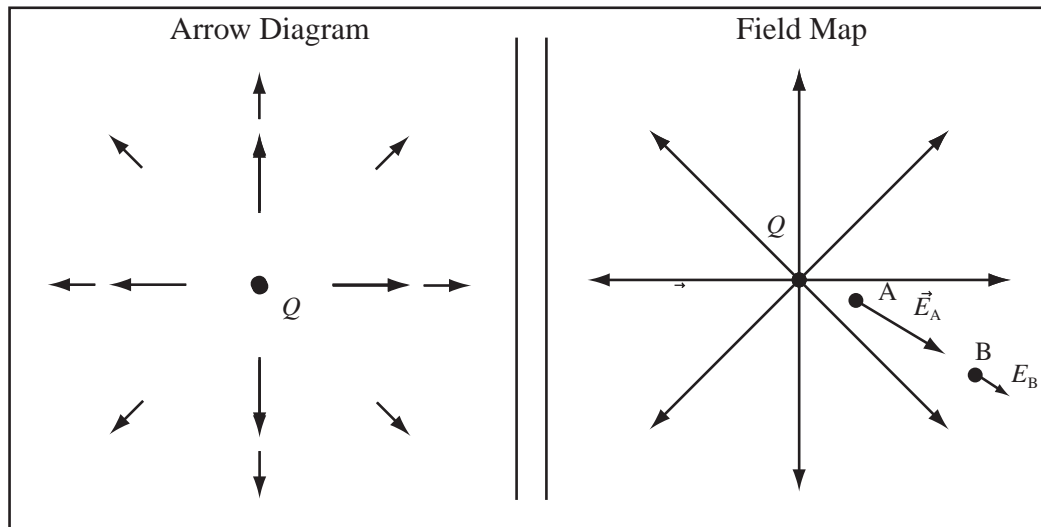

Example 7.2 Reading Field Map for Unequal Point Charges

Problem: Consider the electric field map drawn to the right. The magnitude of the total charge of the system is $|Q|$.

- What is the total charge (including the sign) contained in the dashed line C ?
- How much charge is contained inside the dashed line A ?
- How much charge is contained inside the dashed line B ?
- Compare the size and direction of the electric field at points D and E .

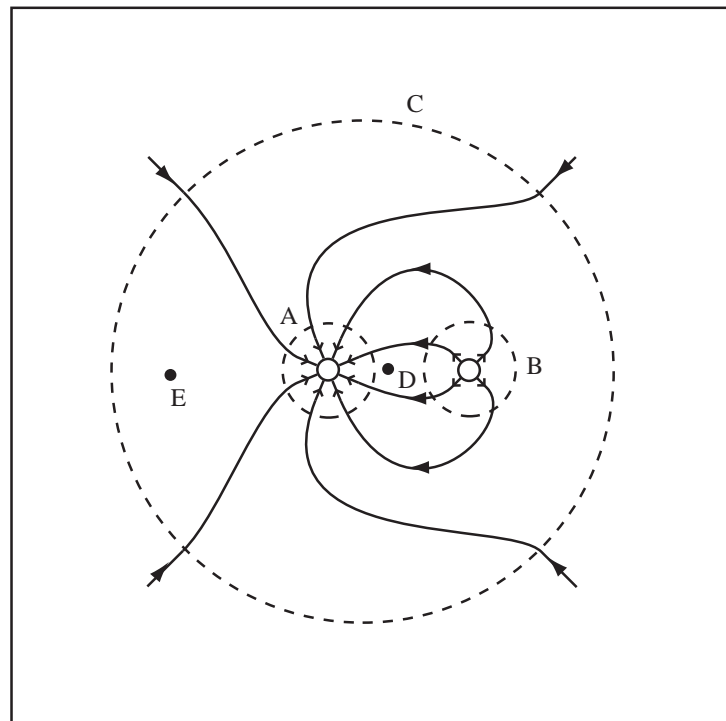

Solution to Part(a)

Far from a charge distribution, the field lines become radial (point straight outward), and behave as if coming from a point charge with the total charge of the distribution. Since field lines enter C , it must contain a net negative charge. We are given the magnitude of the total charge as $|Q|$, so the total charge must be $-|Q|$. Let this be written as $-Q$.

Solution to Part(b)

Four field lines enter C and eight field lines enter the surface A . Since field lines enter the surface, the charge enclosed in A is negative. The number of field lines entering or leaving a surface is proportional to the charge.

Since twice as many lines enter A as enter C , the charge enclosed by A is twice the charge enclosed by C . Therefore, the charge enclosed by surface A is $-2Q$.

Solution to Part(c)

Four field lines enter C and four field lines exit the surface B . Since field lines exit the surface, the charge enclosed in B is positive. Since the same number of lines leave surface B as enter surface C , the charge enclosed by B is negative the charge enclosed by C . Therefore, the charge enclosed by surface B is Q .

Solution to Part(d)

The electric field points in the direction of the field lines. For D the field lines point to the left, so the electric field, \vec{E}_D , is directed to the left. For E the field lines point to the right, so the electric field, \vec{E}_E , points to the right. Notice I had to interpolate between field lines to get the direction at these points. The magnitude of the electric field at point D is larger than the magnitude of the electric field at point E because the field lines are closer together at D , $|\vec{E}_D| > |\vec{E}_E|$.

7.2 Drawing Electric Field Maps

7.2.1 Finding the Near and Far Fields of a System of Charge

The field mapping algorithm presented in this section works by figuring out the shape of the field map very near the charges and very far from the charges and matching the two shapes. Very far from a system with net (non-zero) charge, all the charge appears to be at the same point, therefore the electric field is the electric field of a point charge whose charge is equal to the total charge of the distribution. This electric field is radial. If the total charge of the system is zero, this reasoning does not apply. Course Guide 8 covers systems with zero net charge.

For a system of point charges, we can also figure out what the field looks like very close to a point charge. Since $E \propto 1/r^2$ the magnitude of the electric field goes to infinity near a point charge (you may assume quantum field theory cuts off the singularity close enough to the charge). Therefore, very close to a point charge the electric field is radial, since the electric field of the charge you are near dominates the field of all the other charges. This also means the electric field leaves a point charge symmetrically.

Field Lines Leave Charge Symmetrically: The lines leave a point charge symmetrically.

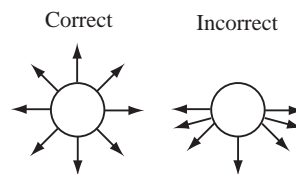

Everything is Radial Far From a Net Charge: At large distances from any non-zero charge, the lines are equally spaced and radial just as they would be for a point charge with $Q =$ total charge of the system.

7.2.2 Drawing Electric Field Maps

The electric field map will be our primary way of representing the electric field, and later we will use the magnetic field map to represent magnetic fields. We use it because it is simple to draw and it shows the shape of the field everywhere. Use the following process to draw an electric field map.

Draw the Location and Strength of the Charges: Leaving plenty of room, draw circles where the electric charges are located. Label each circle with the strength of the charge.

Select a Number of Lines Per Charge: The number of field lines entering or leaving a charged object is proportional to the charge of the object. If we have point charges $q_1 = 5\mu\text{C}$, $q_2 = -10\mu\text{C}$, I might randomly select four lines to represent q_1 , therefore eight lines represent q_2 .

Draw Stubs of Field Lines: Draw little arrows on the charges for the number of lines selected. Arrows should point out for positive charge and in for negative. Near a point charge the field lines are radial, since $E \rightarrow \infty$ as $r \rightarrow 0$. This means that the field line stubs should be evenly spaced around the charge.

Draw the Long Range Field: Far from a charge distribution, the electric field will have a characteristic shape. For distributions with a non-zero net charge, the electric field far from the charges will be that of a point charge with a charge equal to the total charge of the distribution. If we continue with q_1 and q_2 above, far from the charge we will see a radial field equal to that of a point charge with charge $q_t = q_1 + q_2 = -5\mu\text{C}$. Draw a dashed circle far from the charges, which is called the circle at infinity. Draw the appropriate number of field lines leaving or entering this circle. For q_1 and q_2 , if four lines leave $q_1 = 5\mu\text{C}$, then four other lines must enter the circle at infinity since $q_t = -5\mu\text{C}$.

Connect the Stubs Without Crossing the Field Lines: Field lines do not cross, since the electric field has a single direction at every point in space. (As Egon said, "Do not cross the streams. . . It would be bad.") To finish the map, simply connect the field lines on the stubs and the field lines at infinity, without crossing the lines. A line may not begin and end with stubs pointing in different directions.

Respect Symmetry: The symmetry of your field map is affected by the initial choice of stub directions, your choices for the field at infinity, and how you connect the stubs. The field you end up with should have the same symmetry as the charges you started with.

Let's apply this process to the drawing of the electric field of one and two point charges.

Example 7.3 Drawing the Electric Field Map of One Point Charge

Problem: Draw the electric field map of one point charge : $+Q$.

Solution

(a) Draw and clearly label location of all charge: Compute the total charge of each object. Draw each object and label it with its total charge. In this case we have only one charge which we will label Q .

(b) Select a number of lines for a certain amount of charge: Select a number so that a minimum of 2 lines (preferably at least 4) are associated with an object. Use this to associate a number of lines proportional to the charge with each object. For this problem use $Q = 8$ lines.

(c) Draw Stubs in the Direction of the Field Lines: Draw stubs for the number of field lines. $Q = 8$ field lines evenly spaced around the charge. The electric field is the electric force divided by the charge. So if I put another $+q$ near the $+Q$ charge it will be pushed outward. [Like charges repel] So for the $+Q$ charge, the field lines point away from the positive charge.

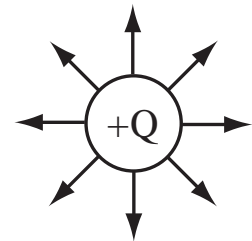

(d) Compute total charge of system and draw the field at ∞ : Draw a circle at infinity. Compute the number of lines for the total charge and draw stubs with direction arrows on the circle at infinity. For this case, the total charge is Q so there are 8 stubs pointing outward.

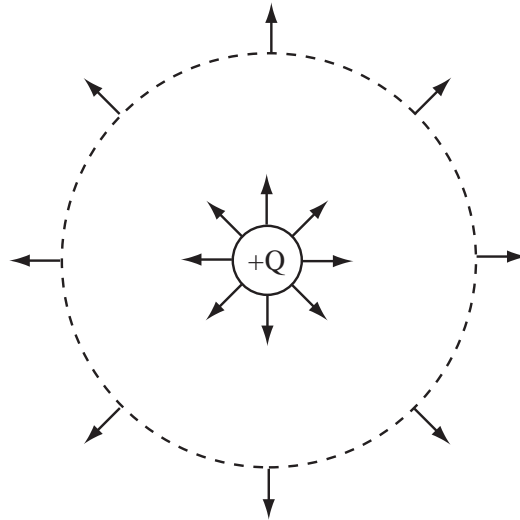

(e) **Connect the lines:** Connect the lines coming off of the charge to the circle at infinity. Bend things smoothly so that each positive line emerging from a positive stub ends on a negative stub or on a positive stub on the circle at infinity. Do not cross the lines, remember that electric field lines do not cross because this would mean that the electric field had two values at one point in space.

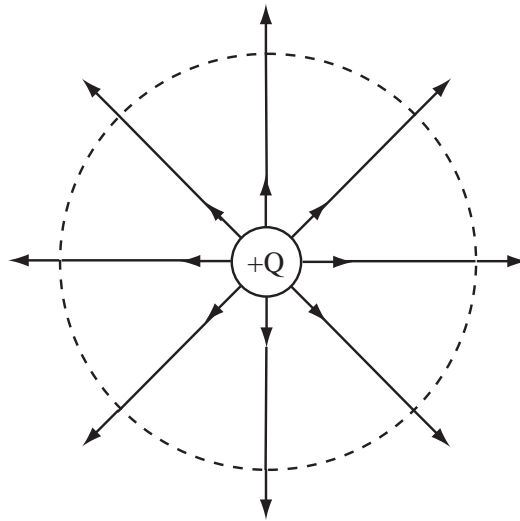

(f) **Shake it up:** Either the drawing will look great or weird. If it looks great, you're finished. Congratulations. If it looks weird, you need to rotate the stubs you initially drew and redraw until it doesn't look weird.

Example 7.4 Draw Electric Field of Two Positive Point Charges

Problem: Two charges $+Q$ and $+Q$ are located at $x = \pm 1\text{cm}$ on the x -axis, draw the electric field.

Solution

Strategy: Use general method of drawing electric field maps.

(a) Draw Charges and Field Stubs: Draw the locations of the charges and label their strengths. Select a number of field lines per charge. I pick $Q \propto 8$ field lines. Field lines exit a positive charge. Draw the field line stubs exiting the charge.

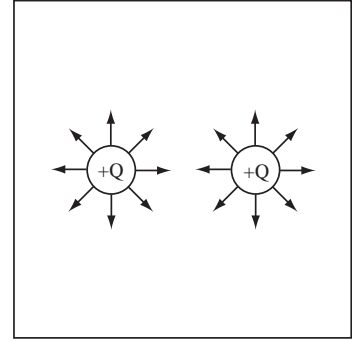

(b) Draw the field far from the charges: We have a total charge of $2Q$, so we need 16 field lines at ∞ .

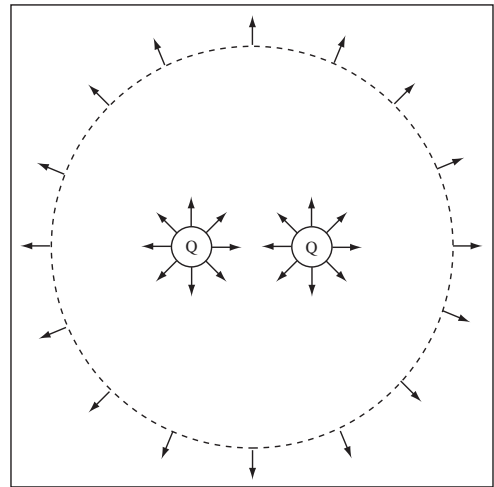

(c) Connect the Lines: Connect the stubs on the charges to the stubs at ∞ without crossing the field lines.

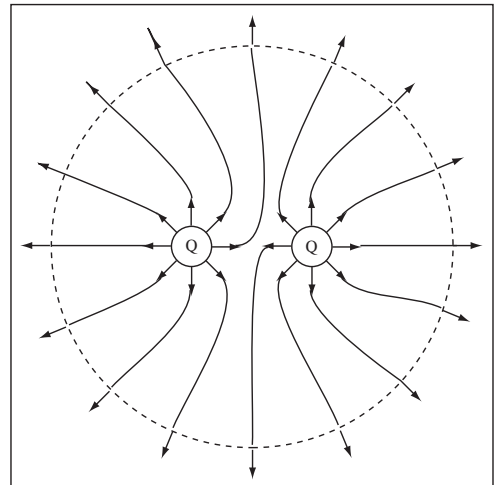

(d) Respect the Symmetry: The charges are the same, therefore the field lines come out from each charge in the same way. The field stubs I chose did not create an appropriately symmetric picture, so the stubs had to be rotated. After rotating the field stubs, the correct figure is drawn to the right.

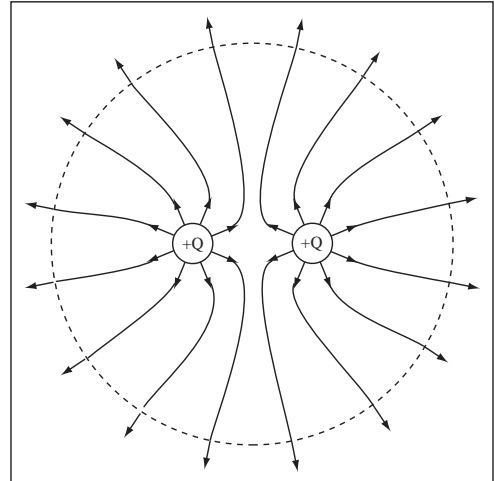

7.3 Drawing Arbitrary Continuous Fields

Approximate Continuous Distribution with Point Charges: To draw the field of a continuous object replace the object with a few point charges that have the same total charge, then draw the field just as we have been drawing point charge fields.

Example 7.5 Field Map Two Half Spheres

Problem: Draw the electric field map of the two half circles with equal and opposite charges. Approximate each line with three charges using 12 lines per half circle.

Solution

(a) Draw the system: The system of charge is drawn to the right.

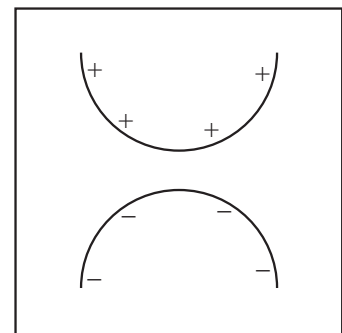

(b) Approximate the Continuous Distribution with Point Charges: The problem asks for three point charges and 12 total lines, so each charge has four lines. Field lines leave positive charges and enter at negative charges.

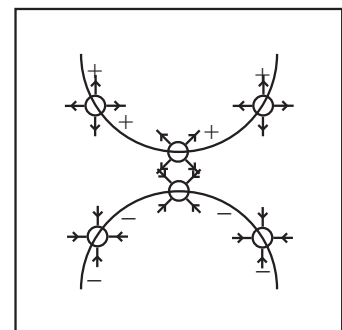

(c) **Connect Everything Up:** I had to shorten some of my stubs to get this one to look right. Notice, since the net charge is zero, no lines exit to infinity. This is a dipole system which will be covered in more detail next chapter.

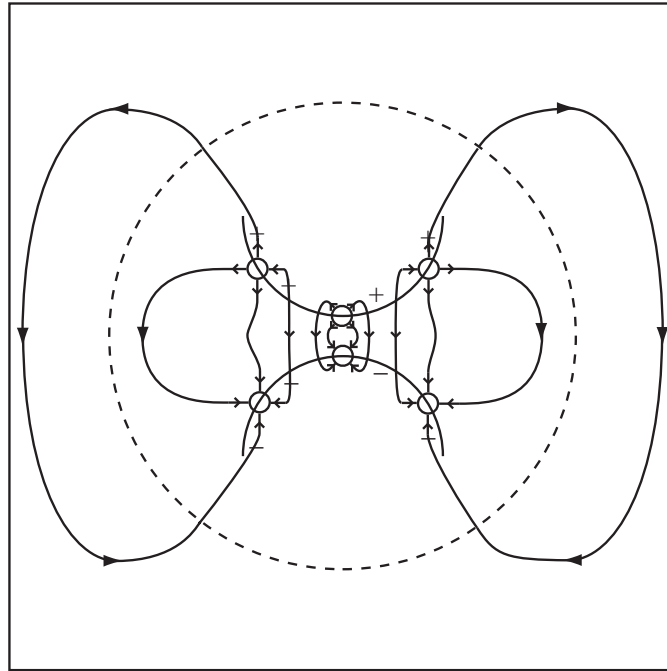

7.4 Combining Arrow Diagrams and Field Maps

As you have begun to work with more complicated field maps with more charges and more lines, you have encountered points where you had to make a choice about which line went where. These are real physical choices since different choices change the relative separation of lines on your field map and therefore the strength of the field. The proper way to resolve this ambiguity is to combine the field map and the arrow diagram. Before beginning the field map, chose a small number of points and draw the field vectors with approximately the correct length. Use these vectors a guide when you have to make choices when connecting the field lines.

Reason About Field Strength: As we draw more complicated field maps, it becomes more difficult to decide how to connect the field lines. This means we have to begin to reason about where the field is strong and weak to get a good field map. The best way to do this is to draw the field vectors at a few points.

Example 7.6 Draw Field of Single Half-Circle of Charge

Problem: Draw the electric field map of a half-circle of positive charge. Approximate the circle using three point charges, with a total of twelve lines.

Solution

(a) Approximate the Object by a Series of Point Charges:

Approximate the linear charge by three point charges, each with four field lines. The total number of lines escaping to infinity is $3 \times 4 = 12$ lines. Draw the circle at infinity and 12 lines leaving.

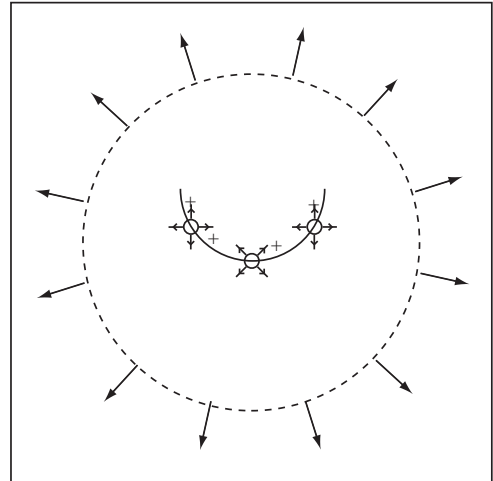
**(b) Connect The Lines:**

Connect the lines without crossing. Examine the field map and realize something's wrong. We know that inside the half circle, the field must be weaker because of cancellation. If it were a full circle, the field would be zero. In the field map we drew, the field lines are closer together, indicating a stronger field. We must have made a mistake selecting what stub went to which line at infinity. Unfortunately, as the systems of charge become more complicated and have less symmetry, this kind of reasoning about relative strengths becomes necessary.

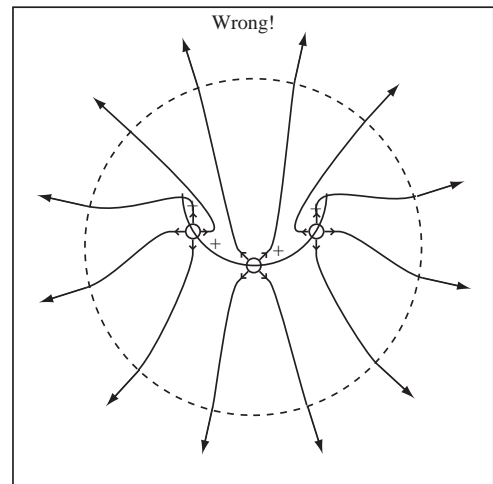
**(c) Reason about the field strength:**

Consider the points *A* and *B* on the figure to the right. The contribution of the middle charge is the same at each point. For point *A*, the contribution of the two outer charges exactly cancels, but for point *B* the two outer charges have a positive contribution. Therefore, the electric field is stronger at point *B* than at point *A*. Draw appropriate field vectors

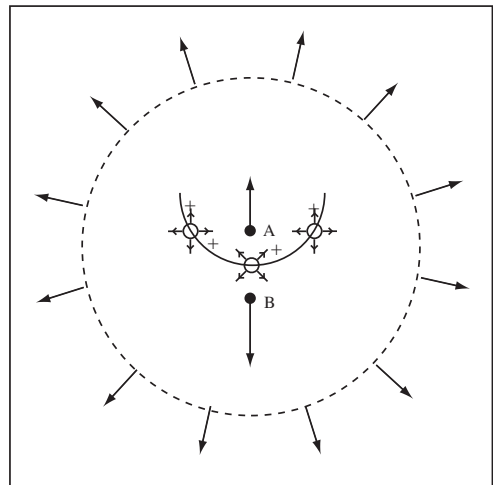

(d) Connect the Lines Choosing Different Stubs for the Central Charge: Reconnect the lines with a small change in what stub goes where, giving a field map that has a weaker field inside the half-circle. Note, the field spacing is consistent with the vectors we drew.

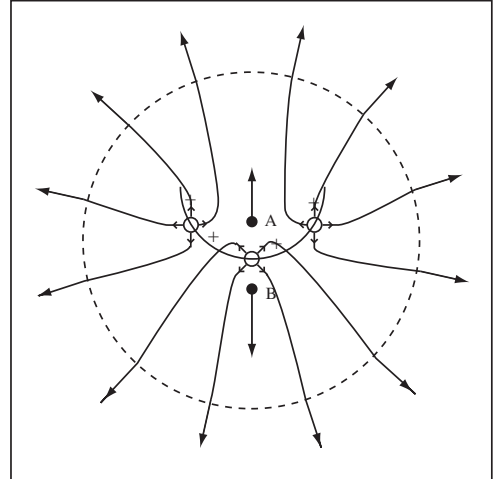

Chapter 8

Electric Dipoles

It requires a lot of energy to produce a net charge, so most objects do not have a net charge. All objects however contain charge and often the centers of positive and negative charge in an object are at different locations. The behavior and shape of the electric field of these systems is determined by their *electric dipole moment*.

8.1 Behavior of Electric Dipoles

This section covers skills and problems involved in drawing dipole fields, deducing the direction of dipole moments from fields, and predicting the behavior of dipoles in the field of other charge. When drawing field maps for systems with non-zero total charge, we use the fact that, far from a distribution of charges with non-zero net charge, the electric field is radial. What happens when the total charge of the distribution is zero? Let's draw it. Using eight stubs per charge, the field for equal and opposite point charges is drawn below. The dashed circle is the circle at infinity, which we have been using for fields with net charge. Note that no lines escape to infinity, which is correct because the system has zero net charge. The shape of the field outside the dashed line is the characteristic shape a dipole field. The strength of a dipole is given by a vector \vec{p} , the dipole moment.

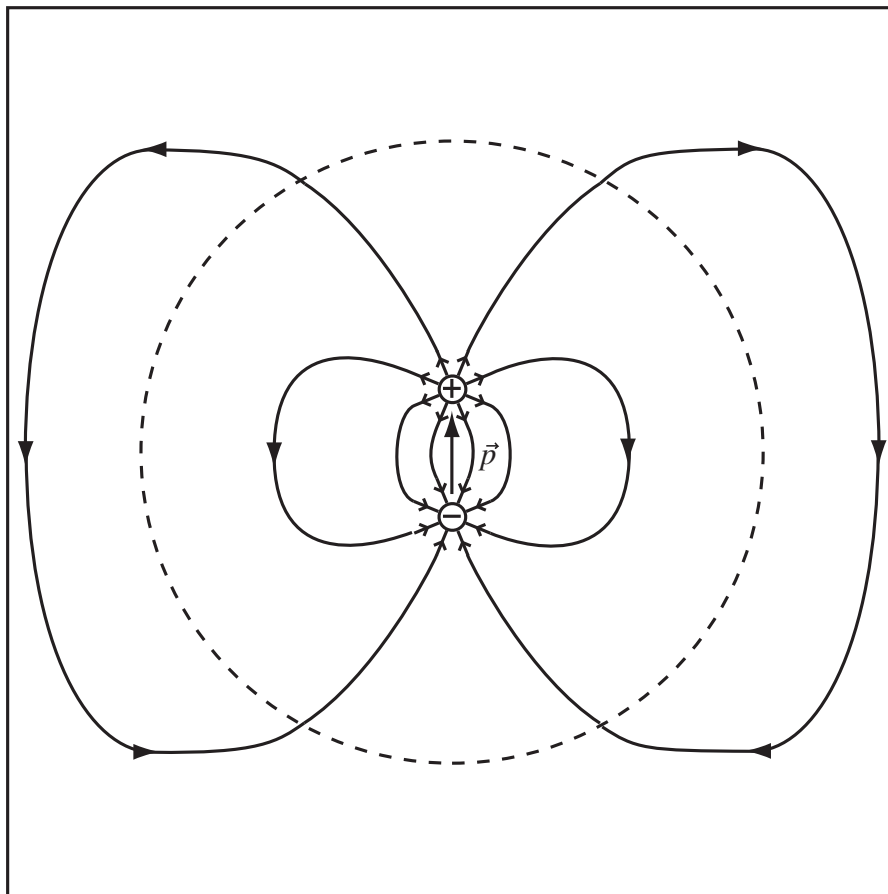

Moments of the Electric Field: Any electric field can be expressed as a series of characteristic fields whose strength is determined by their “moment”. The net charge of a system is the system’s monopole moment. The next moment is the dipole moment, defined below. Higher order moments exist: quadrupole, octopole, etc. The long range shape of the field is determined by the lowest order non-zero moment. The long range shape of a system with net charge is radial, determined by its monopole moment. If monopole moment is zero and the dipole moment non-zero, the long range shape is dipole.

Definition Dipole Moment Vector: The dipole moment vector for a system with zero net charge, \vec{p} , can be calculated for a collection of charges q_i located at the points \vec{r}_i using

$$\vec{p} = \sum_i q_i \vec{r}_i$$

Example 8.1 Dipole Moment of Three Charges

Problem: A 2nC charge is at the origin. Two -1nC charges are at $(1\text{cm}, 0, 0)$ and $(1\text{cm}, 1\text{cm}, 0)$. Calculate the dipole moment vector.

Solution

The dipole moment vector is by definition

$$\vec{p} = \sum_i q_i \vec{r}_i = (2\text{nC})(0, 0, 0) + (-1\text{nC})(1\text{cm}, 0, 0) + (-1\text{nC})(1\text{cm}, 1\text{cm}, 0)$$

$$\vec{p} = (-2 \times 10^{-11} \text{Cm}, -1 \times 10^{-11} \text{Cm}, 0)$$

Dipole Moment for Equal and Opposite Charges: For a dipole formed of two equal and opposite point charges, the dipole moment points from the negative charge to the positive charge and has magnitude $p = qd$ where d is the separation between the charges and q is the charge of the positive charge.

Direction of the Dipole Moment Vector: The dipole moment vector points from the center of the negative charge to the center of the positive charge of the charge distribution.

The strength of the dipole, the size of $|p|$, increases with the amount of charge separated, q , and the amount of separation, d , as illustrated below.

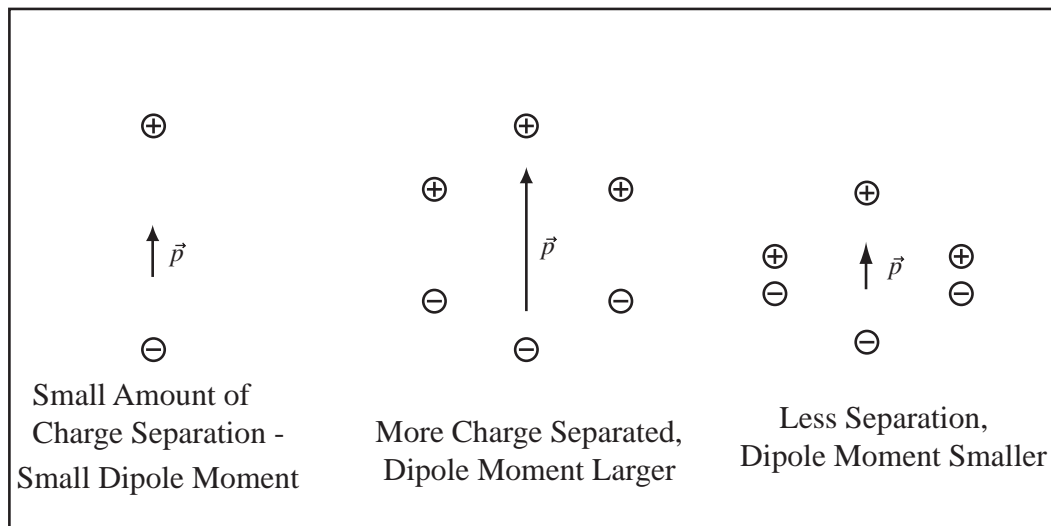

Far from the charges, all charge distributions with zero total charge but non-zero dipole moment have the characteristic dipole electric field. If you see a dipole field, you should be able to draw the dipole moment and tell me that the total charge is zero.

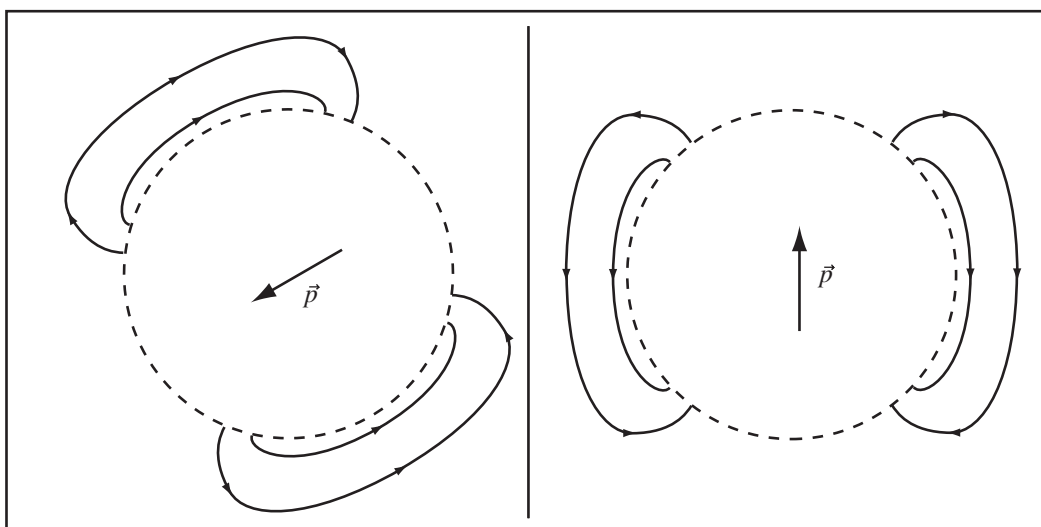

The mathematical form of the electric field for a dipole, far from the dipole, is somewhat complicated. We state it for your reference,

Electric Dipole Field: The electric field of a point dipole at the origin with dipole moment \vec{p} is

$$\vec{E}(\vec{r}) = k \frac{3\hat{r}(\vec{p} \cdot \hat{r}) - \vec{p}}{r^3}.$$

This is the field of a point dipole or the field far from a system with zero charge but non-zero dipole moment.

Simplified Electric Dipole Field: The expression above for the dipole field can be simplified if a direction for the dipole moment is chosen and only the strength of the field along the axes is computed. If $\vec{p} = p\hat{y}$, then along the \hat{y} axis,

$$\vec{E}(0, y, 0) = \frac{2kp\hat{y}}{|y|^3}.$$

and along the x -axis

$$\vec{E}(x, 0, 0) = -\frac{kp\hat{y}}{|x|^3}$$

Notice that the strength of the dipole field falls off as $1/r^3$ whereas the field of a distribution with net charge falls off as $1/r^2$. This is why, far from a distribution with net charge, we see only the radial field of a point charge with the total charge of the distribution.

Example 8.2 Calculating the Dipole Field

Problem: An electric dipole is formed by equal and opposite point charges with charge $\pm 1\text{nC}$ at $\pm 0.2\text{cm}\hat{y}$. The dipole moment points in the $+\hat{y}$ direction. Calculate the field at 5m along the x axis and the y axis.

Solution

(a) Calculate the dipole moment: The dipole moment of a simple two charge dipole is $p = qd$ where $d = 0.4\text{cm}$ is the separation of the charges $p = qd = (1 \times 10^{-9}\text{C})(4 \times 10^{-3}\text{m}) = 4 \times 10^{-12}\text{Cm}$.

(b) Calculate the field along the x -axis: The field point at 5m along the x -axis is far from the charges, so the formula for the long range dipole field can be used

$$\vec{E} = -\frac{kp\hat{y}}{|x|^3} = -\frac{(8.99 \times 10^9 \frac{\text{Nm}^2}{\text{C}^2})(4 \times 10^{-12}\text{Cm})\hat{y}}{|5\text{m}|^3} = -2.88 \times 10^{-4} \frac{\text{N}}{\text{C}}\hat{y}$$

(c) Calculate the field in the y direction: The field point at 5m along the y -axis is far from the charges, so the formula for the long range dipole field can be used

$$\vec{E} = \frac{2kp\hat{y}}{|y|^3} = \frac{2(8.99 \times 10^9 \frac{\text{Nm}^2}{\text{C}^2})(4 \times 10^{-12}\text{Cm})\hat{y}}{|5\text{m}|^3} = 5.75 \times 10^{-4} \frac{\text{N}}{\text{C}}$$

8.2 Drawing Dipole Fields

When drawing a dipole electric field map, we need to use a field at infinity that has a dipole shape. The dipole field will arise naturally from our normal process of drawing electric field maps but for some reason everyone scrunches all the field down very close to the charges. Therefore, to get the correct long range field it helps to draw the dipole field at infinity first. So to draw a dipole field, we use the same process as for a field with net charge (monopole), except replace the long range part with the following two steps:

Determine Direction of Dipole Moment: The dipole moment is directed from the center of negative charge to the center of positive charge. Draw it on your figure.

Draw a Dipole Long Range Field: Draw the circle at infinity and draw a dipole field matching your dipole moment.

Example 8.3 Field of Point Dipole

Problem: Draw the electric field of an electric dipole formed of two point charges with dipole moment in the $+\hat{y}$ direction.

Solution

(a) Draw the Charges: Draw the electric charges at the given locations to scale. Since we are given an electric dipole along the y -axis, draw equal and opposite charges along the y -axis.

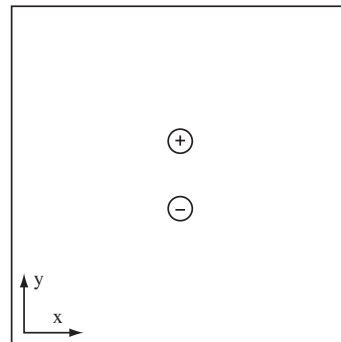

(b) Draw the Dipole Moment: The dipole moment vector is drawn from the center of negative charge to the center of positive charge. For two point charges, the electric dipole is drawn from the negative to the positive charge.

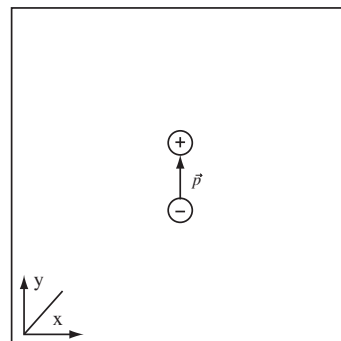

(c) Draw the Long Range Dipole Field: For a charge distribution that has zero net charge and a non-zero dipole moment, the electric field far from the charge has the characteristic shape of an electric dipole.

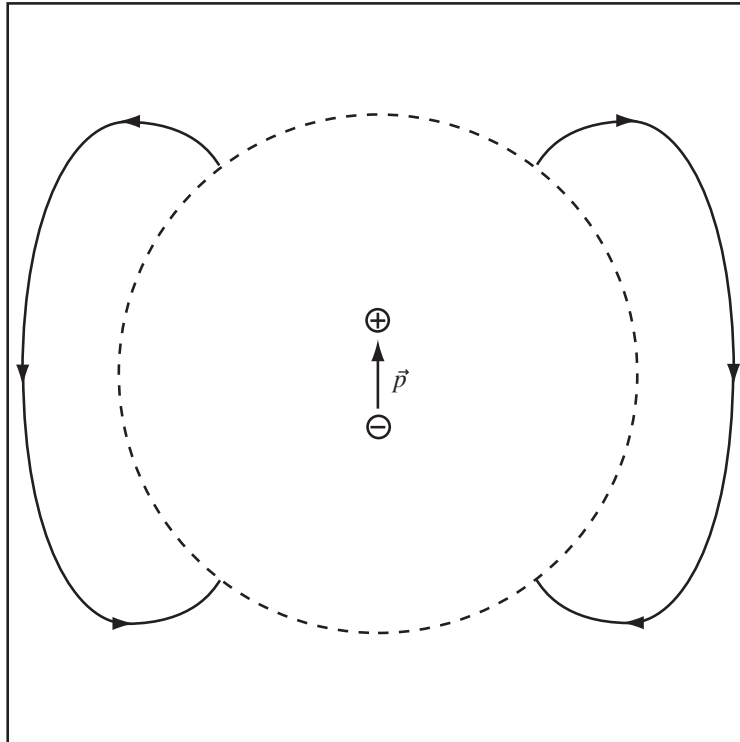

(d) Draw Stubs of Field Lines: I chose eight lines per charge. The field lines exit at the positive charge and enter at the negative.

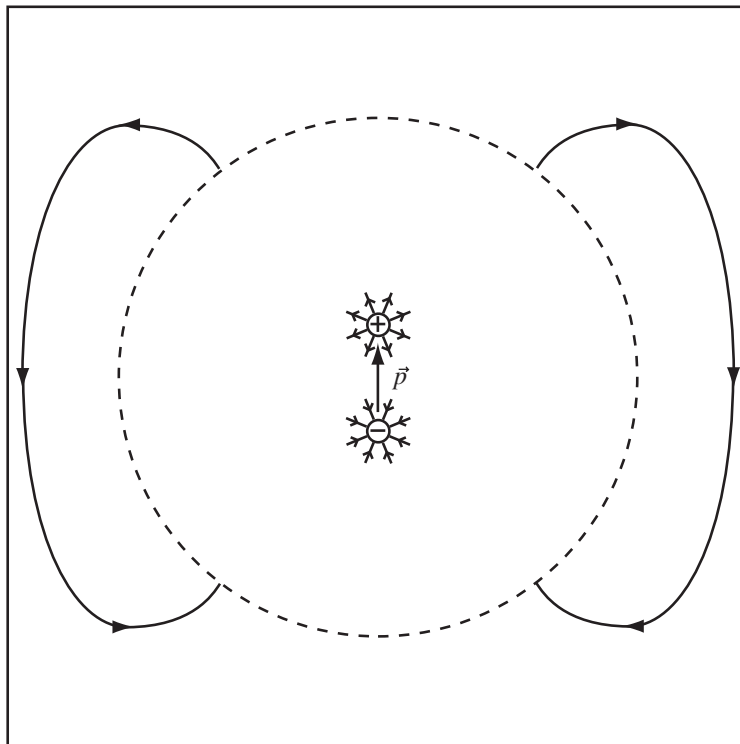

(e) **Connect the Lines:** Connect and smooth the inner and outer lines. Jiggle until you get something appropriately symmetric.

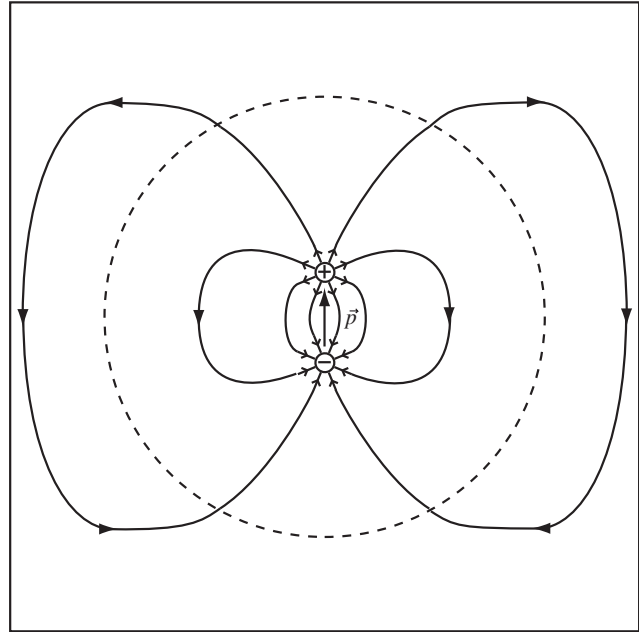

8.3 Qualitative Dipole Behavior

Systems of charge whose lowest order non-zero moment is the dipole moment behave differently than systems of charge with net charge. Our model for an electric dipole will be two equal and opposite charges at each end of a stick.

Barbell Model of Dipole: When considering the motion of dipoles, we will model them using equal and opposite point charges on a stick, as shown to the right.

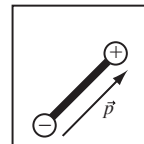

Our barbell dipole is placed in a number of electric fields below. The force on each charge, \vec{F}_+ and \vec{F}_- , and the net force, $\vec{F}_{net} = \vec{F}_+ + \vec{F}_-$, on the dipole is drawn in each case.

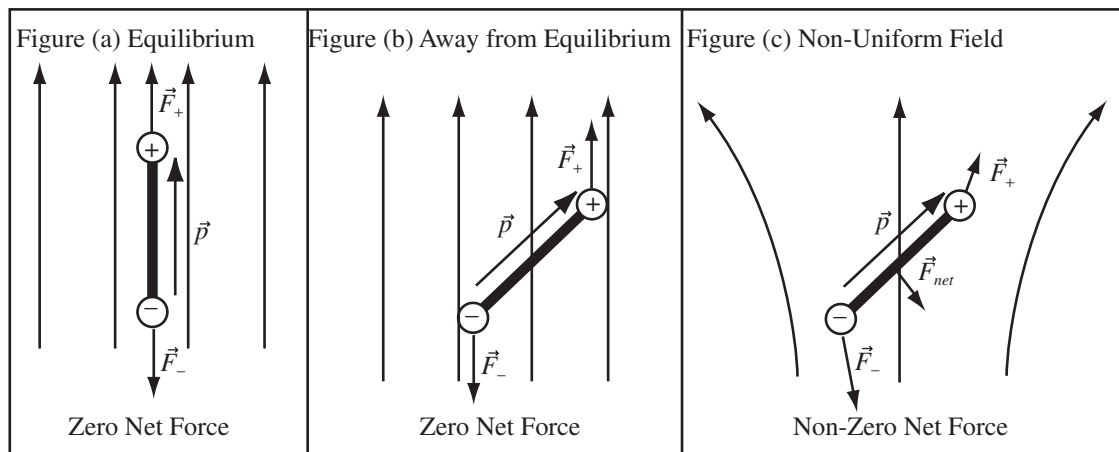

In figure (a) the field is uniform and the dipole moment \vec{p} aligns with the field. The net force is zero and the forces on the dipole do not tend to rotate the dipole. This is the equilibrium position of the dipole. In figure (b), the dipole is rotated away from equilibrium. The net force is still zero, but the force on each charge tends to rotate the dipole toward equilibrium.

Dipoles Rotate to Align with Field: A dipole placed in an electric field is at equilibrium when the dipole moment points in the same direction as the field line. A dipole that is not at equilibrium will tend to rotate toward alignment with the field line.

Dipoles In a Uniform Field Feel Zero Net Force: If a dipole is placed in a uniform electric field, constant through space, then the total force (but not the torque) is zero since the forces on the plus and minus charge are equal and opposite. So the dipole rotates but its center of mass stays in the same place.

In figure (c), the field is not uniform. The positive and negative charges forming the dipole experience forces of different magnitudes and directions and therefore there is a net force on dipole.

Net Force on Dipoles In a Non-Uniform Field: If a dipole is placed in a non-uniform field, the two charges experience difference forces, and the direction of the net force must be determined by adding these forces.

Example 8.4 Electric Dipole in Uniform Field

Problem: A uniform electric field is directed in the $+\hat{x}$ direction. A barbell dipole with dipole moment direction in the $+\hat{y}$ direction is placed in the field.

- Draw the field and the barbell dipole.
- Draw the electric force vectors on the charges at the ends of the dipole.
- Indicate the direction of rotation of the dipole.

Solution to Part (a)

The field lines are evenly spaced since we are told the field is uniform. The dipole moment, in the $+\hat{y}$ direction here, always points from the negative to the positive charge. See figure.

Solution to Part (b)

The force on the positive charge will point the same direction as the field; the force on the negative charge will point in the opposite direction. The forces have the same magnitude since the field is uniform. See figure.

Solution to Part (c)

The dipole will rotate in the clockwise direction based on the forces drawn. The dipole moment will tend to align itself with the field lines.

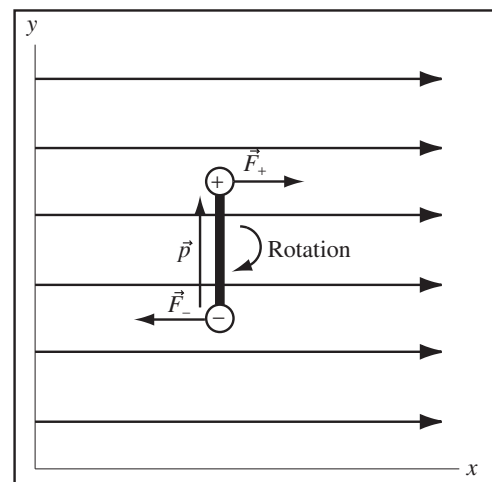

8.4 Dipole Mechanics

We argued in previous section that a dipole will rotate to align with an uniform electric field, but feel no net force. Since the dipole tends to rotate, it must experience a net *torque*. If the field is not uniform, the dipole will experience a net force. This means the force depends on how the field changes. If the dipole is allowed to rotate it will come to equilibrium (if there are losses in the system) with its dipole moment aligned with the field. This behavior implies the dipole is seeking the minimum in some potential energy function. So to quantitatively describe the mechanics of an electric dipole, we need to evaluate the torque, net force, and potential energy.

8.4.1 Potential Energy of a Dipole in an Electric Field

To calculate the potential energy of an electric dipole with orientation θ with respect to a uniform field, we have to calculate the work required to rotate the dipole from the location of zero potential energy to the orientation θ . In figure (a) below, the dipole is drawn in its minimum energy orientation, aligned with the field. In figure (b), the dipole has been rotated an angle θ away from equilibrium. In both figures, the dipole moment vector, \vec{p} , is drawn.

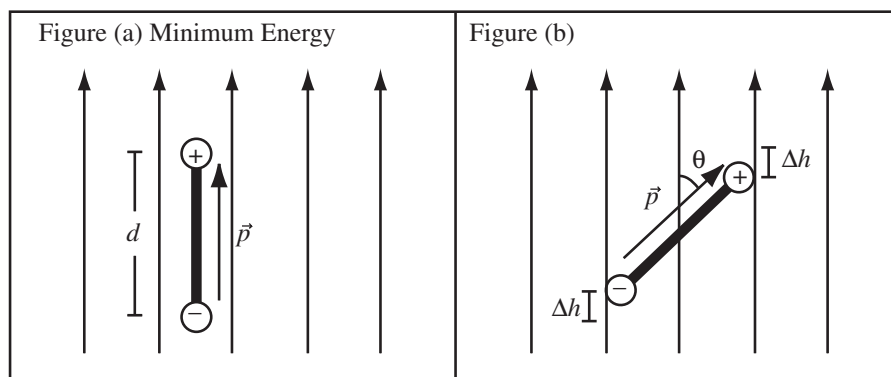

The difference in potential energy, ΔU , from figure (a) to figure (b) is the work, W , an external agent would have to do to rotate the dipole. Work is force times the distance in the direction of the force. Both the positive and negative charge moved a distance Δh against the force of field. The work done is $W = F_+ \Delta h + F_- \Delta h = 2qE \Delta h$, where F_+ is the force on the positive charge, q is the magnitude of the positive charge, and E is the electric field. If θ is the angle between the dipole moment vector, \vec{p} , and the field \vec{E} , and d is the length of the dipole, then $\Delta h = d/2 - d/2 \cos \theta$. Substituting gives the change in potential energy to rotate from figure (a) to figure (b).

$$\Delta U = 2qE \left(\frac{d}{2} - \frac{d}{2} \cos \theta \right) = -pE \cos \theta - pE$$

where I have used $|\vec{p}| = qd$. It is customary to choose the zero of potential energy so the pE goes away.

Potential Energy of an Electric Dipole: The potential energy U of an electric dipole with dipole moment \vec{p} in a uniform electric field \vec{E} is

$$U = -pE \cos \theta = -\vec{p} \cdot \vec{E}$$

where θ is the angle between the dipole moment and the field. The second expression uses the vector dot product, which we will review in Course Guide 11.

8.4.2 Torque on an Electric Dipole

An electric field tends to make an electric dipole rotate, and therefore exerts a torque on the dipole. An electric dipole in a uniform electric field \vec{E} is drawn below. The forces on each charge are also drawn.

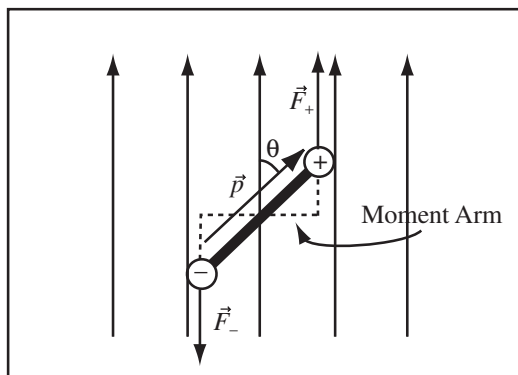

From UPI, the torque τ exerted on the object is the force multiplied by the moment arm, the perpendicular distance to the line of action of the force. The moment arm and lines of action are drawn above. The torque will be calculated about the center of the dipole. The torque on the dipole in the figure causes it to rotate in the counterclockwise direction. Both forces, \vec{F}_+ and \vec{F}_- , exert a torque on the object. The total torque is the sum of the torques of the two forces, $\tau = \tau_+ + \tau_-$. The length of the moment arm is $(d/2) \sin \theta$ for both forces if the separation of the charges is d and the angle θ is measured from the dipole moment to the field. The angle θ is positive above. The force on each charge is qE . The total torque is then $\tau = qEd \sin \theta$ or $\tau = pE \sin \theta$ where I have used $|\vec{p}| = qd$.

Torque on an Electric Dipole: The torque, τ , on an electric dipole with dipole moment vector \vec{p} in an electric field \vec{E} is

$$\tau = pE \sin \theta$$

where θ is measured from \vec{p} to \vec{E} . A positive torque causes a counterclockwise angular acceleration.

When we reach magnetic dipoles and have some experience with the vector cross product, the above expression will be re-written as $\vec{\tau} = \vec{p} \times \vec{E}$.

8.4.3 Force on an Electric Dipole in a Non-Uniform Field

We have already argued that a uniform electric field exerts zero net force on an electric dipole. An electric dipole is drawn below in a non-uniform electric field that points generally in the y direction at the dipole. The force on the charges forming the dipole are drawn as well as the net force, \vec{F}_{net} . The x -component is an artifact of how large I have drawn the dipole. As d , the length of the dipole, gets smaller the x component vanishes.

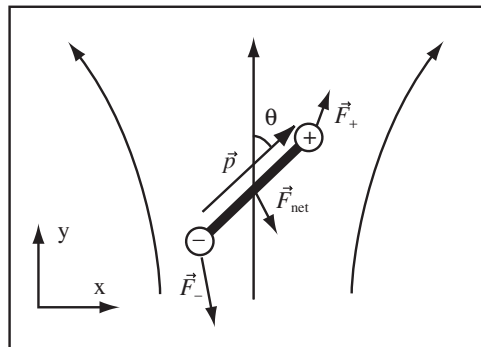

We would like to estimate the force on the dipole in the limit the length of the dipole, d , is small. If the field points generally in the y direction at the location of the dipole then at the dipole we can write the field $\vec{E} = E(y)\hat{y}$. The net force will point generally in the y direction and have magnitude, $F_{net} = qE(y_+) - qE(y_-)$ where y_+ is the location of the $+$ charge and y_- is the location of the $-$ charge. If the separation of charges d is small, then this is approximately

$$F_{net} = q \frac{dE}{dy} (y_+ - y_-) = q \frac{dE}{dy} (d \cos \theta) = p \frac{dE}{dy} (\cos \theta)$$

where θ is the angle between the dipole moment and the field and once again I have use $|\vec{p}| = dq$.

Force on an Electric Dipole in a Non-Uniform Field: The net force on an electric dipole with dipole moment \vec{p} in an electric field that points in the \hat{y} direction, $\vec{E} = E(y)\hat{y}$, is

$$F_{net} = p \frac{dE}{dy} (\cos \theta)$$

where θ is the angle between the dipole moment vector and the y axis.

Note, if the dipole moment aligns with the field ($\theta = 0$), the dipole feels a force toward stronger field. If the dipole anti-aligns with the field ($\theta = 180^\circ$), the dipole feels a force toward weaker field.

Example 8.5 Rotation of a Water Molecule

Problem: The NIST database gives the dipole moment of water as $p = 1.85 \text{ debye} = 6.18 \times 10^{-30} \text{ Cm}$. As you work through these databases the profusion of different systems of units is really annoying. A water molecule is placed in the electric field of the golf tube modelled as an infinite line of charge along the z axis. The golf tube has linear charge density $\lambda = -0.10 \mu\text{C}/\text{m}$. The molecule is 4 cm from the axis of the tube along the x axis. The angle between the dipole moment of the molecule and the electric field is $\theta = 45^\circ$.

- Calculate the potential energy of the molecule.
- Calculate the torque exerted on the molecule by the field.
- Calculate the net force on the molecule.

Solution to Part (a)

The electric field of the golf tube at the water molecule is

$$E = \frac{\lambda}{2\pi\epsilon_0 d} = \frac{-0.1 \times 10^{-6} \text{ C/m}}{2\pi(8.85 \times 10^{-12} \frac{\text{C}^2}{\text{Nm}^2})(0.04 \text{ m})} = -45000 \frac{\text{N}}{\text{C}}$$

The potential energy of an electric dipole in an electric field is

$$U = -pE \cos \theta = -(6.18 \times 10^{-30} \text{ Cm})(-45000) \cos 135^\circ = 2.0 \times 10^{-25} \text{ J}$$

where $\theta = 135^\circ$ is the angle between the dipole and the field. This drawing is way out of scale, a molecule is tiny, so we can pretend E is in the same direction at either end of the dipole.

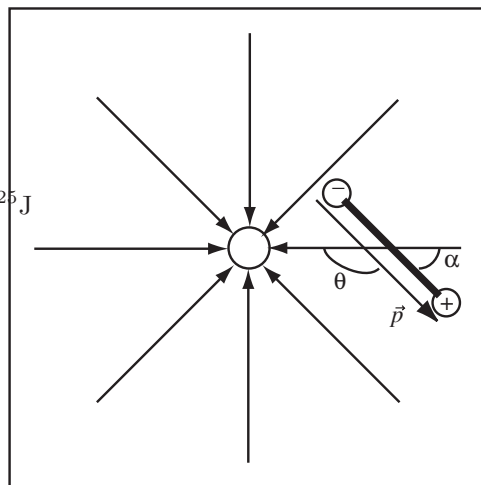

Solution to Part (b)

The magnitude of the torque on the water molecule is

$$|\tau| = pE \sin \alpha = |(6.18 \times 10^{-30} \text{ Cm})(-45000 \frac{\text{N}}{\text{C}}) \sin 45^\circ| = 2.0 \times 10^{-25} \text{ Nm}$$

where α is the angle between the dipole moment and the x axis. Notice that torque and energy have the same units $1 \text{ Joule} = 1 \text{ Nm}$.

Solution to Part (c)

The force on the dipole is

$$F = p \frac{dE}{dr} \cos \theta$$

The derivative of the electric field is

$$\frac{dE}{dr} = \frac{d}{dr} \frac{\lambda}{2\pi\epsilon_0 r} = -\frac{\lambda}{2\pi\epsilon_0 r^2}$$

The force is then

$$F = p \frac{dE}{dr} \cos \theta = -\frac{p\lambda}{2\pi\epsilon_0 r^2} \cos \theta = -\frac{(6.18 \times 10^{-30} \text{Cm})(-0.1 \times 10^{-6} \text{C/m})}{2\pi(8.85 \times 10^{-12} \frac{\text{C}^2}{\text{Nm}^2})(0.04\text{m})^2} \cos 45^\circ = 4.9 \times 10^{-24} \text{N}$$

The positive sign indicates the force is outward from the golf tube.

Chapter 9

Continuous Charges

With Coulomb's Law, $\vec{E} = kq\hat{r}/r^2$, and the Law of Linear Superposition, we can calculate the electric field of any charge distribution. In this chapter we will use the two laws to calculate the electric field of some continuous charge distributions.

9.1 Thinking About Continuous Systems of Charge

A continuous charge distribution contains electric charge spread out through space. The distribution may be a linear charge density spread on a curve, a surface charge density spread on a surface, or a volume charge density spread throughout a volume. To calculate the field of any distribution, divide it into smaller chunks that can be approximated as point charges, calculate the field of each chunk at the desired point, and add using linear superposition.

Consider a linear charge density $\lambda(s)$ spread along the curve drawn below. The variable s measures the distance along the curve from one end of the curve.

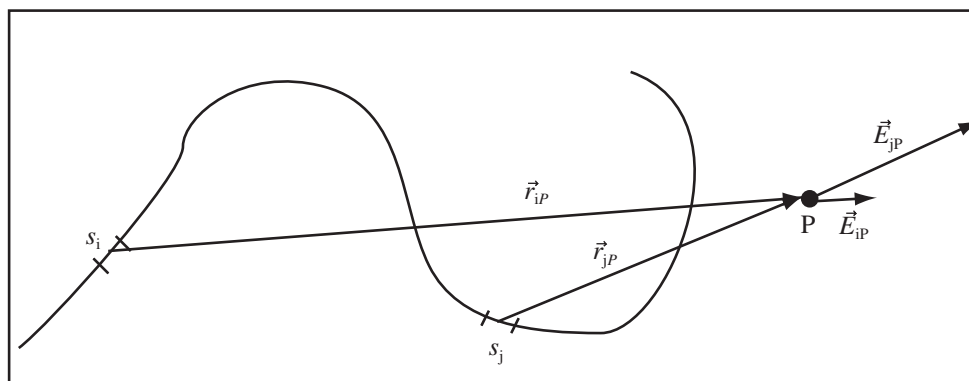

If calculus did not exist, what has to be done to calculate the field is pretty obvious, cut the curve into small bits of length Δs , calculate the field of each bit, and add using linear superposition. Let the i th bit be at the location s_i along the curve and contribute a field \vec{E}_{iP} at the point P . The contributions of the i th and j th segment are drawn above. The charge of each piece is the charge density multiplied by the length of the piece, $q_i = \lambda(s_i)\Delta s$. The total electric field is the sum of the fields of each piece,

$$\vec{E}_P = \sum_i \frac{kq_i}{r_{iP}^2} \hat{r}_{iP} = \sum_i \frac{k\lambda(s_i)\Delta s}{r_{iP}^2} \hat{r}_{iP}$$

This expression could be summed directly on a computer to any accuracy or converted to an integral using

$$s_i \Rightarrow s \quad \Delta s \Rightarrow ds \quad \hat{r}_{iP} \Rightarrow \hat{r}_P(s) \quad r_{iP} \Rightarrow r_P(s)$$

where now both the distance and the unit vector are functions of the length along the curve.

$$\vec{E}_P = \int \frac{k\lambda(s)ds}{r_P(s)^2} \hat{r}_P(s)$$

To me, the sum looks easy and the integral looks horrible, even though they are exactly the same thing. This is why I stress thinking in terms of the sum first.

The same process can be carried out for charge spread over a surface. Suppose a surface occupies part of the x - y plane. The surface is covered with a surface charge density $\sigma(x, y)$. We wish to calculate the electric field at a point P at the point \vec{r}_P . Imagine dividing the surface into small squares of width Δx and height Δy . Let the center of each square be $\vec{r}_{ij} = (x_i, y_j, 0)$. The displacement vector from one of the squares to point P is $\vec{r}_{ijP} = \vec{r}_P - \vec{r}_{ij}$. The charge of each square is $q_{ij} = \sigma(x_i, y_j)\Delta x\Delta y$. The electric field of the surface at point P is

$$\vec{E}_P = \sum_i \sum_j \frac{kq_{ij}}{r_{ijP}^2} \hat{r}_{ijP} = \sum_i \sum_j \frac{k\sigma(x_i, y_j)\Delta x\Delta y}{r_{ijP}^2} \hat{r}_{ijP}$$

Those of you who have had Cal III should see the two dimensional integral. A similar expression can be written for the volume charge distribution.

9.2 One Dimensional Problems

Let's begin calculating the electric field of continuous systems with a couple one-dimensional systems. We'll restrict ourselves to lines and circles. This section presents two examples of calculating the electric field of a charge distribution where the charge is spread out over a line in space. In the first example the charge density is constant (uniform). In the second example, the charge density changes from point to point along the line. Before beginning, our calculations will be simplified if we substitute the definition of the unit vector, $\hat{r} = \vec{r}/r$, into Coulomb's law.

Alternate Form of Coulomb's Law: The electric field at point P due to a point charge q at location \vec{r}_i is

$$\vec{E}_P = \frac{kq}{r_{iP}^2} \hat{r}_{iP} = \frac{kq}{r_{iP}^3} \vec{r}_{iP}$$

where $\vec{r}_{iP} = \vec{r}_P - \vec{r}_i$ is the displacement vector from the point i to the point P .

Example 9.1 Field of Line Charge along Line

Problem: A finite line charge lies along the x -axis with its center at the origin. It has a uniform linear charge density λ . The line charge has length $2L$ as drawn to the right.

- Calculate the electric field at a point $R > L$ along the x -axis. This will be a formula not a number.
- Use your formula to calculate the electric field at $R = 2L$.
- Compare the field in (b) to the field you would get if you approximated the line charge by a point charge at the origin with charge $2\lambda L$ the total charge of the line charge.

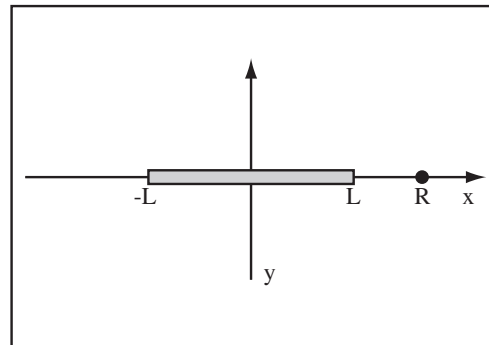

Solution to Part (a)

(a) Divide the Line Charge into Segments: Cut the line charge up into segments of length Δx and center x_i as drawn to the right. The field points in the \hat{x} direction at R , so we just have to calculate the magnitude of the electric field of each segment, $E_i = kq_i/d_i^2$, where d_i is the distance from the center of the segment to the point R . Observing the diagram to the right, $d_i = R - x_i$. The charge of the segment is $\lambda\Delta x$. So using linear superposition,

$$E(R) = \sum_i \frac{kq_i}{d_i^2} = \sum_i \frac{k\lambda\Delta x}{(R - x_i)^2}$$

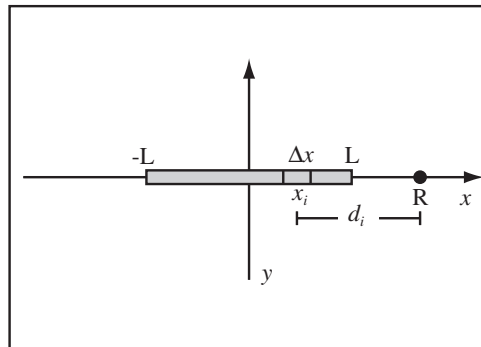

(b) Convert Sum into Integral and Do the Integral: Let the segments become infinitely small, so $\Delta x \rightarrow dx$, $x_i \rightarrow x$, and $\sum_i \rightarrow \int_{-L}^L$

$$E(R) = k\lambda \int_{-L}^L \frac{dx}{(R - x)^2}$$

Use the u - substitution, $u = R - x$, so $du = -dx$,

$$E(R) = -k\lambda \int_{R+L}^{R-L} \frac{du}{u^2}$$

This is an integral of the form, $\int r^n dr = \frac{r^{n+1}}{n+1} + C$ with $n = -2$, so $\int r^{-2} dr = -\frac{1}{r} + C$.

$$E(R) = k\lambda \left(\frac{1}{u} \right) \Big|_{R+L}^{R-L} = k\lambda \left(\frac{1}{R-L} - \frac{1}{R+L} \right)$$

If you got here, you would get full credit on homework or an exam. I'm going to simplify a bit,

$$E(R) = k\lambda \left(\frac{R+L}{(R-L)(R+L)} - \frac{R-L}{(R+L)(R-L)} \right) = k\lambda \left(\frac{R+L - (R-L)}{(R^2 - L^2)} \right) = \frac{2kL\lambda}{(R^2 - L^2)}$$

Note, we get the field of a point charge if $R \rightarrow \infty$, $E(R) \rightarrow 2kL\lambda/R^2 = kQ/R^2$. Be sure to put the vector back in at the end, $\vec{E} = E(R)\hat{x}$.

Solution to Part (b)

Just substitute $R = 2L$ into the formula,

$$E(2L) = \frac{2kL\lambda}{(2L)^2 - L^2} = \frac{2k\lambda}{3L}$$

The units look wrong here, but λ has units is C/m not C.

Solution to Part (c)

A point charge of charge $Q = 2\lambda L$ produces an electric field

$$E(2L) = \frac{kQ}{R^2} = \frac{k(2\lambda L)}{(2L)^2} = \frac{1k\lambda}{2L}$$

So in this case we would make a substantial error by approximating the finite line charge as a point charge. This approximation gets better as we get farther from the charge.

Example 9.2 Field of a Variable Line of Charge

Problem: A line of charge with linear charge density $\lambda(x) = \gamma x$, where γ is a constant, lies along the x axis from 0 to L . Calculate the electric field at a point a distance R along the positive y axis.

Solution

(a) Divide the System into Segments: Imagine dividing the system into segments of length Δx . The i th segment is drawn to the right. The electric field of the i segment is given by Coulomb's law

$$\vec{E}_{iP} = \frac{kq_i}{r_{iP}^3} \vec{r}_{iP}$$

So we need q_i , \vec{r}_{iP} and r_{iP} .

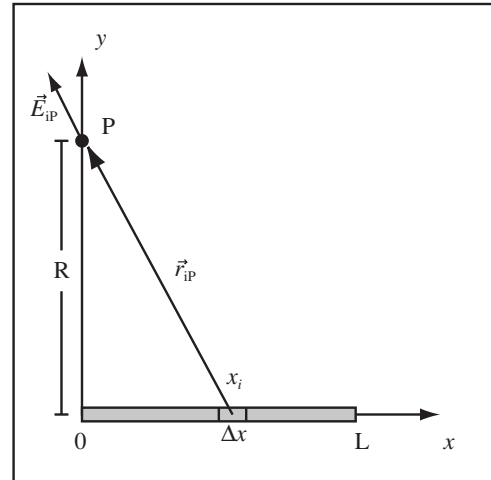

(b) Calculate the charge of the i th segment: The charge, q_i , is the length of the segment multiplied by the charge density, $q_i = \lambda(x_i)\Delta x = \gamma x_i \Delta x$.

(c) Calculate the Displacement Vector: The displacement vector is by definition, $\vec{r}_{iP} = \vec{r}_P - \vec{r}_i$. The position of the point P is $\vec{r}_P = (0, R, 0)$. The position of the segment i is $\vec{r}_i = (x_i, 0, 0)$, so the displacement vector is $\vec{r}_{iP} = (-x_i, R, 0)$, which is consistent with our drawing.

(d) Calculate the length of the displacement vector: The length of \vec{r}_{iP} is $r_{iP} = \sqrt{x_i^2 + R^2}$.

(e) Use Linear Superposition: The total electric field at point P is the sum of the fields of all the segments

$$\vec{E}_P = \sum_i \frac{kq_i}{r_{iP}^3} \vec{r}_{iP} = \sum_i \frac{k\gamma x_i \Delta x}{(x_i^2 + R^2)^{\frac{3}{2}}} (-x_i, R, 0)$$

(f) Convert the Sum to an Integral: Let $\Delta x \Rightarrow dx$, $x_i \Rightarrow x$, and $\sum_i \Rightarrow \int_0^L$,

$$\begin{aligned} \vec{E}_P &= \sum_i \frac{k\gamma x_i \Delta x}{(x_i^2 + R^2)^{\frac{3}{2}}} (-x_i, R, 0) \\ &= \int_0^L \frac{k\gamma x dx}{(x^2 + R^2)^{\frac{3}{2}}} (-x, R, 0) \end{aligned}$$

This is actually three integrals, one each for the x , y , and z component.

$$\vec{E}_P = \left(-\int_0^L \frac{k\gamma x^2 dx}{(x^2 + R^2)^{\frac{3}{2}}}, \int_0^L \frac{k\gamma x R dx}{(x^2 + R^2)^{\frac{3}{2}}}, 0 \right)$$

At this point the physics is done.

(g) Separate into Components: Since we are calculating an electric field, we need values for the x , y , and z components of the field. $\vec{E}_P = (E_{Px}, E_{Py}, E_{Pz})$. The z component is zero, so we need

$$E_{Px} = -k\gamma \int_0^L \frac{x^2 dx}{(x^2 + R^2)^{\frac{3}{2}}}$$

and

$$E_{Py} = k\gamma R \int_0^L \frac{x dx}{(x^2 + R^2)^{\frac{3}{2}}}$$

(h) Try Calculus: I typed $x/(x^2 + R^2)^{(3/2)}$ into integrals.com and it told me

$$\int \frac{x dx}{(x^2 + R^2)^{\frac{3}{2}}} = -\frac{1}{\sqrt{x^2 + R^2}} + C$$

I typed $x^2/(x^2 + R^2)^{3/2}$ into integrals.com and it told me

$$\int \frac{x^2 dx}{(x^2 + R^2)^{3/2}} = -\frac{x}{\sqrt{x^2 + R^2}} + \ln(x + \sqrt{x^2 + R^2}) + C$$

where C is the constant of integration. The Log reported at the web site is actually the natural logarithm, which we will denote as \ln .

(i) Use the integrals: Substituting the limits 0 and L ,

$$E_{Px} = -k\gamma \int_0^L \frac{x^2 dx}{(x^2 + R^2)^{3/2}} = -k\gamma \left(-\frac{x}{\sqrt{x^2 + R^2}} + \ln(x + \sqrt{x^2 + R^2}) \right) \Big|_0^L$$

$$E_{Px} = -k\gamma \left(-\frac{L}{\sqrt{L^2 + R^2}} + \ln(L + \sqrt{L^2 + R^2}) - \ln(R) \right)$$

$$E_{Py} = k\gamma R \int_0^L \frac{x dx}{(x^2 + R^2)^{3/2}} = k\gamma R \left(-\frac{1}{\sqrt{x^2 + R^2}} \right) \Big|_0^L$$

$$E_{Py} = k\gamma R \left(-\frac{1}{\sqrt{L^2 + R^2}} + \frac{1}{R} \right)$$

Chapter 10

Symmetry

10.1 High Symmetry Systems

In Course Guide 7, we learned to draw the electric field map for collections of point charges and for some continuous charge distributions. Those field maps had to have the same symmetry as the system of charge. Symmetry is a very important idea in physics because if a system has a certain symmetry, the physical description of the system must also have that symmetry. In this chapter, we will examine systems where the symmetry allows us to guess the shape of the field.

Symmetry: A symmetry of a system is a transformation of the system which leaves the system unchanged. For example, in some of our field maps if the charges were reflected through a plane the same system of charge resulted.

- Planar Symmetry—The system is unchanged if it is moved (translated) in a plane. We will work with infinite planes that have uniform surface charge and infinite slabs of charge that have uniform volume charge density.

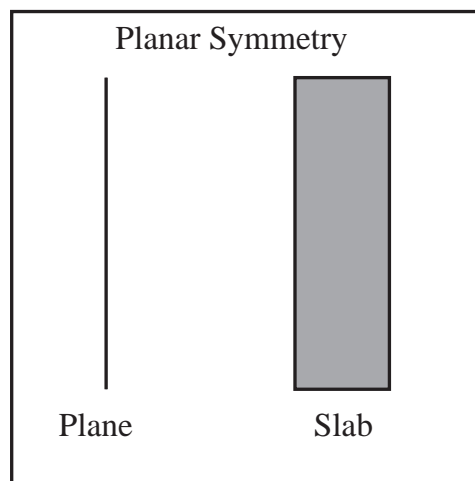

- Cylindrical Symmetry—A system with cylindrical symmetry is unchanged when it is rotated about its axis or translated down its axis. We will build systems of cylindrical symmetry out of infinitely long straight lines of charge; thin, infinitely long cylindrical shells with uniform surface charge; infinitely long tubes of charge with uniform volume charge density; and infinitely long thick cylindrical shells with uniform volume charge density.

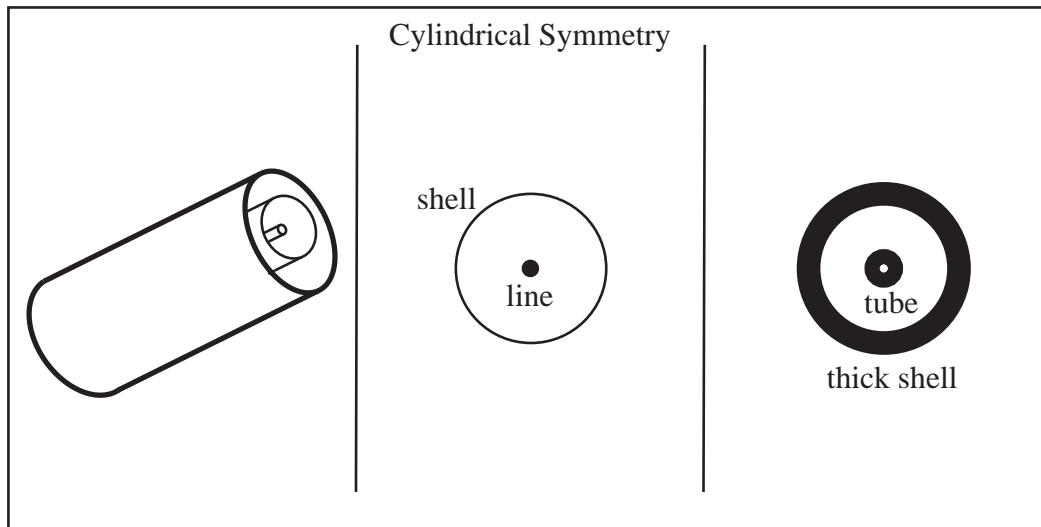

- Spherical Symmetry—A system with spherical symmetry is left unchanged by any rotation about its center. We will build spherically symmetric systems of charge out of concentric point charges, thin spherical shells of charge with uniform surface charge density, and spherical volumes of charge as well as thick spherical shells with uniform volume charge density.

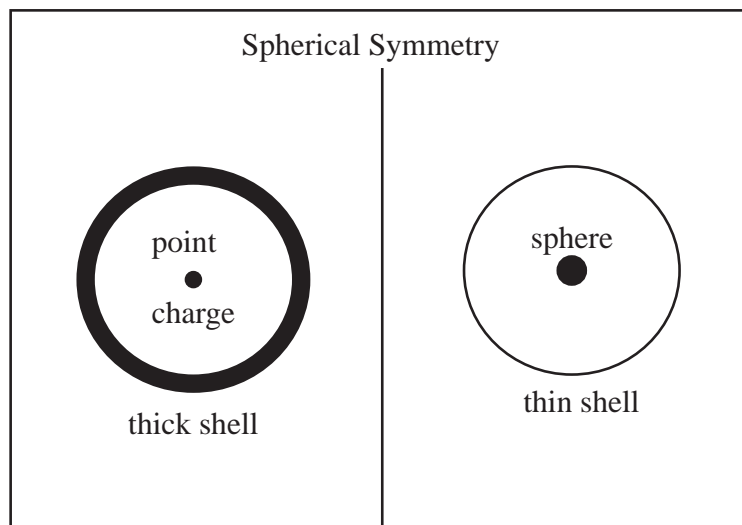

10.2 The Shape of a High Symmetry Field

A spherical system of charge is unchanged if it is rotated through any angle about its center, therefore the field of a spherical system must be unchanged if rotated through any angle about the center of the system. A little experimentation will convince you that this means the field must point straight outward from the center or inward toward the center of the system, that is the field is radial. For a system with cylindrical symmetry the same reasoning will convince you that the field points radially outward from or inward to the axis of the system. Unfortunately, since we draw in two dimensions our spherical and cylindrical field maps look the same. Examples of the fields of various cylindrical and spherical distributions of charge are shown below.

Field of Point Charge or Line Charge: Graphically, since we represent the line charge in two-dimensions, a point charge and a line charge look the same with lines radiating out from a dot. The big difference is that for a line charge this is a true representation of a cross-sectional slice of the field. For a point charge, the number of lines in all three dimensions is proportional to the total charge so we have laid all these lines out flat.

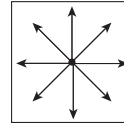

Field of Shell of Charge: A spherical or cylindrical shell of charge has only field lines outside the shell, since a surface inside the shell encloses zero charge.

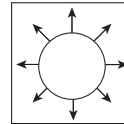

Volume of Charge: A uniform volume of charge has field lines starting all through it. Note at the right the field lines begin throughout the volume.

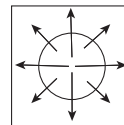

A system with planar symmetry is unchanged if translated along the plane, rotated, and for a single plane reflected about its center. This means that the field lines must point directly outward from or inward to the plane. The electric field of the plane does not change with the distance from the plane, which means far from a planar charge distribution the field is that of a single plane with the total charge density of the system. A single plane may be reflected without changing the system, so the field far from the planar system must be equal and opposite.

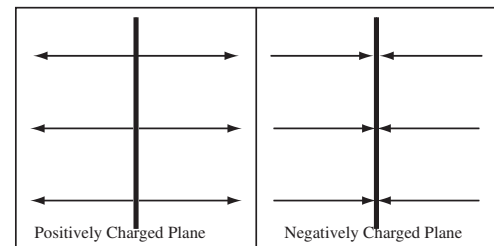

The Far Field of Planar System is Equal and Opposite: For the planar system to the right, the electric field in region I must be equal and opposite the field in region IV, or more generally the field in the outermost regions are equal and opposite.

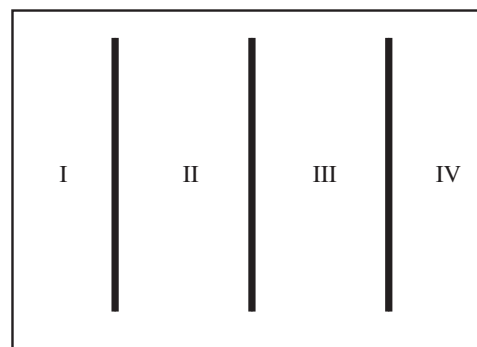

10.3 Drawing Spherical and Cylindrical Systems

Drawing the field map is an important part of understanding a system of charge, a good check on the calculation, and will be a crucial part of the solution process when conductors and dielectrics are introduced into the mix. The most intuitive highly symmetric system is the spherical system. It is somewhat easier than the planar system because there is a natural starting point, the center of the distribution. To draw the map, we use symmetry to deduce the shape of the field and Gauss' law Version 0 to determine how many field lines to draw. Gauss' law will be applied to some carefully chosen surfaces, which we will call *Gaussian surfaces*.

Example 10.1 Drawing Electric Field Map Spherical Symmetry

Problem: Draw the electric field map of a $-1\mu\text{C}$ point charge surrounded by a spherical shell of charge with surface density $\sigma = 130\frac{\mu\text{C}}{\text{m}^2}$ and radius 5cm concentric with the point charge.

Solution

(a) Compute the Total Charge of Each Object: The total charge of the point charge is given as $q_{\text{point}} = -1\mu\text{C}$. The total charge of the shell is

$$q_{\text{shell}} = 4\pi r_{\text{shell}}^2 \sigma = 4\pi(0.05\text{m})^2(130\mu\text{C}/\text{m}^2) = 4\mu\text{C}.$$

(b) Select a Number of Lines per Charge: Gauss' Law states that the number of field lines exiting a region is proportional to the total charge inside the region. The first step in drawing a continuous field map is the same as the first step of drawing the field map for a system of point charges, select a number of lines per charge. I select 4 lines per $1\mu\text{C}$.

(c) Draw the System of Charges: A *shell* is a very thin sheet of charge. Label a set of regions where Gaussian surfaces in different regions enclose different amounts of charge. Use Roman numerals to label the regions. There are two regions in this problem: inside the shell and outside the shell. It often helps to label areas with no charge "Air".

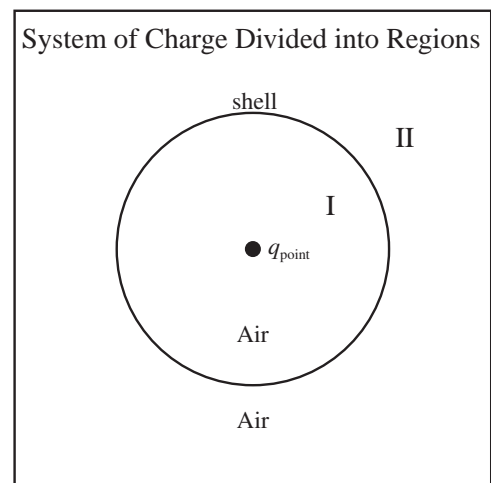

(d) Apply Gauss' Law to Region I: Apply Gauss' law to the spherical surface drawn in region I. By Gauss' Law, the charge enclosed by a Gaussian surface in region I is proportional to the field lines exiting the surface. In region I, a Gaussian surface encloses only the point charge with charge $-1\mu\text{C} = 4$ lines going inward. The direction of the lines is determined by the sign of the net charge. Draw four lines going inward in region I. I have tried to make the Gaussian surface appear spherical, but I will usually just draw a circle.

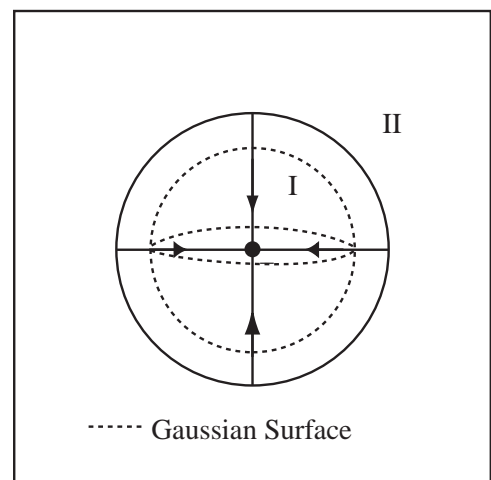

(e) Apply Gauss' Law to Region II: Continue to work out from the center. Apply Gauss' Law in region *II*. The total charge enclosed by a Gaussian surface in region *II* is $q_{point} + q_{shell} = -1\mu\text{C} + 4\mu\text{C} = 3\mu\text{C}$. If 4 lines exit a Gaussian surface for each $1\mu\text{C}$, then 12 lines exit a Gaussian surface containing $3\mu\text{C}$. Draw the 12 lines exiting the charged shell through the charged surface. A quick check shows that the shell has 12 lines leaving on the outside and four lines leaving on the inside, for a total of 16 lines leaving the object. Since it has a total charge of $4\mu\text{C}$ this had better be the case if we did it right!

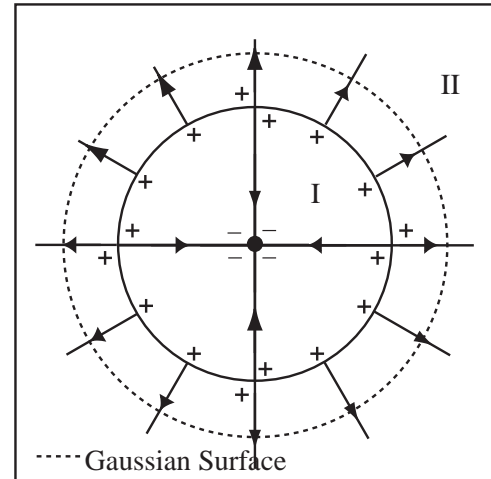

(f) Draw the charges: Draw positive charges where lines begin and negative charge where lines end. If all went well you drew a number of charges proportional to the total charge of the object. The charges are drawn above. Note there are 16 + charges drawn which is correct for $4\mu\text{C}$.

Drawing a field map for cylindrically symmetric distributions of charge is the same as for spherical distributions except that, rather than allocating field lines based on total charge, field lines are allocated based on charge per unit length.

10.4 Drawing Planar Systems

One can also draw the field maps of systems with planar symmetry by using Gauss' law Version 0 on a cylindrical Gaussian surface. Next chapter, we will learn to calculate the fields for planar systems. We will simply draw the field maps for the planar systems with line densities proportional to the computed strengths.

Chapter 11

Gauss' Law

In this chapter, we learn how to calculate the electric field of the infinite line and infinite plane of charge using Gauss' Law. Course Guide 7 and Course Guide 10 applied Gauss' law qualitatively, now its time to do the math.

11.1 Electric Flux

To turn the qualitative expression of Gauss' law (Version 0) into a quantitative expression appropriate for calculations, a mathematical analog for a field line must be found. This will involve manipulation of the vector operation, the dot product, and a new physical quantity, the electric flux.

11.1.1 Working with Dot Products

A dot product is a vector operation which takes two vectors and yields a number. Some intuition about the dot product is helpful in the understanding of Gauss' Law. We can define the dot product in two equivalent forms:

Definition of Dot Product: The expression $\vec{A} \cdot \vec{B}$ is a dot product and is defined as:

$$\vec{A} \cdot \vec{B} = A_x B_x + A_y B_y + A_z B_z.$$

Angle Form of Dot Product: The dot product $\vec{A} \cdot \vec{B}$ can also be computed as:

$$\vec{A} \cdot \vec{B} = |A||B| \cos(\theta),$$

where θ is the angle from \vec{A} to \vec{B} .

The angle form of the dot product allows easy computation of two important special cases, parallel vectors and perpendicular vectors. If two vectors are perpendicular, the angle between the vectors is 90° , $\cos 90^\circ = 0$, so the dot product is zero. If two vectors are parallel, that is if they point in the same direction, the angle between the vectors is zero, $\cos 0 = 1$, giving $\vec{A} \cdot \vec{B} = AB$. If one of the vectors is a unit vector, which by definition has length 1, $\vec{A} \cdot \hat{B} = A$. If the vectors are anti-parallel, point in opposite directions, then $\vec{A} \cdot \vec{B} = -AB$

Using the Dot Product to Take the Projection of a Vector: If one of the vectors in a dot product is a unit vector, then the dot product returns the length of the vector in the direction of the unit vector. The figure to the right illustrates this for the dot product $C = \vec{A} \cdot \hat{B}$.

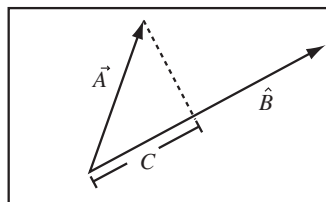

11.1.2 Definition of Electric Flux

The mathematical quantity which replaces the geometric field line in Gauss' Law is called the *electric flux*. The symbol for electric flux is ϕ_e where the Greek symbol is pronounced "fi", like fe fi fo fum. The electric flux through a surface is qualitatively the amount the electric field points straight through the surface multiplied by the area of the surface.

Electric Flux of a Flat Surface in a Uniform Field: The electric flux through a flat surface with surface area A in a uniform electric field E is

$$\phi_e = EA \cos \theta$$

where θ is the angle between the electric field and the normal to the surface.

Definition Surface Normal:

A surface normal is a vector which points straight out from the surface; a vector that is perpendicular to the surface. A surface has two sides and a normal vector for each side at every point on the surface. The symbol \hat{n} is used to denote the normal to the surface.

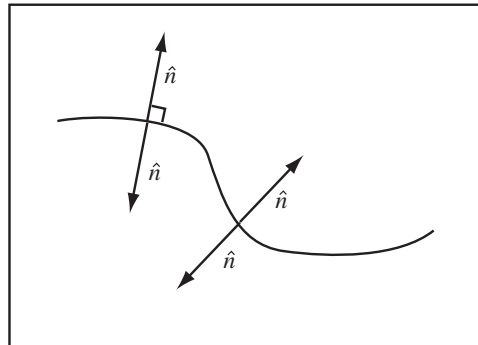

Normals of Simple Surfaces: A sphere, centered at the origin, has outward surface normal \hat{r} where the radius vector $\vec{r} = (x, y, z)$. A cylinder centered on the z axis has outward surface normal \hat{r} where $\vec{r} = (x, y, 0)$. A surface in the $x - y$ plane has two surface normals, \hat{z} and $-\hat{z}$.

The electric flux through a surface is proportional to the number of field lines crossing the surface. Let's examine a flat surface in a uniform field. A side view of a square loop is shown below. As you can see, the number of field lines passing through the surface depends on the area of the surface and the angle the surface makes with the field.

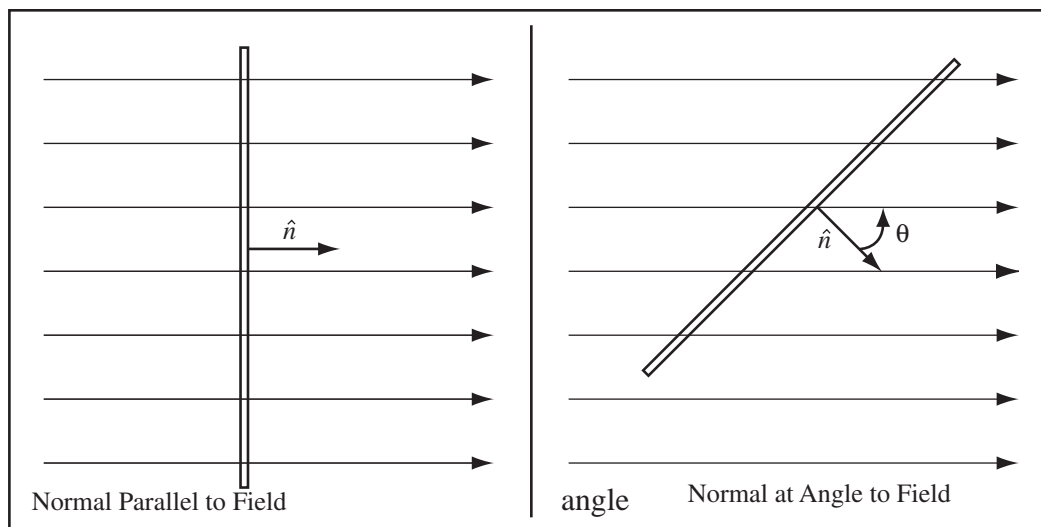

Example 11.1 Flux through Hoop in Earth's Field

Problem: The Earth has an electric field of 150N/C downward. A hula-hoop (a ring of radius 0.5m) lies on the ground. What is the magnitude of the electric flux through it?

Solution

Since the field is parallel to the normal of the hoop, the flux is $\phi_e = |\vec{E}|A$. The area of the hoop is $A = \pi r^2$,

$$\phi_e = |\vec{E}|\pi r^2 = 150 \frac{\text{N}}{\text{C}} \pi (0.5\text{m})^2 = 117.8 \frac{\text{N}}{\text{C}} \text{m}^2.$$

The electric flux can be defined for surfaces that aren't flat and fields that aren't uniform.

Definition Electric Flux: The electric flux, ϕ_e , through a surface S is defined as

$$\phi_e = \int_S (\vec{E} \cdot \hat{n}) dA,$$

where \hat{n} is the outward normal to the surface and dA is an element of area of the surface.

If the electric field is uniform and the surface is flat, the electric flux can be re-written

$$\phi_e = \int_S (\vec{E} \cdot \hat{n}) dA = (\vec{E} \cdot \hat{n}) \int_S dA = (\vec{E} \cdot \hat{n}) A$$

where A is the area of the surface. Using the properties of the dot product, we can re-write this as

$$\phi_e = |\vec{E}| |\hat{n}| A \cos \theta = EA \cos \theta$$

since $|\hat{n}| = 1$. The angle θ is the angle between the surface normal and the electric field. Therefore, we recover our definition of electric flux for a flat loop.

11.1.3 Qualitative Meaning of Flux

The word flux in common usage implies flow or movement. We say things are "in flux". The math underlying Gauss' law is used for virtually every flow process: water flow, air flow, heat flow, and quantum probability flow. To understand flux, it helps to think of it in terms of a fictitious flow of the electric field. To most people, the clearest picture of flux comes when they consider rain drops falling into a bucket. Define the flow of raindrops as

$$F = \frac{\text{number of drops}}{\text{Area} \cdot \text{time}}$$

We want to use this flow to predict how much rain per unit time falls in a bucket with a square top with dimensions ℓ . The area of the top of the bucket is $A = \ell^2$. Naturally, we consider a drop to be in the bucket if it crosses the plane formed by the top of the bucket (the surface bounded by the curve formed by the edges of the top of the bucket). I have drawn rain falling vertically downward and a bucket in various orientations below. I have also drawn the top view of the bucket, what an observer looking directly down from the top would see.

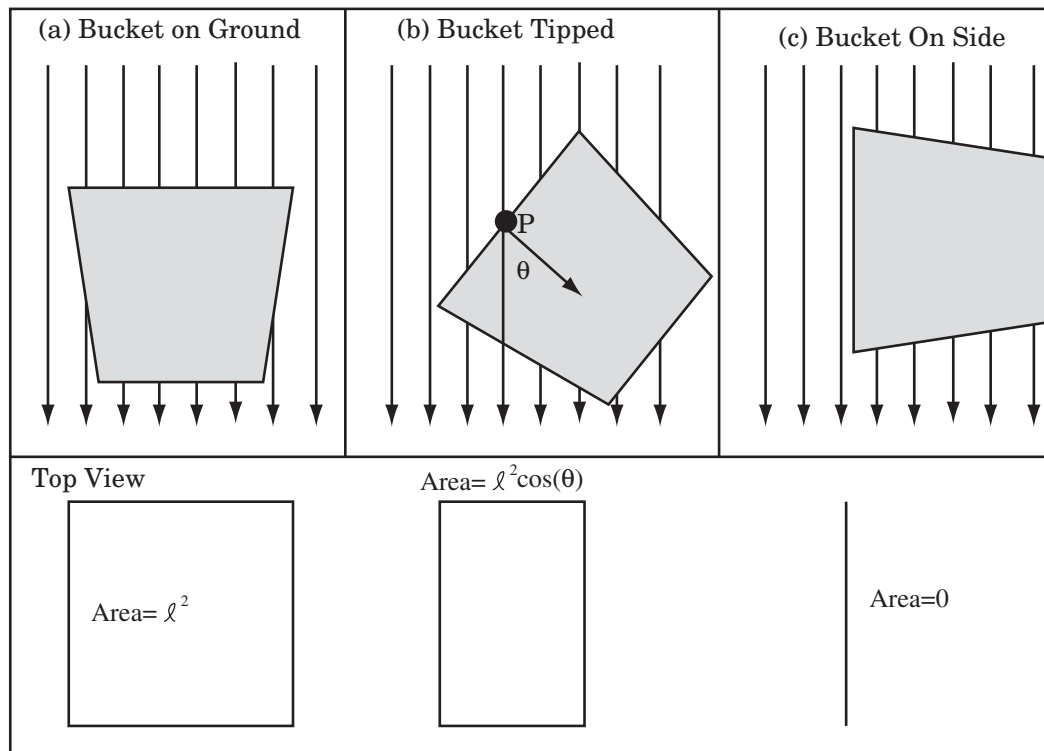

The rain drops per unit time falling into the bucket, the flux of drops through the surface bounded by the top of the bucket, is proportional to the area of the top of the bucket projected on the ground. In figure (a), the area projected on the ground is $A = l^2$ and the drops per unit time entering the bucket is FA . In figure (b), the bucket is tipped and the projected area is $l^2 \cos \theta = A \cos \theta$, and the drops per unit time entering the bucket is $FA \cos \theta$. In figure (c), the projected area is zero and no drops enter the bucket. If θ is the angle the normal to the surface bounded by the top of the bucket makes with the direction of the falling drops then all three cases can be written $FA \cos \theta$. If electric field replaces the flow of raindrops, then the flux of electric field into the bucket would be $EA \cos \theta$, exactly the mathematical expression for flux in a uniform field.

11.1.4 What is a Surface Integral?

Time to think like a physicist, not a mathematician. The electric flux involves a surface integral. We will never actually do the integral, but what is it really? Let's take a surface immersed in an electric field. The electric field has a magnitude and direction at every point on the surface. There is also a surface normal \hat{n} at each point on the surface. The surface integral chops the surface into tiny squares with area $A_{ij} = \Delta x_i \Delta y_j$. For each square, it multiplies the area by the value of $\vec{E} \cdot \hat{n}$ at the center of the square and then sums it all up.

$$\int_S (\vec{E} \cdot \hat{n}) dA \Rightarrow \sum_{ij} (\vec{E} \cdot \hat{n}) \Delta x_i \Delta y_j$$

Anytime you are dealing with an integral you can't quite visualize, imagining doing it as a sum over small chunks.

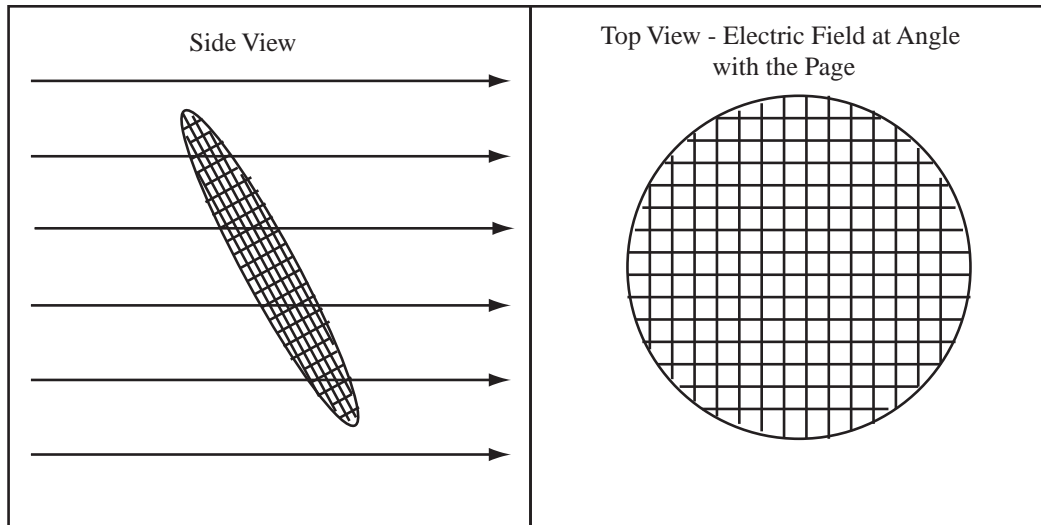

11.2 Gauss' Law

It is finally time to write down the full mathematical form of Gauss' Law. In the mathematical form of Gauss' Law, the field line is replaced by electric flux, ϕ_e . Gauss' Law (Version 0) stated that the charge enclosed in any surface was proportional to the number of field lines leaving the surface, $Q \propto \text{lines}$. If we replace field lines with flux, then $Q \propto \phi_e$. All we need now is the proportionality constant.

Gauss' Law: The electric flux outward through a closed surface is proportional to the charge enclosed, Q_{enclosed} , by the surface.

$$\phi_e = \int_S (\vec{E} \cdot \hat{n}) dA = \frac{Q_{\text{enclosed}}}{\epsilon_0}$$

The proportionality constant is $\epsilon_0 = 8.85 \times 10^{-12} \text{C}^2/\text{Nm}^2$ and pronounced "epsilon naught". The constant, ϵ_0 , is a fundamental constant of the universe which measures the strength of the electric field. The normal \hat{n} is the outward surface normal, the normal that points out of the surface.

Definition of a Closed Surface: A closed surface is a surface where you cannot go from inside the surface to outside the surface without passing through the surface. A balloon is a closed surface, a popped balloon is an open surface.

Gauss' Law is a fairly extraordinary expression, since it allows the computation of an exceptionally nasty integral expression simply by counting the charge enclosed. For example, consider the following:

Example 11.2 Gauss' Law for a Dipole

Problem: A dipole is formed of $\pm Q$ charges separated by a distance L spaced along the x -axis and centered at the origin.

- Compute $\int_S (\vec{E} \cdot \hat{n}) dA$ where S is a sphere of radius $2L$ centered at the origin and \hat{n} is the outward normal.
- Repeat the computation if the $+Q$ charge is removed.

Solution to Part (a)

By Gauss' Law, since $Q_{\text{enclosed}} = 0$,

$$\phi_e = 0 = \int_S (\vec{E} \cdot \hat{n}) dA.$$

Solution to Part (b)

By Gauss' Law, since $Q_{\text{enclosed}} = -Q$,

$$\phi_e = \frac{-Q}{\epsilon_0}.$$

Now, consider how you would do this integral without Gauss' Law. The second question is, why would you want to do this integral at all, and I can't think of a single reason. For actual uses of Gauss' Law, we need a little help from symmetry.

11.3 Specializing Gauss' Law to the Symmetry

11.3.1 Specializing Gauss' Law for Spherical Symmetry

To actually compute an electric field with Gauss' Law, we have to find some way to do the electric flux integral. A surface integral is a very difficult thing to compute, so we avoid it. We only compute electric fields with Gauss' Law in situations where the electric field is constant and normal (perpendicular) to the surface. We will call surfaces with these properties Gaussian surfaces. This allows the electric field to be brought outside the integral and the remaining integral is simply the area of the Gaussian surface. The trick is different for each of our high symmetry systems: planar, cylindrical, and spherical.

For a spherically symmetric charge distribution, use a spherical Gaussian surface. By symmetry, the electric field must have the same magnitude at all points on the Gaussian surface and be normal to the surface, pointing radially outward, therefore $\vec{E}(r) = E(r)\hat{r}$, where $E(r)$ is a constant over the surface.

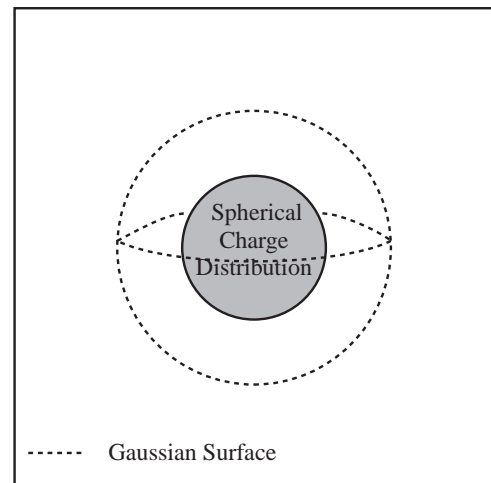

The electric flux through the Gaussian surface is by definition of electric flux:

$$\phi_e = \int_S (\vec{E} \cdot \hat{r}) dA.$$

where I have used $\hat{n} = \hat{r}$ for a spherical surface. Substitute $\vec{E} = E(r)\hat{r}$ and use $\hat{r} \cdot \hat{r} = 1$ to give

$$\phi_e = \int_S (\vec{E} \cdot \hat{r}) dA = \int_S (E(r)\hat{r} \cdot \hat{r}) dA = \int_S E(r) dA.$$

The electric field has the same magnitude at all points on the surface S , by symmetry, and can be brought out of the integral

$$\phi_e = E(r) \int_S dA.$$

The integral is just the area of the Gaussian surface, $4\pi r^2$,

$$\phi_e = 4\pi r^2 E(r)$$

By Gauss' Law, the electric flux is proportional to the charge enclosed,

$$\phi_e = \frac{Q_{\text{enclosed}}}{\epsilon_0}$$

Substituting the flux through the general surface, we get

$$4\pi r^2 E(r) = \frac{Q_{\text{enclosed}}}{\epsilon_0}$$

Gauss' Law for Spherical Systems: Gauss' law applied to a spherical surface with radius r for a spherically symmetric system of charge reduces to

$$4\pi r^2 E(r) = \frac{Q_{\text{enclosed}}}{\epsilon_0}$$

11.3.2 Specializing Gauss' Law to Cylindrical Systems

For systems with cylindrical symmetry, use a Gaussian surface which is a cylinder of radius r and length L , co-axial with the charge. The electric field points straight outward from the axis of the system and can be written $\vec{E} = E(r)\hat{r}$. If the axis of the system is the z axis then $\vec{r} = (x, y, 0)$

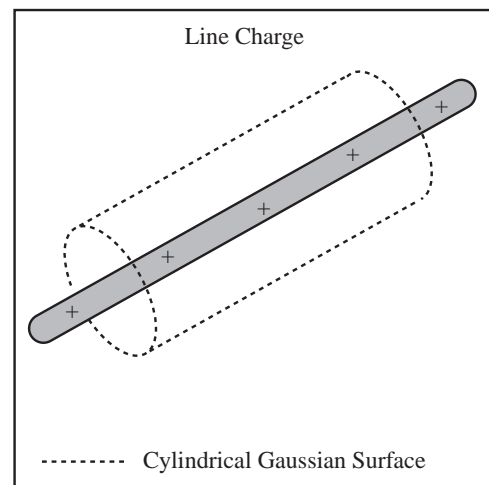

The electric flux is by definition

$$\phi_e = \int_S (\vec{E} \cdot \hat{n}) dA$$

The field at the flat ends of the Gaussian surface is perpendicular to the normal of the surface, so there is no flux out of the ends. Therefore, the integral has a non-zero value only on the curved sides. The outward normal of the Gaussian surface is $\hat{n} = \hat{r}$. By a reasoning similar to the spherical case,

$$\phi_e = \int_S (\vec{E} \cdot \hat{n}) dA = \int_S (E(r)\hat{r} \cdot \hat{r}) dA = E(r) \int_S dA$$

The surface area of a cylinder of length L and radius r excluding the ends is $2\pi rL$. Apply Gauss' Law,

$$\phi_e = 2\pi rL E(r) = \frac{Q_{\text{enclosed}}}{\epsilon_0}$$

Gauss' Law from Cylindrical Systems: Gauss' law applied to a cylindrical surface of radius r with length L for a system of charge with cylindrical symmetry reduces to

$$\phi_e = 2\pi rL E(r) = \frac{Q_{\text{enclosed}}}{\epsilon_0}$$

11.3.3 Specializing Gauss' Law for Planar Symmetry

For a system with planar symmetry, apply Gauss' Law to a Gaussian surface which is a cylinder with end of area A whose ends are parallel to the plane.

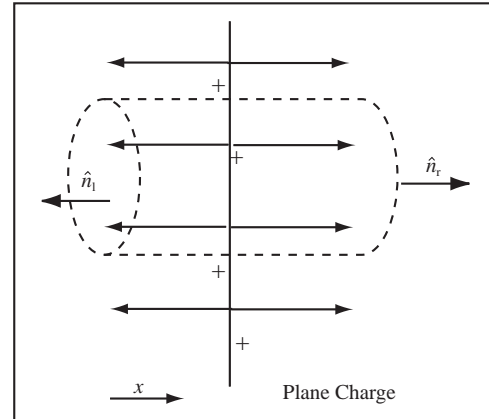

The electric flux for this Gaussian surface is

$$\phi_e = \int_S (\vec{E} \cdot \hat{n}) dA$$

Break the surface integral into an integral over the left end, the right end, and the sides.

$$\begin{aligned} \phi_e &= \int_{left} (\vec{E}_l \cdot \hat{n}_l) dA + \int_{right} (\vec{E}_r \cdot \hat{n}_r) dA \\ &\quad + \int_{sides} (\vec{E} \cdot \hat{n}_{sides}) dA \end{aligned}$$

where \vec{E}_l is the electric field at the left end of the cylinder and \vec{E}_r is the electric field at the right end. The integral over the sides is zero because the electric field is perpendicular to the surface normal at all times, so the dot product is zero. $\int_{sides} (\vec{E} \cdot \hat{n}_{sides}) dA = 0$. Let $\vec{E}_l = E_l \hat{x}$ and $\vec{E}_r = E_r \hat{x}$. From the diagram, we can see $\hat{n}_l = -\hat{x}$, $\hat{n}_r = \hat{x}$. Substitute this into Gauss' Law,

$$\phi_e = \int_{left} E_l (\hat{x} \cdot (-\hat{x})) dA + \int_{right} E_r (\hat{x} \cdot \hat{x}) dA = \int_{left} -E_l dA + \int_{right} E_r dA$$

since $\hat{x} \cdot \hat{x} = 1$. By symmetry, the field is constant on the ends of the Gaussian cylinder and can be removed from the integral,

$$\phi_e = -E_l \int_{left} dA + E_r \int_{right} dA$$

The integrals are simply the areas of the ends of the cylinder.

$$\phi_e = -E_l A + E_r A$$

Apply Gauss' law,

$$\phi_e = -E_l A + E_r A = \frac{Q_{enclosed}}{\epsilon_0} = (E_r - E_l) A$$

For system above, the total charge enclosed in the Gaussian surface would be $Q_{enclosed} = \sigma A$, where σ is the surface charge density of the plane.

Gauss' Law for Planar Systems: For a system with planar symmetry, Gauss' Law applied to a cylinder with end of area A whose ends are parallel to the plane reduces to

$$\phi_e = -E_l A + E_r A = \frac{Q_{enclosed}}{\epsilon_0}$$

where E_l is the electric field at the left end of the cylinder and E_r is the electric field at the right end of the cylinder.

11.3.4 Another Way to Look At It

Well, that was a mess. If you look over what was done, each case involved finding a surface, S , where the electric field was either parallel to the surface normal and constant or perpendicular to the surface normal at all points. This allowed the calculation of the flux as $\phi_e = (\vec{E} \cdot \hat{n})A = EA$ for the parallel case and $\phi_e = (\vec{E} \cdot \hat{n})A = 0$ for the perpendicular case. Gauss' law applies to any surface; we will call surfaces with these special properties *Gaussian surfaces*.

Definition of Gaussian Surface: A *Gaussian surface* is surface where the electric field is constant and parallel to the surface normal or perpendicular to the surface at all points on the surface.

If we let the area of the Gaussian surface with non-zero flux be A_g , then Gauss' law assumes the much simpler form $\phi_e = EA_g = Q_{enc}/\epsilon_0$. For example, in spherical systems we use a spherical Gaussian surface of radius r , the area of the surface is $A_g = 4\pi r^2$ and the specialized form of Gauss' law is $\phi_e = EA_g = 4\pi r^2 E = Q_{enc}/\epsilon_0$. The same expression we worked so hard to extract with vector methods. For cylindrical systems where the surface has radius r and length L , the area is $A_g = 2\pi rL$, and Gauss' law becomes $\phi_e = EA_g = 2\pi rLE = Q_{enc}/\epsilon_0$. For planar systems, we have to take care of the fact the flux is inward at the left side of the cylinder and has a negative sign, $-E_l A$, and outward at the right end of the cylinder, $E_r A$, giving Gauss' law as $-E_l A + E_r A = Q_{enc}/\epsilon_0$.

Gauss' Law Applied to a Gaussian Surface: If the area of the Gaussian surface with non-zero flux is A_g , then Gauss' law becomes

$$\phi_e = EA_g = \frac{Q_{enc}}{\epsilon_0}.$$

11.4 Application of Gauss' Law

This section presents examples of the calculation of the electric field in spherical, planar, and cylindrical symmetry. Unlike previous electric field calculations where the electric field was computed at a single point, here the electric field is computed at all points in space and reported as a function.

11.4.1 Applying Gauss' Law to Spherically Symmetric Distributions of Charge

For a spherical system, the appropriate Gaussian surface is a sphere of radius r . The field is radial and has the form $\vec{E} = E(r)\hat{r}$ Gauss' law applied to this surface becomes

$$4\pi r^2 E(r) = \frac{Q_{enclosed}}{\epsilon_0}$$

Solving for E and writing the field as a vector yields

$$\vec{E}(\vec{r}) = \frac{Q_{enclosed}}{4\pi\epsilon_0 r^2} \hat{r}$$

Notice, we had to add the direction of the field, \hat{r} , back in to write the full electric field. We had to know the direction of the field to choose our Gaussian surface to begin with.

We should start by applying Gauss' law to a point charge of charge q . If we don't recover Coulomb's law we're dead. For this case, $Q_{enc} = q$ for any radius surface and the electric field is

$$\vec{E}(\vec{r}) = \frac{Q_{enc}}{4\pi\epsilon_0 r^2} \hat{r} = \frac{q}{4\pi\epsilon_0 r^2} \hat{r} = \frac{kq}{r^2} \hat{r}$$

where I have used $k = 1/4\pi\epsilon_0$. Therefore, Coulomb's law and Gauss' law are equivalent.

Example 11.3 Spherical Charge Distribution with Imbedded Volume Charge

Problem: A spherical system of charge is shown to the right. The system is composed of a central point charge with charge $+2Q$. The point charge is imbedded in the center of a spherical volume of charge with volume charge density ρ and radius a . Surrounding the volume charge is a thin spherical shell of charge with radius b . The shell has surface charge density σ . For each region clearly state the charge enclosed by the Gaussian surface.

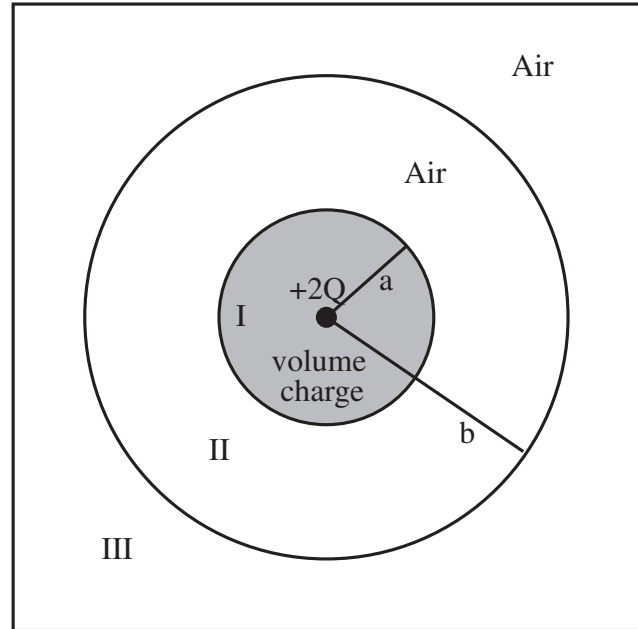

- Calculate the electric field in region *I*.
- Calculate the electric field in region *II*.
- Calculate the electric field in region *III*.
- If the total charge on the shell were $-2Q$ and the total charge on the volume charge is $+Q$ not including the charge of the point charge, draw the electric field everywhere using 4 lines per Q .
- To convert the general form of Gauss' law to one useful in this symmetry, the substitution $\hat{n} \Rightarrow \hat{r}$ is made in $\int_S (\vec{E} \cdot \hat{n}) dA$. Why can this be done?

Solution to Part (a)

Gauss' law states that the electric flux out of a closed surface is related to the charge enclosed in that surface by

$$\phi_e = \frac{Q_{enc}}{\epsilon_0}$$

The Gaussian surface is drawn below. For spherical symmetry, since $\vec{E} = E(r)\hat{r}$, this can be converted to

$$\phi_e = 4\pi r^2 E(r) = \frac{Q_{enc}}{\epsilon_0}$$

where r is the radius of the Gaussian surface. Solving for the field gives

$$\vec{E} = \frac{Q_{enc}}{4\pi r^2 \epsilon_0} \hat{r}$$

For a Gaussian surface with radius $r < a$ so that the outer edge of the surface lies in region *I*, the surface encloses the point charge and part of the volume charge: The charge enclosed in the surface is therefore

$$Q_{enc} = +2Q + \frac{4}{3}\pi r^3 \rho$$

therefore the electric field in region *I* is

$$\vec{E}_I = \frac{Q_{total}}{4\pi \epsilon_0 r^2} \hat{r} = \frac{2Q + \frac{4}{3}\pi r^3 \rho}{4\pi r^2 \epsilon_0} \hat{r}$$

Solution to Part (b)

An example of a Gaussian surface in region *II* is drawn below. For a Gaussian surface with radius $a < r < b$ in region *II* the charge enclosed is the point charge and all of the volume charge therefore:

$$Q_{enc} = +2Q + \frac{4}{3}\pi a^3 \rho$$

therefore the electric field in region *II* is

$$\vec{E}_{II} = \frac{Q_{total}}{4\pi\epsilon_0 r^2} \hat{r} = \frac{2Q + \frac{4}{3}\pi a^3 \rho}{4\pi r^2 \epsilon_0} \hat{r}$$

Solution to Part (c)

A spherical Gaussian surface with radius $b < r$ always encloses all the volume charge, the point charge, and the shell of charge, therefore for region *III*:

$$Q_{enc} = +2Q + \frac{4}{3}\pi a^3 \rho + 4\pi b^2 \sigma$$

therefore the electric field in region *III* is

$$\vec{E}_{III} = \frac{Q_{total}}{4\pi\epsilon_0 r^2} \hat{r} = \frac{2Q + \frac{4}{3}\pi a^3 \rho + 4\pi b^2 \sigma}{4\pi r^2 \epsilon_0} \hat{r}$$

Solution to Part (d)

Select 4 lines per Q . The total charge enclosed by a Gaussian surface in region *II* is $Q_{enc} = +3Q = 12$ lines outward. The total charge enclosed in region *III* is $Q_{enc} = +Q = 4$ lines outward. In region *I* the charge enclosed changes from $+3Q$ to $+2Q$ as the radius changes from a to 0 the number of lines change from 12 to 8

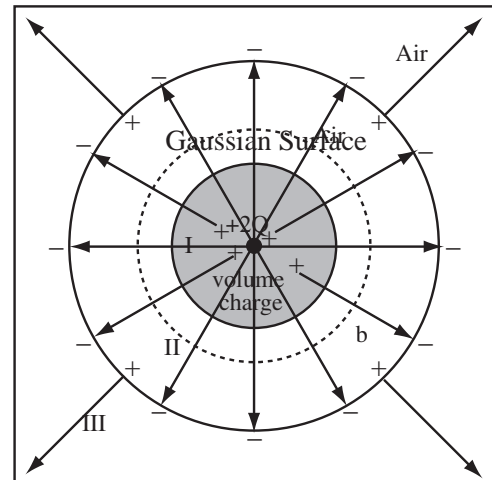

Solution to Part (e)

The Gaussian surface is a sphere so its outward surface normal is the vector \hat{r} .

11.4.2 Applying Gauss' Law to Planar Symmetry

I find planar symmetry a little more tricky than spherical symmetry, first because one has to introduce an arbitrary area and because there is the additional step of realizing the leftmost field is equal and opposite to the rightmost field. The appropriate Gaussian surface for planar symmetry is a cylinder with ends of area A . Since A is arbitrary, it must cancel from the calculation.

Use a Cylindrical Gaussian Surface: Use a cylinder with top and bottom parallel to the plane and side perpendicular to the plane.

Introduce an Arbitrary Area: Let the area of the top and the bottom of the cylinder be A . This should cancel out of the final calculation.

Gauss' law applied to the cylindrical surface becomes $E_{right}A - E_{left}A = Q_{enc}/\epsilon_0$. If you try to apply this blindly, you will find you are one equation short. You need the following interesting application of symmetry to actually do a planar problem.

Outer Fields are Equal and Opposite in a Planar System: The electric field for a planar system does not fall off with distance, therefore the magnitude of the field to the far right is always equal and in opposite direction to the field to the far left.

$$E_{leftmost} = -E_{rightmost}$$

Example 11.4 Two Infinite Parallel Planes of Charge

Problem: Two charged infinite parallel planes are spaced along the x -axis, the left plane with charge -3σ and the right plane with charge σ . What is the electric field in all regions of this system?

Solution

(a) Draw a good diagram: Use Gauss' Law Version 0 to draw the electric field of the system. Select 4 lines per σA . A Gaussian surface that encloses the entire system encloses $Q = -3\sigma A + \sigma A = -2\sigma A = 8$ lines entering from infinity. By symmetry, four enter from the right and four from the left. Now apply Gauss' law to left plane only, a Gaussian surface that encloses only the left plane encloses a charge of $-3\sigma A = 12$ lines entering the Gaussian surface. Four lines already enter from the left, so eight lines must enter from the right. Draw + charges where lines begin, - charges where lines end.

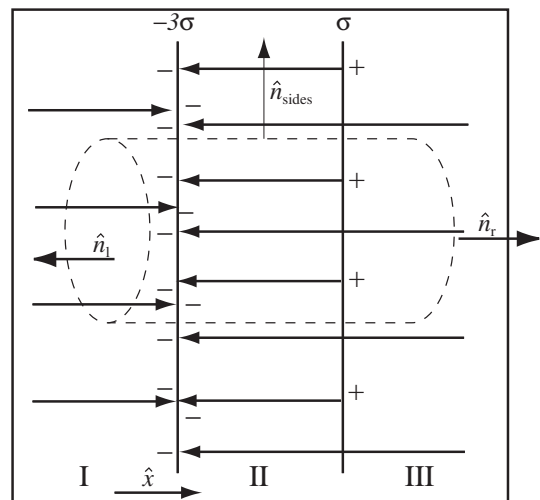

(b) Select and Draw the Gaussian Surface: For planes, the appropriate Gaussian surface is a cylinder whose left and right faces are parallel to the planes. Let the cylinder have end area A .

(c) Select the Appropriate Form of Gauss' Law for Planar Symmetry: For a planar system, the fields have the form $\vec{E}_I = E_I \hat{x}$, $\vec{E}_{II} = E_{II} \hat{x}$, and $\vec{E}_{III} = E_{III} \hat{x}$. The appropriate form of Gauss' law is

$$-E_l A + E_r A = \frac{Q_{enclosed}}{\epsilon_0}$$

or

$$E_r - E_l = \frac{Q_{enclosed}}{A\epsilon_0}$$

where E_r is the field at the right end of the Gaussian surface and E_l is the field at the left end of the Gaussian surface.

(d) Compute the Outer Fields: The electric field for infinite planes does not change with distance, therefore the electric field at the very left of the system is equal and opposite to the electric field at the very right of the system.

$$E_I = -E_{III}$$

Apply our general form for Gauss' Law of parallel planes to a Gaussian surface with one end in Region I and one end in Region III as drawn above,

$$E_r - E_l = E_{III} - E_I = \frac{Q_{enclosed}}{A\epsilon_0}$$

The total charge inside our Gaussian surface is $(-3\sigma + \sigma)A = -2\sigma A = Q_{\text{enclosed}}$

$$E_{III} - E_I = \frac{-2\sigma A}{\epsilon_0 A} = \frac{-2\sigma}{\epsilon_0}$$

Using $E_I = -E_{III}$ gives,

$$2E_{III} = \frac{-2\sigma}{\epsilon_0}$$

$$\vec{E}_{III} = \frac{-\sigma}{\epsilon_0} \hat{x}$$

$$\vec{E}_I = -\vec{E}_{III} = \frac{\sigma}{\epsilon_0} \hat{x}$$

(e) Compute the Field in Region II: Work from left to right. Now, use a Gaussian surface that only encloses the left plane. Apply the general formula for Gauss' Law with planar symmetry,

$$E_r - E_l = E_{II} - E_I = \frac{Q_{\text{enclosed}}}{A\epsilon_0}$$

The total charge inside the Gaussian surface is $Q_{\text{enclosed}} = -3\sigma A$.

$$E_{II} - E_I = \frac{-3\sigma A}{A\epsilon_0} = \frac{-3\sigma}{\epsilon_0}$$

$$E_{II} = \frac{-3\sigma}{\epsilon_0} + E_I = \frac{-3\sigma}{\epsilon_0} + \frac{\sigma}{\epsilon_0} = \frac{-2\sigma}{\epsilon_0}$$

$$\vec{E}_{II} = \frac{-2\sigma}{\epsilon_0} \hat{x}$$

Check the fields have the same magnitude and direction as the field map.

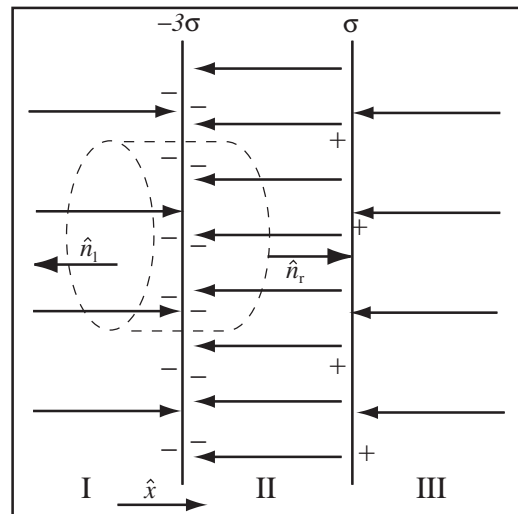

11.4.3 Applying Gauss' Law to Cylindrical Systems

The appropriate Gaussian surface for a system with cylindrical symmetry is a cylindrical surface of length L and radius r co-axial with the system. The area of such a surface is $2\pi rL$ and Gauss' law applied to the surface is $\phi_e = 2\pi rLE(r) = Q_{\text{enc}}/\epsilon_0$.

Example 11.5 Electric Field of Cylindrical Tube of Charge

Problem: An infinitely long tube of charge has uniform volume charge density ρ and radius a . Calculate the field everywhere.

Solution

(a) **Draw the System:** Field lines begin at various places within the volume charge and point radially outward.

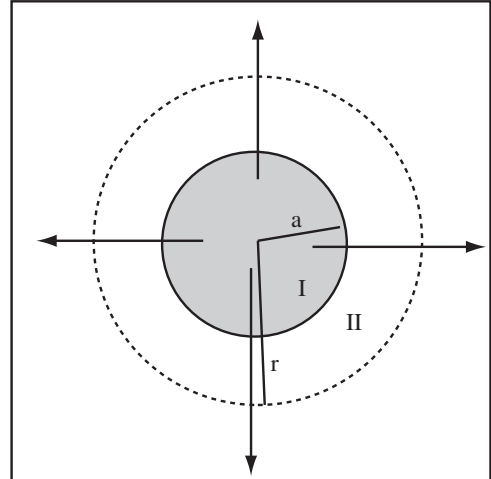

(b) **Select Appropriate form of Gauss' Law and a Gaussian Surface:** The appropriate Gaussian surface for a cylindrical system is a cylinder of length L and radius r . The electric field is radial and has the form $\vec{E} = E(r)\hat{r}$ where now $\vec{r} = (x, y, 0)$ if the axis of the system is the z axis. For this surface, Gauss' law can be reduced to $2\pi rLE(r) = Q_{enc}/\epsilon_0$ or writing the field as a vector

$$\vec{E} = \frac{Q_{enc}}{2\pi\epsilon_0 rL} \hat{r}$$

(c) **Calculate the Field in Region I:** A Gaussian surface in region I encloses part of the volume charge. The charge enclosed by a Gaussian surface with radius $r < a$ is the volume of the surface, the area of the end πr^2 multiplied by L , time the charge density ρ ,

$$Q_{enc} = \pi r^2 L \rho$$

and therefore the electric field in region I is

$$\vec{E}_I = \frac{Q_{enc}}{2\pi\epsilon_0 rL} \hat{r} = \frac{\pi r^2 L \rho}{2\pi\epsilon_0 rL} \hat{r} = \frac{r\rho}{2\epsilon_0} \hat{r}$$

(d) **Calculate the Field in Region II :** A Gaussian surface in region II encloses all of the volume charge. The charge enclosed by a Gaussian surface with radius $r > a$ is

$$Q_{enc} = \pi a^2 L \rho$$

and therefore the electric field in region II is

$$\vec{E}_{II} = \frac{Q_{enc}}{2\pi\epsilon_0 rL} \hat{r} = \frac{\pi a^2 L \rho}{2\pi\epsilon_0 rL} \hat{r} = \frac{a^2 \rho}{2\epsilon_0 r} \hat{r}$$

Note in both regions the arbitrary length L cancelled.

Chapter 12

Final Topics Test 1

This chapter covers the final few topics for systems where the location of all charge is known. This is in contrast to next chapter where we have to figure out the location of the charge.

12.1 Long Range Fields

We are beginning to be able to build up some very complicated charge distributions. While we were drawing field maps we used the fact that far from a system of net charge the field was radial and far from a system with zero net charge but non-zero dipole moment, the field had a characteristic dipole shape. I would like to return to this result quantitatively.

Field Far from a System of Net Charge: The electric field at a point far from a system with net non-zero charge (compared to the extent of the system), is the field of a point charge at the center of the system with charge, Q_{total} , the total charge of the system.

Long Range Field of a Dipole System: If a system has zero net charge, but non-zero dipole moment \vec{p} , the electric field far from the charge will be the electric field of a simple dipole with dipole moment \vec{p} .

Example 12.1 Electric Field Far from a Complicated System of Charge

Problem: Consider the system to the right. The two spherical volume charges have uniform volume charge density ρ and radii a . The disk has uniform surface charge density σ and radius b . All charge densities are positive. Calculate the electric field at all points $r \gg a$ and $r \gg b$.

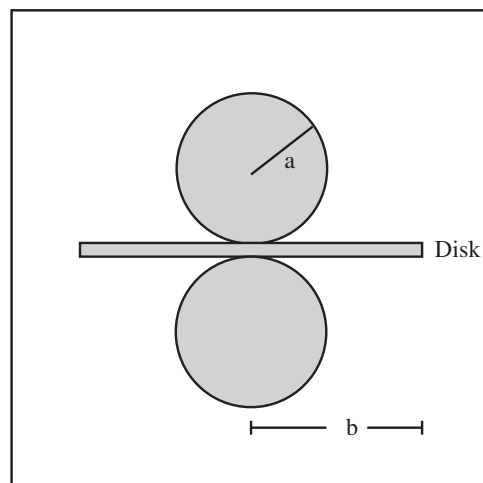

Solution

Since all charge densities are positive, the system has a net charge and therefore the field far from the system is that of a point charge with the total charge of the system, Q_{total} . The total charge is the sum of the total charge of both shells and the volume charge

$$Q_{total} = \frac{4}{3}\pi\rho a^3 + \pi b^2\sigma + \frac{4}{3}\pi\rho a^3$$

Therefore, the electric field far from the system is

$$\vec{E} = \frac{kQ_{total}}{r^2}\hat{r} = k\frac{\frac{4}{3}\pi\rho a^3 + \pi b^2\sigma + \frac{4}{3}\pi\rho a^3}{r^2}\hat{r}$$

12.2 Gauss' Law Inside and Outside All Charge

One of the most powerful applications of Gauss' Law is not the calculation of the detailed electric field of a complicated system of charge, but the calculation of the electric field either completely outside or completely inside a system of charge. The following rules allow immediate calculation of the electric field for the innermost and outermost regions of highly symmetric charge distributions.

Electric Field Outside All Charge - Spherical Symmetry: The exact field of a spherically symmetric charge distribution at a radius r outside of all charge is the field of a point charge with charge equal to the total charge, Q_T , of the distribution

$$\vec{E}_{outside} = \frac{Q_T}{4\pi\epsilon_0 r^2}\hat{r} = \frac{kQ_T}{r^2}\hat{r}$$

Electric Field inside all Charge - Spherical Symmetry: For a spherically symmetric system of charge, if we are inside all charge then the electric field is zero.

Electric Field Inside All Charge - Cylindrical Geometry: Inside all charge for a cylindrically symmetric charge distribution, the electric field is zero.

Electric Field Outside All Charge - Cylindrical Symmetry: The electric field outside all charge for a cylindrically symmetric distribution of charge is

$$\vec{E}(r) = \frac{\lambda}{2\pi\epsilon_0 r}\hat{r}$$

where $\lambda = Q_T/L$ with Q_T the total charge of a length L of the system.

Planar systems are somewhat different because the concept of inside and outside does not make much sense. There is no center for a planar system. For planar systems, we can consider the electric field to the far right and far left of the system.

Electric Field Outside All Charge - Planar Symmetry: For a system with planar symmetry, far from all charge, the electric field is the same as a single plane with charge density being the total charge density of the system

$$\vec{E} = \frac{\sigma_T}{2\epsilon_0} \quad \text{outward.}$$

The total charge density can be computed by taking a cylindrical Gaussian surface with end area A and finding the total charge in it, Q_T , $\sigma_T = Q_T/A$.

Chapter 13

Conductors and Dielectrics

13.1 Response of Materials

13.1.1 The Electric Response of Conductors

We have been qualitatively drawing the response of conductors and dielectrics to external electric fields since the second day of the course, where you learned how the golf tube attracted the soda can and the plastic bottle. If you will recall, the attraction was explained by reasoning that the electric force of the golf tube induced a surface charge on each object, then the forces on these charge densities from the external object caused the motion. Our analysis of conductors and dielectrics will follow this pattern: (1) Find the field of the external object, (2) Find the induced surface charges, and (3) Add the field of the induced charges to the field of the static charges to get the total field. For static electric fields, conductors and dielectrics are just another source of charge. Once this charge is accounted for, the material can be forgotten. For electromagnetism, it is always useful to remember:

UPII Mantra: There is only charge and field.

For twelve chapters, we have been considering systems of charge that are distributed through space and mysteriously stay put even though since like charges repel they should blow apart. In lab, not surprisingly, we've had to place charge on conductors and dielectrics to work with it. We know when conductors or dielectrics are placed in an electric field, that surface charge appears on the surface, since we've been drawing pictures like the one below since the first week of class.

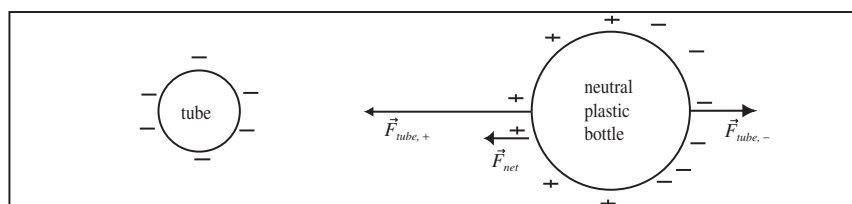

Some of our observations about the qualitative behavior of conductors will allow us to deduce the key mathematical relations governing conductors in an electric field. Recall the following:

- **Charge can move in a conductor.**
- **The net electric force inside a conductor is zero.** We argued that charge separation would occur until the total force on the electrons (and protons) inside a conductor is zero. The total force is the sum of the external force and the electric force of the separated charge.
- **Charge will move in response to an electric force.** If there is a net electric force on charges in a conductor the charges will accelerate and move.

From these observations, we can deduce these laws for the electric field inside a conductor in electrostatic equilibrium:

Electric Field Inside the Conductor is Zero: The mobile charge in a conductor rearranges itself to produce zero electric field, $\vec{E} = 0$, in the interior of the conductor. If there was a net field, charge would move.

It is somewhat unbelievable that a conductor can accomplish this at all points no matter what. I have always found the following the most convincing argument for the need for zero electric field in a conductor. Suppose the field was not zero. Since there is mobile charge in a conductor, there would be a flow of charge, an electric current. Electric currents in conductors cause heating and therefore a loss of energy. This cannot happen indefinitely. Eventually, the conductor must reach an equilibrium where the current is zero and therefore the field is zero.

The same reasoning can be used to show the electric field must be perpendicular to the surface of the conductor. Suppose the electric field, \vec{E}_0 , was not normal to the surface at some point as shown to the right. The field could be decomposed into a field perpendicular to the surface \vec{E}_{\perp} and a field parallel to the surface \vec{E}_{par} . The component of the field parallel to the surface will cause currents to flow along the surface. The surface charge will rearrange until these currents stop.

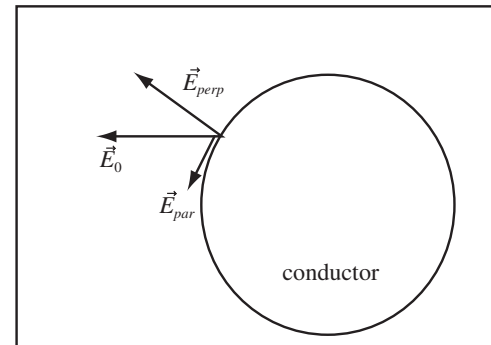

Electric Field is Normal to a Conductor Surface: At the surface of the conductor \vec{E} is perpendicular to the surface. If \vec{E} were not perpendicular (normal) to the surface, there would be a component of the electric field along the surface and the surface charge would move along the surface.

Definition of Induced Charge: An applied electric field is reduced to zero in a conductor by the field of a surface charge that forms on the conductor. This surface charge is called the induced charge.

The requirement that the field is zero in a conductor places restrictions on the location of net charge on the conductor.

All net charge on a conductor is at its surface: If net charge existed inside a conductor, there would be a region around the net charge (by Gauss' Law) where there was a non-zero electric field. This would cause charge to flow. Charge would continue to flow until the field was zero and the region of net charge was removed.

All Charge is at the Outer Surface of a Conductor:

If a conductor has a cavity that does not contain a fixed charge, then there is no surface charge density on conductor at the cavity. Therefore all the surface charge density is on the outer surface of a conductor. This is not true if there is a net charge in the cavity. One can show this by placing a Gaussian surface in the conductor around the cavity. Since the electric field on the surface is zero, the surface contains zero net charge.

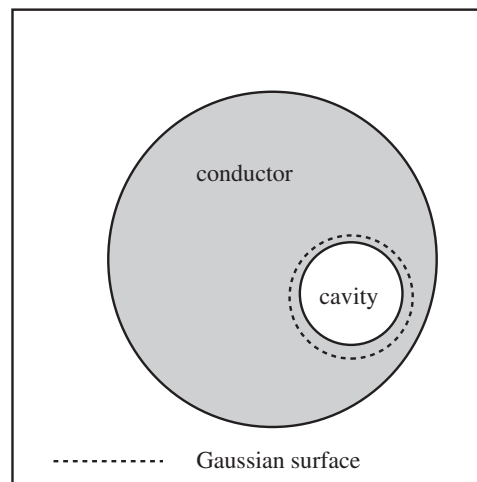

Example 13.1 Why is Electric Field Zero in a Conductor?

Problem: Explain why the electric field in a conductor is zero.

Solution

The electric field is just the electric force that a positive charge would feel. In Course Guide 2 Electric Force I, we asked the question, “Why doesn’t all the charge separate out of a conductor?” We reached the conclusion that each charge that separates partially cancels the electric force that the next charge would feel. The same reasoning applies to the electric field in a conductor. Initially, the electric field causes electrons to move to one surface, leaving a positive region on the other surface. The electric field for these separated charges partially cancels the external electric field. More charge separates until the electric field is zero inside the conductor. If the field were not zero, more charge would be pushed to the surface.

Alternately, if the electric field is not zero, charge must flow until the electric field becomes zero.

13.1.2 Basic Properties of Dielectrics

The conductor accomplished the reduction of electric field in its interior by generating an induced surface charge. The dielectric reduces the electric field in its interior because a surface charge results from the stretching of the atoms. This surface charge is called a *bound charge*. The surface charge sets up an electric field that partially, but not completely, cancels the applied field. The factor by which the electric field is reduced is called the dielectric constant and denoted by the symbol κ .

Response of Dielectric to Applied Electric Field: In each small volume of its interior, a dielectric reduces the field that would have existed if the volume did not contain dielectric, \vec{E}_0 , by a factor of the dielectric constant, κ , to a field in the dielectric of \vec{E}_0/κ . The dielectric constant is a property of the material.

Dielectric Constant: The amount a dielectric can be polarized is characterized by the dielectric constant, κ . Dielectric constants are always greater than or equal to 1. The dielectric constant of air may be taken to be 1. The dielectric constant of empty space is by definition 1. The Greek symbol κ is pronounced “kappa”.

This is a very difficult behavior to deal with in practice because the field that would have existed in the dielectric depends not only the applied field, but also the field of the bound surface charges produced by polarization of the dielectric.

Bound Surface Charge: When a dielectric (also called an insulator) is placed in an electric field, the charge in the atoms or molecules which make up the material separates slightly, but there is no macroscopic charge movement. The slight separation of the atomic charges produces a bound charge density at the surface of the dielectric. The location of the bound charge can be found by the drawing the field map and finding where lines begin and end on the dielectric.

Dielectric Constants

	κ
space	1
air	1.00059
Plexiglas	3.40
Glass	5-10
PVC	3.18
Water	80

Electric Field Bends Closer to Normal at Dielectric Surface: At the surface of a dielectric in an applied field, the electric field bends closer to perpendicular to the surface than the field without the dielectric present.

13.1.3 Dielectric Breakdown

A dielectric produces a surface charge by deforming the atoms of the dielectric. Like anything else, an atom cannot be stretched indefinitely. At high enough fields, the atom comes apart losing one or more of its outer electrons. Both the electrons and the charged atom (ion), become mobile charge in the material. The dielectric breaks down. For air we get a spark. Every material breaks down at a different maximum electric field.

Dielectric Breakdown: Dielectrics stay insulating only for electric fields below a certain magnitude, otherwise you obtain a spark and a current flows. The magnitude of the electric field where the dielectric begins to spark is the dielectric breakdown voltage. For dry air, dielectric breakdown happens at $|\vec{E}| = 3 \times 10^6 \text{ N/C}$.

13.2 Field Maps of Point Charges

To add a conductor or dielectric to an electric field map or to an electric field problem, we first solve the problem for the static net charge, then fix up the field map by correcting for the conductor or dielectric.

Fixing the Conductors: First erase any field lines crossing a conductor because the field inside a conductor is zero, then bend the field lines that intersect the conductor so they are normal to the conductor surface.

Fixing the Dielectrics: First thin field lines crossing the dielectric by a factor of the dielectric constant κ , so if $\kappa = 2$ erase half the lines, and if $\kappa = 3$ erase $\frac{2}{3}$ of the lines, then bend the field lines which intersect the dielectric so they are closer to the normal of the dielectric surface.

Draw Induced and Bound Charge: Draw + charge where field lines begin and – charge where field lines end.

Example 13.2 Drawing the Electric Field Map with Dielectrics Present

Problem: Draw the electric field map of one point charge, $+Q$, and an uncharged dielectric sphere with dielectric constant $\kappa = 3$.

Solution

Strategy: Draw the fixed charge map, then thin the lines in the dielectric by κ and bend them toward the surface normal.

(a) Draw the field of the fixed charges: Draw the field of the fixed charge. Since the dielectric is uncharged, just draw the physical location of the dielectric.

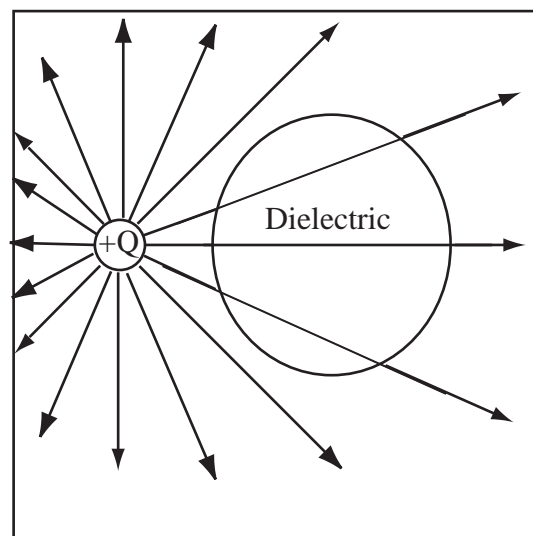

(b) Thin Field Lines in the Dielectric: The dielectric will thin the field lines which cross it in proportion to its dielectric constant. So if $\kappa = 3$, the field lines are a third as dense. Erase an appropriate number of field lines within the dielectric. There were 3 field lines inside the dielectric, and $3/\kappa = 1$, so erase 2 field lines.

(c) Bend Lines At the Dielectric and Label Bound Charge: Field lines bend toward the normal at the surface of a dielectric, but unlike a conductor they do not bend all the way to normal. The field lines which begin and end on the dielectric surface must begin and end on charge. The law that the field must be radial at infinity still applies. The net field lines exiting the surface must be correct for the charge; so if the dielectric is uncharged, the same number of lines that go in must come out. Place + charge where lines begin and - where lines end. The same number of lines come out as go in, which is correct for an un-charged object.

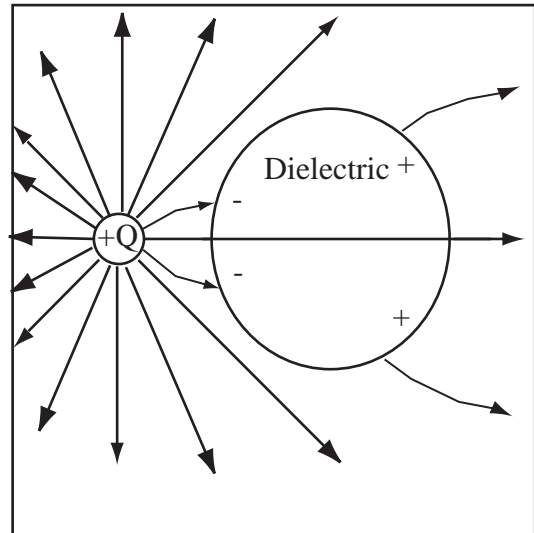

(d) Bend Lines to Fill Gaps: We have only touched field lines which cross the dielectric; but, this leaves gaps where we have a straight line next to a strongly bent line. Bend the straight lines some to fill in the gap. This may make more lines intersect the dielectric. The goal is once again to have a distribution of evenly spaced field lines far from the source. I bent the field lines next to those which intersect the dielectric. No further lines intersected the dielectric.

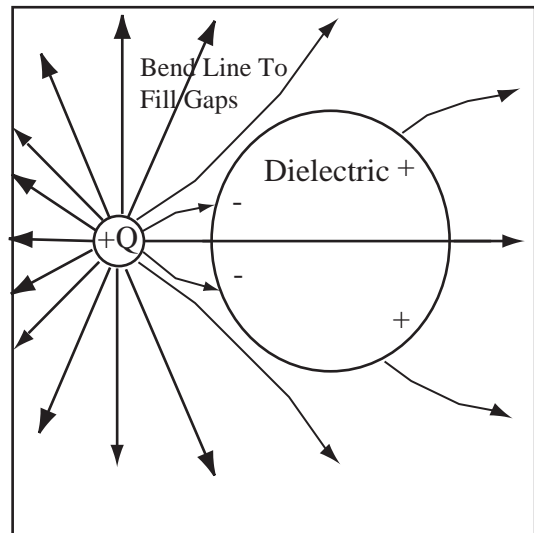

Example 13.3 Drawing the Electric Field Map with Conductors Present

Problem: Draw the electric field map of one point charge, $+Q$, and an uncharged conducting sphere.

Solution

(a) Draw the field of the fixed charges: Draw the field of the fixed charge. Sketch the location of the conductor and erase the lines inside, because $\vec{E} = 0$ in a conductor.

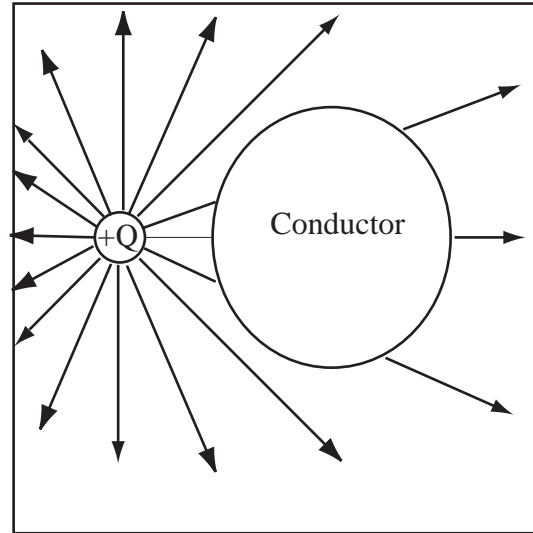

(b) Bend Lines Normal To Conductor and Label Charge: The picture above doesn't satisfy the condition that field lines must be normal at the surface of a conductor. To fix this, bend the lines so that they are perpendicular to the conductor surface. The law that the field must be radial at ∞ still applies. Label the induced charge. Field lines begin on + charge and end on - charge.

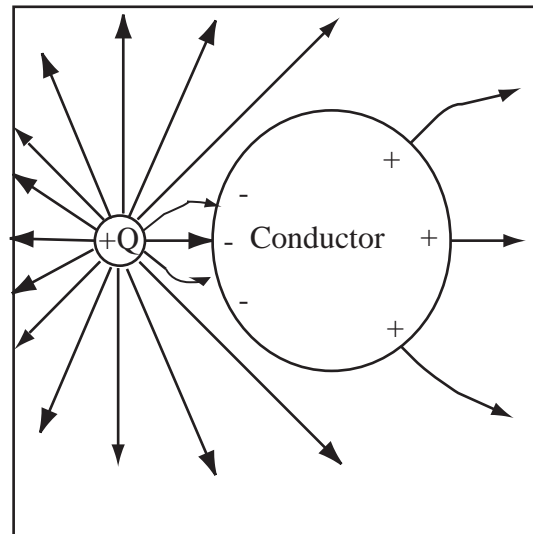

(c) Conserve the Induced Charge: The net number of lines leaving the conductor must be correct for its charge. So if the conductor is uncharged, the lines entering must equal the lines leaving. Counting field lines will show that no net lines are leaving, so the conductor is uncharged.

(d) Bend Lines to Fill Gaps: We have only touched field lines which cross the conductor; but this leaves gaps where we have a straight line next to a strongly bent line. Bend the straight lines some to fill in the gap. This may make more lines intersect the conductor. The goal is once again to have a distribution of evenly spaced field lines far from the source. To fill in gaps in the field, four lines were bent causing two more lines to intersect with the conductor.

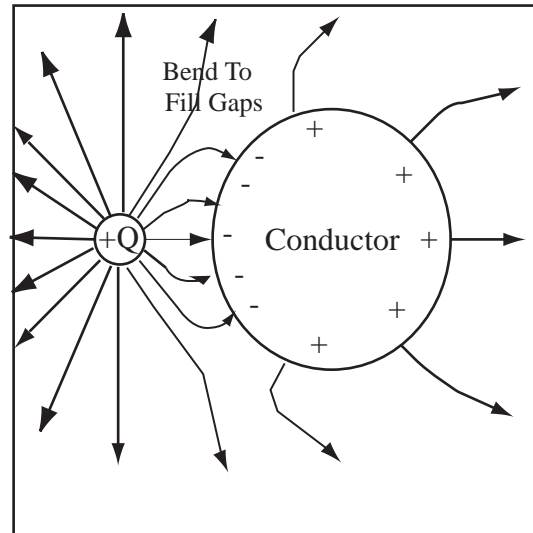

13.3 Charge Density at a Surface

Conductors and dielectrics affect the electric field because they produce surface charge densities. We need a method to calculate these surface charge densities, if we can figure out the field. This can be done by using a Gaussian surface with sides immediately on either side of the surface charge. If the area of the cylinder is small, the electric field does not change much over the faces of the cylinder, and may be approximated as constant. If the height of the cylinder is short enough, there is no flux out the sides. Such a cylinder will be called a *Gaussian pillbox*. Since the height of the cylinder is small, the ends of the cylinder have the same normals as the surface.

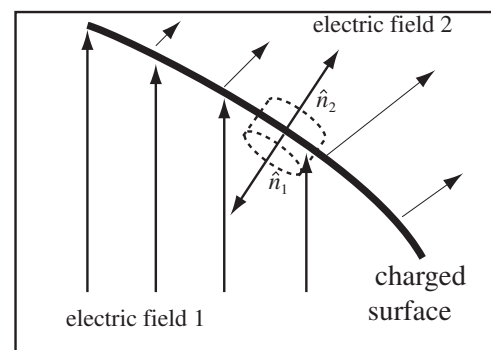

We can write Gauss' law for the cylinder as $\phi_1 + \phi_2 = \frac{Q_{enc}}{\epsilon_0}$, where ϕ_1 is the electric flux out of the surface with normal \hat{n}_1 and ϕ_2 is the flux out of surface with normal \hat{n}_2 . The charge enclosed in the pillbox is the surface charge density we are looking for, σ , multiplied by the area of the end A , $Q_{enc} = \sigma A$. Since the field is approximately constant over the surface, $\phi_1 = \vec{E}_1 \cdot \hat{n}_1 A$ and $\phi_2 = \vec{E}_2 \cdot \hat{n}_2 A$, where E_i is the field on either side of the surface.

$$\phi_1 + \phi_2 = \vec{E}_1 \cdot \hat{n}_1 A + \vec{E}_2 \cdot \hat{n}_2 A = \frac{\sigma A}{\epsilon_0}$$

or cancelling A and multiplying by ϵ_0

$$\epsilon_0(\vec{E}_1 \cdot \hat{n}_1 + \vec{E}_2 \cdot \hat{n}_2) = \sigma$$

Surface Charge Density in Gaussian Pillbox: The surface charge density in Gaussian pillbox with normals \hat{n}_1 and \hat{n}_2 is

$$\epsilon_0(\vec{E}_1 \cdot \hat{n}_1 + \vec{E}_2 \cdot \hat{n}_2) = \sigma$$

where \vec{E}_1 and \vec{E}_2 is the electric field on either side of the surface.

Example 13.4 Gauss' Law at a Flat Surface

Problem: In the region $x < 0$, the electric field is $\vec{E}_- = 100 \frac{\text{N}}{\text{C}} \hat{x} + 50 \frac{\text{N}}{\text{C}} \hat{y}$ and in the region $x > 0$ the electric field is $\vec{E}_+ = 180 \frac{\text{N}}{\text{C}} \hat{x} + 50 \frac{\text{N}}{\text{C}} \hat{y}$. Calculate the surface charge density in the y - z plane.

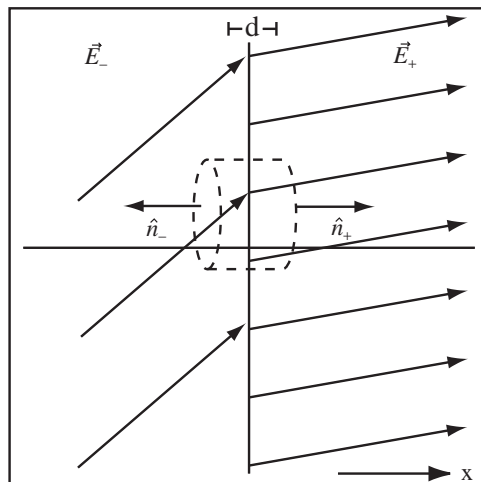

Solution

(a) **Draw the Gaussian Surface:** Use the Gaussian pillbox drawn above. Gauss' law applied to the pillbox is

$$\vec{E}_- \cdot \hat{n}_- A + \vec{E}_+ \cdot \hat{n}_+ A = \frac{\sigma A}{\epsilon_0}$$

$$\vec{E}_- \cdot \hat{n}_- + \vec{E}_+ \cdot \hat{n}_+ = \frac{\sigma}{\epsilon_0}$$

(b) **Work out the Dot Products:** By observation, $\hat{n}_- = -\hat{x}$ and $\hat{n}_+ = \hat{x}$,

$$\vec{E}_- \cdot \hat{n}_- = \vec{E}_- \cdot (-\hat{x}) = -100 \frac{\text{N}}{\text{C}}$$

$$\vec{E}_+ \cdot \hat{n}_+ = \vec{E}_+ \cdot (\hat{x}) = 180 \frac{\text{N}}{\text{C}}$$

Apply Gauss' law,

$$\sigma = \epsilon_0 (\vec{E}_- \cdot \hat{n}_- + \vec{E}_+ \cdot \hat{n}_+) = (8.85 \times 10^{-12} \frac{\text{C}^2}{\text{Nm}^2}) (-100 \frac{\text{N}}{\text{C}} + 180 \frac{\text{N}}{\text{C}}) = 7.1 \times 10^{-10} \frac{\text{C}}{\text{m}^2}$$

The expression above can be used at any surface. It can be simplified quite a bit if the surface and the field have planar symmetry.

Surface Charge Density at Planar Surface: If the field is perpendicular to the surface as shown to the right, then the surface charge density at the surface is given by

$$\epsilon_0 (E_2 - E_1) = \sigma$$

where E is positive if it points to the right.

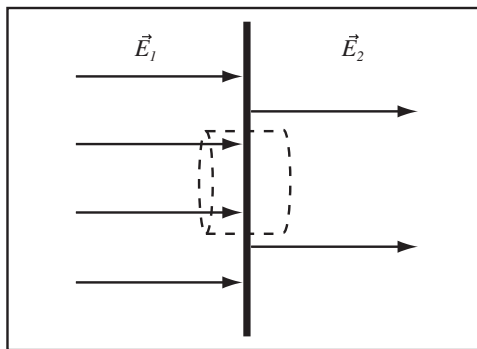

13.4 Planar Conductors and Dielectrics

13.4.1 Response of a Plane Conductor

The methods of the previous section can be used to calculate the induced surface charge density on a planar conductor in a uniform external electric field. The conductor reduces the electric field in its interior while not disturbing the electric field outside the conductor, as drawn to the right. Using the Gaussian pillbox drawn, the surface charge density of the left surface is $-\sigma_c = \epsilon_0(E_{right} - E_{left}) = \epsilon_0(0 - E_0)$, so $\sigma_c = \epsilon_0 E_0$. From the drawing, the charge on the right surface is positive and the charge on the left surface is negative.

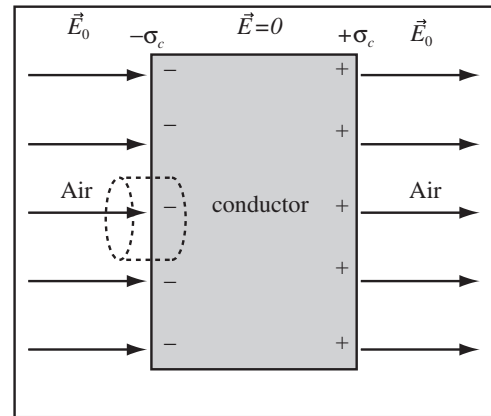

Surface Charge Density at Conductor Surface: The surface charge density at a conductor's surface is

$$\sigma = \pm \epsilon_0 E$$

where E is the field immediately outside the surface. E is positive if field lines leave the surface.

13.4.2 Response of a Plane Dielectric

A planar dielectric is sufficiently symmetric that the electric field in its interior can be quantitatively predicted.

Decrease in Electric Field : The electric field is reduced inside the dielectric by the field of the bound charge. The dielectric constant, κ , tells how much the electric field is reduced inside the dielectric. So in symmetric geometries if the electric field would have been \vec{E}_0 with no dielectric, then the electric field becomes $\vec{E}_\kappa = \vec{E}_0/\kappa$ inside the dielectric. The figure below is drawn assuming $\kappa = 2$ so there are half the field lines in the dielectric.

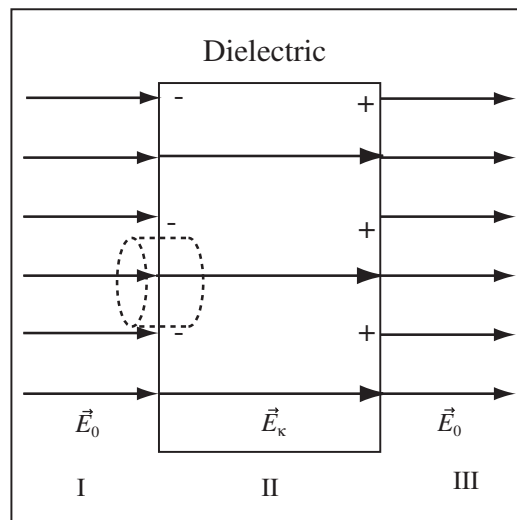

The magnitude of the bound surface charge density can be found by applying Gauss' law to a Gaussian pillbox shown surrounding the left surface of the dielectric. Gauss' law yields

$$-\sigma_b = \varepsilon_0(E_{II} - E_I) = \varepsilon_0\left(\frac{E_0}{\kappa} - E_0\right) = \varepsilon_0 E_0\left(\frac{1}{\kappa} - 1\right)$$

$$\sigma_b = \varepsilon_0 E_0\left(1 - \frac{1}{\kappa}\right)$$

Magnitude of Bound Charge at Dielectric Surface: The bound charge density at the surface of a planar dielectric with dielectric constant κ is

$$\sigma_b = \pm \varepsilon_0 E_0\left(1 - \frac{1}{\kappa}\right)$$

Polarization Electric Field : The electric field in the dielectric is decreased because the bound charge creates an electric field \vec{E}_b . The electric field in the dielectric, \vec{E}_κ , is the vector sum of the field in free space, \vec{E}_0 , and \vec{E}_b ,

$$\vec{E}_\kappa = \vec{E}_0 + \vec{E}_b.$$

Since these fields \vec{E}_0 and \vec{E}_b are always in opposite directions, the magnitude of \vec{E}_κ is always the difference of their magnitudes, and in the direction of the free space field. For any case we consider in this class \vec{E}_0 is always larger.

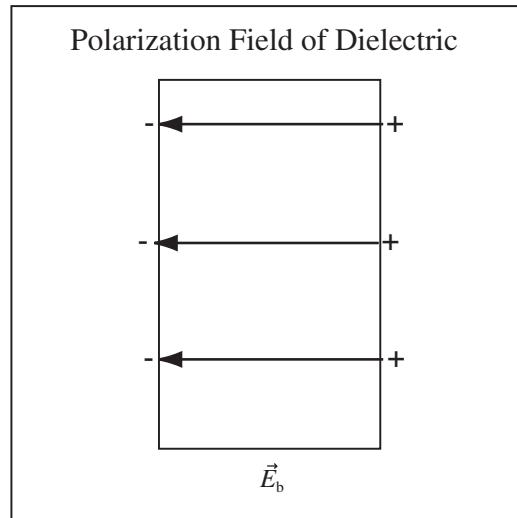

Example 13.5 Computing Dielectric Properties

Problem: A pane of glass (dielectric constant $\kappa = 5.6$) is placed in an electric field with magnitude $|\vec{E}_0| = 10000$ N/C directed normal to its surface.

- Compute the electric field inside the dielectric.
- Compute the electric field of the bound charge.
- Compute the bound charge density at the surface of the glass.
- Explain where in the world this charge comes from.

Solution to Part(a)

The dielectric reduces the field by a factor of κ , so the electric field in the dielectric is

$$|\vec{E}_\kappa| = \frac{|\vec{E}_0|}{\kappa} = 1785.7 \frac{\text{N}}{\text{C}}$$

in the same direction as \vec{E}_0 .

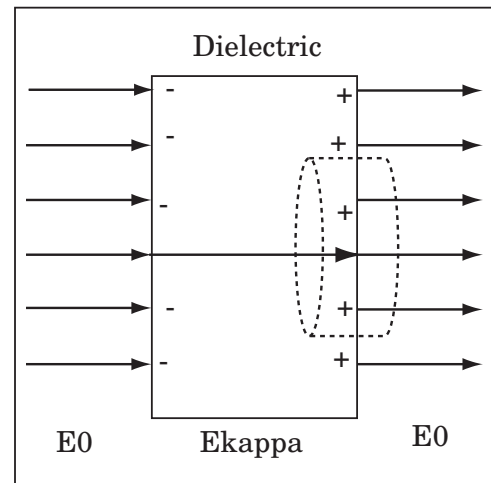

Solution to Part(b)

The bound charge produces an electric field which partially cancels \vec{E}_0 to produce \vec{E}_κ . This is why the electric field is reduced in the dielectric. Therefore, $|\vec{E}_b| = |\vec{E}_0| - |\vec{E}_\kappa| = 10000 \frac{\text{N}}{\text{C}} - 1785.7 \frac{\text{N}}{\text{C}} = 8214.3 \frac{\text{N}}{\text{C}}$. The bound field points in the opposite direction to \vec{E}_0 .

Solution to Part(c)

Using a Gaussian cylinder with end area A at the right surface of the dielectric, we find

$$\phi_e = AE_{right} - AE_{left} = \frac{Q_{enclosed}}{\epsilon_0}$$

where $E_{right} = E_0$ is the magnitude and sign of the field on the right surface and $E_{left} = E_\kappa$ is the magnitude and sign of the electric field on the left surface. Let the dielectric slab lie in the $y-z$ plane and let $+x$ be to the right.

$$E_{right}A - E_{left}A = \frac{Q_{enclosed}}{\epsilon_0} = \frac{\sigma_b A}{\epsilon_0}$$

$$\sigma_b = \epsilon_0(E_{right} - E_{left}) = \epsilon_0\left(E_0 - \frac{E_0}{\kappa}\right) = \epsilon_0 E_0 \left(1 - \frac{1}{\kappa}\right)$$

Cancelling A yields, Therefore, the bound charge density is

$$\sigma_b = \epsilon_0 E_0 \left(1 - \frac{1}{\kappa}\right) = (8.85 \times 10^{-12} \frac{\text{C}^2}{\text{Nm}^2})(10000 \frac{\text{N}}{\text{C}}) \left(1 - \frac{1}{5.6}\right) = 72.7 \frac{\text{nC}}{\text{m}^2}$$

Solution to Part(d)

The individual atoms or molecules polarize throughout the material, mostly cancelling in the middle, but leaving a little "extra" charge on each surface.

13.5 Superposition

The response of both a planar conductor and a planar dielectric to an external electric field was to generate equal and opposite planes of surface charge. The field is zero in a planar conductor because the field of the induced surface charge exactly cancels. To use this observation, we will need to understand the field of equal and opposite planar charges.

Consider the two fixed planes of charge shown below. The left plane has surface charge density $+\sigma$ and the right plane surface charge density $-\sigma$. If a cylindrical Gaussian surface with end area A encloses all the charge of the system, the charge enclosed is $Q_{enc} = (\sigma + (-\sigma))A = 0$. Therefore the field in region *I* and *III* is zero. A Gaussian surface that encloses only the left plane encloses a charge of $Q_{enc} = \sigma A$. Applying Gauss' law to this surface yields,

$$E_{II}A - E_I A = \frac{Q_{enc}}{\epsilon_0} = \frac{\sigma A}{\epsilon_0}$$

Since $E_I = 0$, this can be solved to yield $E_{II} = \sigma/\epsilon_0$.

Electric Field of Equal and Opposite Charge Densities:

The electric field of infinite planes of charge with equal and opposite charge densities, $+\sigma$ and $-\sigma$ is

$$\vec{E}_{II} = \frac{\sigma}{\epsilon_0} \hat{x}$$

between the planes and

$$\vec{E}_I = \vec{E}_{III} = 0$$

outside of the planes.

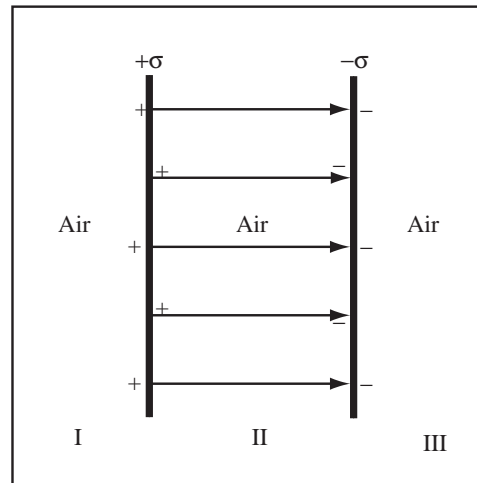

The electric fields of the infinite parallel planes can be added to an external field. Since the electric field outside of the planes is zero, the charges on the planes do not change the external field except in the region between the planes. Therefore, to calculate the electric field of a planar conductor we add the applied field to the field of the equal and opposite surface charges.

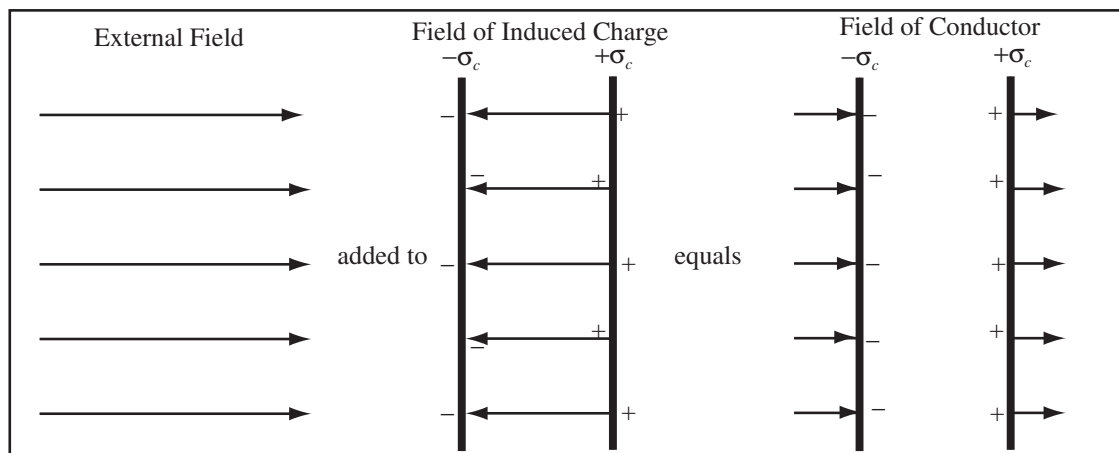

Example 13.6 Charge Density Required For Zero Field Between Planes

Problem: An external charge density (not drawn in the problem) produces a uniform electric field $\vec{E}_0 = E_0 \hat{x}$ where $E_0 > 0$. Two infinite parallel planes with equal and opposite charge densities $|\sigma|$ are placed in the field as shown to the right. Calculate σ_{left} and σ_{right} such that the electric field between the planes is zero.

Solution

(a) Draw the Field Map: We are given that the applied field is uniform and that the equal and opposite parallel planes of charge create a field that cancels the external field producing zero field between the planes. Therefore, to draw the field map we draw a uniform field outside the planes and zero field between the planes, as shown above. Draw + charges where lines begin and - charges where lines end.

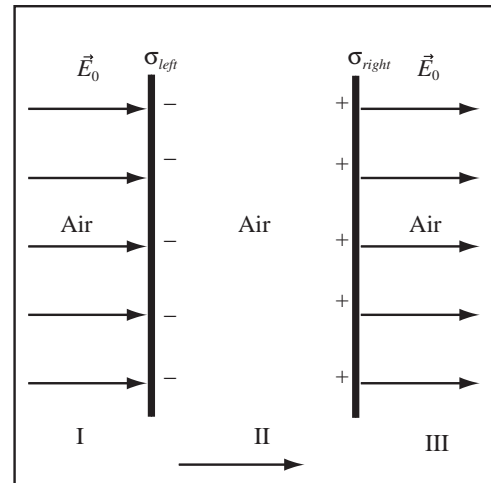

(b) Use the Field Map to Deduce the Charge Densities: Observing the field map, we see that the left plane must have a negative surface charge density $\sigma_{left} < 0$ and the right plane a positive surface charge density $\sigma_{right} > 0$. The planes are equal and opposite so $\sigma_{left} = -\sigma_{right}$.

(c) Reason About Field Produced by the Planes: The applied field is $\vec{E}_0 = E_0\hat{x}$ and it points in the positive \hat{x} direction. The total electric field between the planes is zero, therefore the electric field of the planes in the region between the planes, $\vec{E}_{planes,II}$, must satisfy

$$\vec{E}_0 + \vec{E}_{planes,II} = 0,$$

therefore the electric field between the planes must point in the negative \hat{x} direction. Let $\vec{E}_{II,planes} = E_{II,planes}\hat{x}$. From this we conclude

$$E_{II,planes} = -E_0$$

(d) Use the Field of Parallel Planes: The magnitude of the electric field between TWO infinite parallel planes of charge is

$$|E_{planes,II}| = \left| \frac{\sigma_{right}}{\epsilon_0} \right| = \left| \frac{\sigma_{left}}{\epsilon_0} \right|$$

Therefore,

$$\sigma_{right} = -\sigma_{left} = \epsilon_0 E_0$$

I used the analysis of the signs of the charge densities to correctly set the signs.

(e) Check Against Our Formula for Surface Charge Density: In the previous section, we derived a formula for surface charge density at a plane surface

$$\sigma_{left} = \epsilon_0(E_{II} - E_I) = \epsilon_0(0 - E_0) = \epsilon_0 E_0$$

so viewing the problems as a superposition of plane charges is consistent with using a Gaussian pillbox.

We can do the same analysis for a dielectric slab.

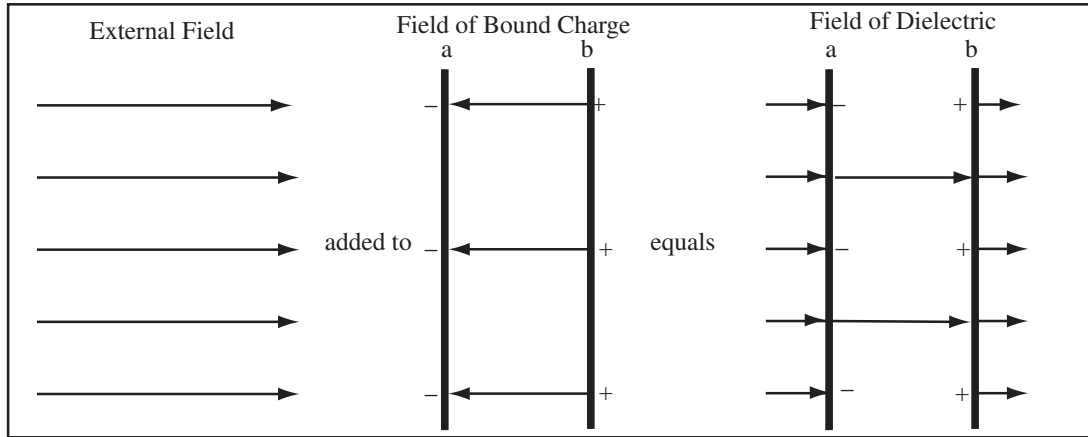

Example 13.7 Charge Density Required for Reduced Field between Parallel Planes

Problem: An external charge density (not drawn in the problem) produces a uniform electric field $\vec{E}_0 = E_0\hat{x}$ where $E_0 > 0$. Two infinite parallel planes with equal and opposite charge densities $|\sigma|$ are placed in the field. Calculate σ_{left} and σ_{right} such that the electric field between the planes is reduced by a factor of $\kappa = 2$.

Solution

(a) Draw the Field Map: We are given that the applied field is uniform and that the equal and opposite parallel planes of charge create a field that reduces the external field by a factor of 2 between the planes. Therefore, to draw the field map we draw a uniform field outside the planes and a field with half the number of lines between the planes, as shown above. Draw + charges where lines begin and - charges where lines end.

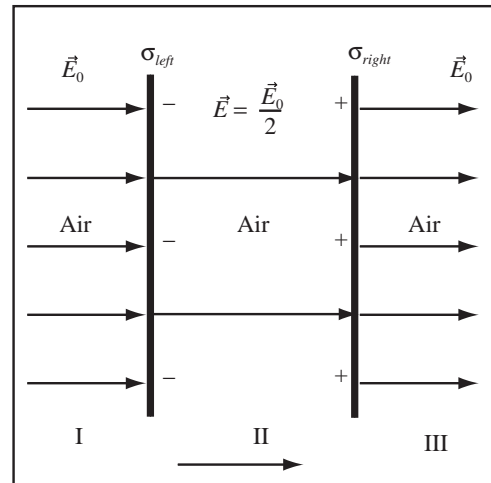

(b) Deduce the Sign of the Charge on Each Plane: Observing the field map, we see that the left plane must have a negative surface charge density $\sigma_{left} < 0$ and the right plane a positive surface charge density $\sigma_{right} > 0$. The planes are equal and opposite so $\sigma_{left} = -\sigma_{right}$.

(c) Reason About Field Produced by the Planes: The applied field is $\vec{E}_0 = E_0\hat{x}$ and it points in the positive \hat{x} direction. The total electric field between the planes is $\vec{E}_0/\kappa = \vec{E}_0/2$, therefore the electric field between the planes, $\vec{E}_{planes,II}$, must satisfy

$$\vec{E}_0 + \vec{E}_{planes,II} = \frac{\vec{E}_0}{\kappa}$$

The electric field of the planes, between the planes, must point in the negative \hat{x} direction. Let $\vec{E}_{II,planes} = E_{II,planes}\hat{x}$.

$$E_0 + E_{planes,II} = \frac{E_0}{\kappa}$$

From this we conclude

$$E_{II,planes} = -E_0 + \frac{E_0}{\kappa} = -E_0\left(1 - \frac{1}{\kappa}\right)$$

(d) Use the Field of Parallel Planes: The magnitude of the electric field between TWO infinite parallel planes of charge is

$$|E_{planes,II}| = \left| \frac{\sigma_{right}}{\epsilon_0} \right| = \left| \frac{\sigma_{left}}{\epsilon_0} \right|$$

$$|E_{planes,II}| = E_0 \left(1 - \frac{1}{\kappa} \right) = \frac{\sigma_{right}}{\epsilon_0} = -\frac{\sigma_{left}}{\epsilon_0}$$

Therefore,

$$\sigma_{right} = -\sigma_{left} = \epsilon_0 E_0 \left(1 - \frac{1}{\kappa} \right)$$

or substituting $\kappa = 2$,

$$\sigma_{right} = -\sigma_{left} = \frac{\epsilon_0 E_0}{2}$$

(e) Check Against Our Formula for Surface Charge Density: In the previous section, we derived a formula for surface charge density at a plane surface

$$\sigma_{left} = \epsilon_0 (E_{II} - E_I) = \epsilon_0 \left(\frac{E_0}{\kappa} - E_0 \right) = -\epsilon_0 E_0 \left(1 - \frac{1}{\kappa} \right)$$

so viewing the problems as a superposition of plane charges is consistent with using a Gaussian pillbox.

Chapter 14

High Symmetry Systems II

14.1 Field Maps

14.1.1 Adding a Conductor to a Symmetric Field Map

The fact we don't know where all the charge is screws everything up. The only systems where we can actually calculate the field with conductors and dielectrics are the high symmetry systems where we can use Gauss' as a calculation tool. We played with planar systems some in Course Guide 13 and found that while the field in the conductor and dielectric is different than the applied field, the applied field is unchanged outside of the material. This observation can be generalized to the other high symmetry systems.

Field Unchanged Outside of High Symmetry Conductor and Dielectric: If an uncharged conductor or dielectric with the same symmetry is placed in the field of a system of fixed charge with planar, cylindrical, or spherical symmetry, then the field is unchanged outside the conductor or dielectric. The field in the conductor is naturally zero and the field in the dielectric is \vec{E}_0/κ where \vec{E}_0 is the field of the fixed charge only.

The electric field in a conductor is zero. To add an uncharged conductor to a field map of a system with spherical, planar, or cylindrical symmetry, erase the lines in the conductor and draw + charges where lines end and - charges where lines begin. To add a charged conductor to a field map, redraw from scratch using Gauss' Law (Version 0). I am sorry that the stupid charge can move in a conductor, that just ruins everything.

Example 14.1 Add an Uncharged Conductor to a Parallel Plane Field Map

Problem: An infinite plane of charge with uniform charge density $\sigma_1 > 0$ occupies the $y - z$ plane through the origin. A parallel plane through $x = 1\text{cm}$ has charge density $\sigma_2 = -\sigma_1/2$. An uncharged conducting slab of thickness 0.33cm is placed between the slabs. Draw the electric field.

Solution

Draw the field map ignoring the conductor based on a calculation of the field strength. Sketch in the location of the conductor. Erase all field lines in the conductor. Draw charge where field lines begin and end.

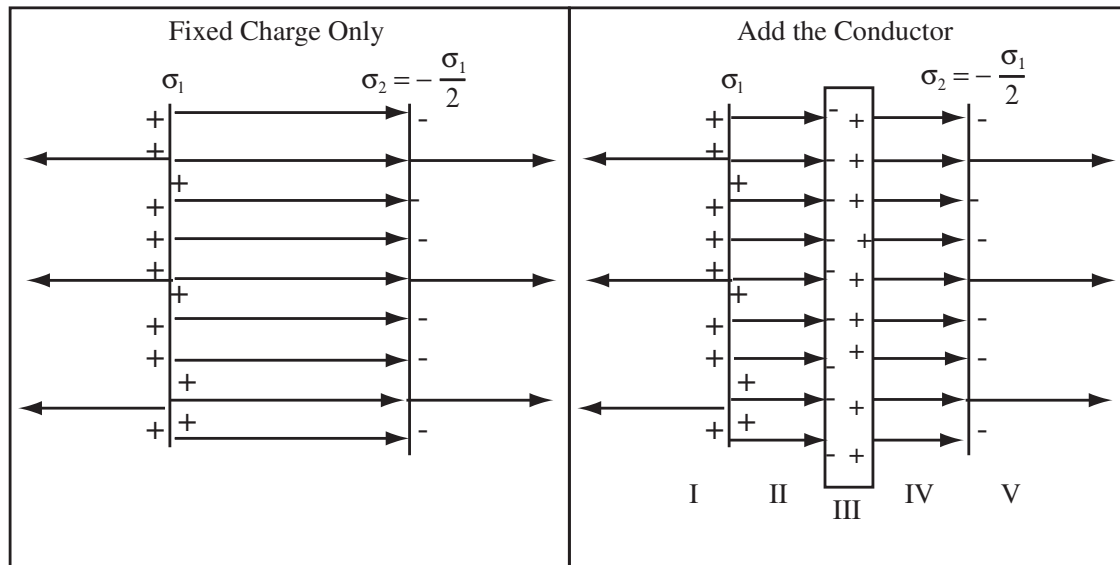

14.1.2 Adding a Dielectric to a Symmetric Field Map

A dielectric reduces the magnitude of the electric field by a factor of κ . To add an uncharged dielectric to a field map, simply erase enough lines to reduce the strength of the field by a factor of κ . If the dielectric is charged, the charge will be on the surface and can be treated as another fixed charge density. The best way to handle this situation is to imagine separating the net charge from the dielectric and treating the two separately.

Example 14.2 Add an Uncharged Dielectric to a Parallel Plane Field Map

Problem: An infinite plane of charge with uniform charge density σ_1 occupies the $y-z$ plane through the origin. A parallel plane through $x = 1\text{cm}$ has charge density $\sigma_2 = -\sigma_1/2$. An uncharged dielectric slab of thickness 0.33cm and dielectric constant $\kappa = 3$ is placed between the planes. Draw the electric field.

Solution

(a) Draw the Field Map Ignoring the Dielectric: This is the same fixed charge system as the previous example. Draw the field map ignoring the dielectric.

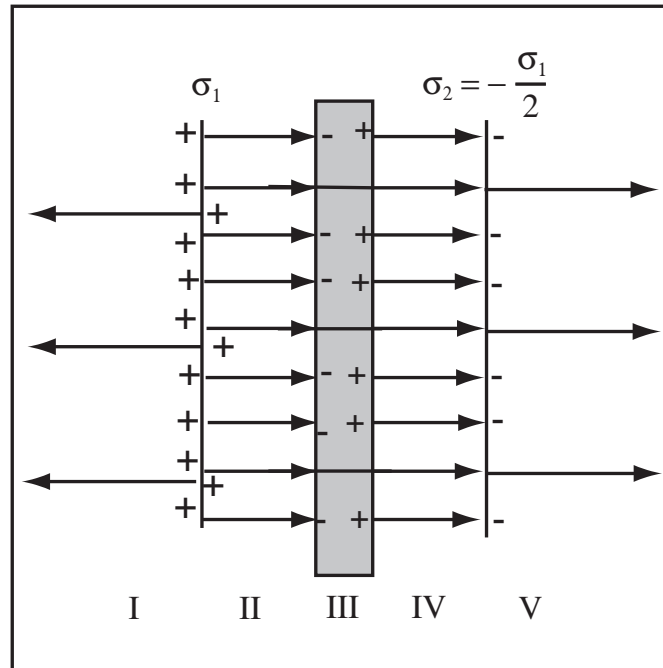

(b) Fix the Field Map Interior to the Dielectric: Now add the dielectric and thin the lines by a factor of $\kappa = 3$, so only three lines cross the dielectric. Draw charges where field lines begin and end.

Example 14.3 Drawing a Spherical Field Map with a Dielectric

Problem: If a thick dielectric shell has dielectric constant $\kappa = 2.0$ and surrounds a point charge of charge $+Q$, draw the electric field map using 8 field lines per $+Q$.

Solution

The dielectric thins the field lines by a factor of $\kappa = 2$, so eliminate half the field lines in the dielectric. Since the dielectric is uncharged, the same number of field lines must leave the dielectric as leave the central charge. Draw $+$ charge where lines begin and $-$ charge where lines end.

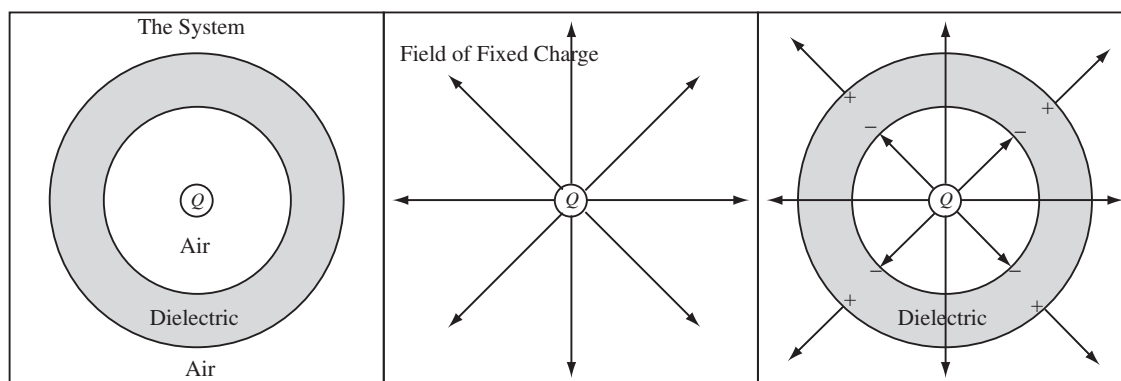

14.2 Electric Field

Using the same kind of reasoning we used for drawing electric field maps, we can compute the electric field and the induced and bound charge using Gauss' Law. The addition of an uncharged conductor or dielectric to a

highly symmetric system where Gauss' Law is useful for computing the field proceeds in the same way for both objects. We work the problem as we did in the static system and then correct the electric fields for the presence of the object, setting the field to zero inside a conductor and dividing the field by κ inside an insulator. As the Gaussian surface is moved from region to region, Gauss' Law allows the calculation of the induced charges on the conductors and the bound charges on the dielectrics.

Adding an Uncharged Conductor: To work a problem with an uncharged conductor, work the problem without the conductor, then draw the conductor in, erasing the field lines inside. The electric field inside the conductor is zero, the electric field outside the conductor is unchanged. The induced surface charge can be computed at each surface by applying Gauss' Law and requiring the field to be zero in the conductor.

Adding an Uncharged Dielectric: To work a problem with an uncharged dielectric, we work the problem without the dielectric, then draw the dielectric in. The electric field inside the dielectric is \vec{E}/κ , where \vec{E} is the field we calculated with no dielectric and κ is the dielectric constant. The electric field outside the dielectric is unchanged. The bound surface charge can be computed at each surface by using Gauss' Law, with the requirement that it produces the correct dielectric field.

Example 14.4 Gauss' Law with Conductors and Dielectric but no Surface Charge

Problem: A point charge with charge Q is surrounded by an uncharged dielectric shell with dielectric constant, κ , and an uncharged conductor as shown below.

- Compute the electric field in region I.
- Compute the electric field in region II.
- Compute the electric field in region III.
- Compute the electric field in region IV.
- Compute the electric field in region V.

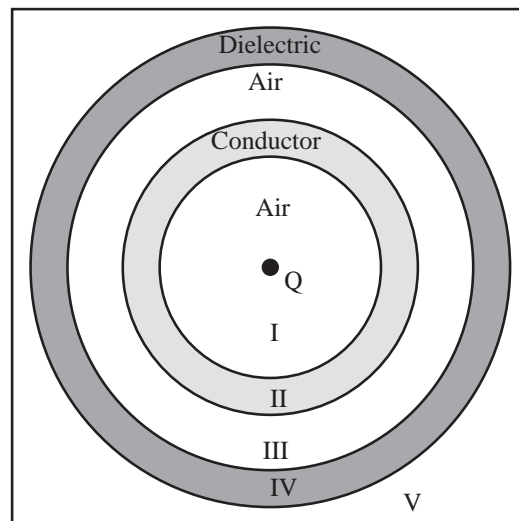

Solution to Part (a)

For a system of charge with spherical symmetry, Gauss' Law can be simplified to

$$\vec{E} = \frac{Q_{\text{enclosed}}}{4\pi\epsilon_0 r^2} \hat{r}.$$

The only net charge in the system is the point charge, since neither the conductor nor the dielectric have net charge. The electric field of the point charge, either using Gauss' Law or Coulomb's Law, is

$$\vec{E} = \frac{Q}{4\pi\epsilon_0 r^2} \hat{r}.$$

The conductor and dielectric only modify this field in their interior, so in regions I, III, and V, the total charge enclosed is Q and the electric field is

$$\vec{E}_I = \frac{Q}{4\pi\epsilon_0 r^2} \hat{r}.$$

Solution to Part (b)

The electric field in region *II* is zero, because we are in a conductor.

$$\vec{E}_{II} = 0$$

Solution to Part (c)

The electric field in region *III* is outside of the conductor and dielectric and is unchanged from the point charge field.

$$\vec{E}_{III} = \frac{Q}{4\pi\epsilon_0 r^2} \hat{r}$$

Solution to Part (d)

The electric field in region *IV* is the electric field in the region if no dielectric were present, divided by κ , the dielectric constant. Therefore,

$$\vec{E}_{IV} = \frac{Q}{4\pi\epsilon_0 \kappa r^2} \hat{r}.$$

Solution to Part (e)

A Gaussian surface in region *V* is outside of all charge and encloses a total charge of Q , therefore the electric field in region *V* is

$$\vec{E}_V = \frac{Q}{4\pi\epsilon_0 r^2} \hat{r}.$$

The next step is to learn how to add a charged conductor to a highly symmetric system of charge. This presents a big problem. In every other case, we have known where the net charge is. In this case, the net charge can move from side to side in the conductor and we have to use Gauss' law to figure out where it is. The first example uses only conductors and the second example throws a dielectric into the mix.

Example 14.5 Charged Spherical Conductor

Problem: A spherical conductor with radius a has net charge Q . The conductor is surrounded by a thick conducting shell with inner radius b and outer radius c which has total charge $-Q/3$. Compute the electric field everywhere and all surface charge densities.

Solution

(a) Draw a Good Diagram: Let the inner conductor be conductor 1 and the outer shell be conductor 2. Select 6 lines per Q . The total charge in a spherical Gaussian surface in region *II* as drawn is $Q_{enc} = Q$, so by Gauss' Law version 0, 6 lines cross region *II*. Four lines cross region *IV* because the total charge enclosed by a Gaussian surface in region *IV* is $Q_{enc} = Q - Q/3 = 2Q/3$. Draw $-$ charge where lines end and $+$ charge where lines begin.

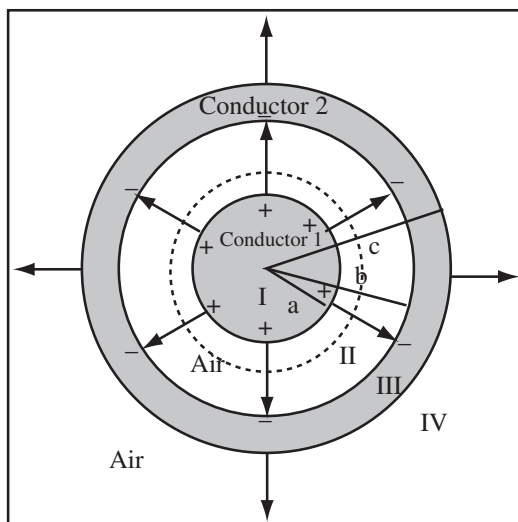

(b) Select Gauss' Law Appropriate for Symmetry: For spherical symmetry, the electric flux out of a Gaussian surface of radius r is $4\pi r^2 E(r)$ and by Gauss' law

$$\phi_e = 4\pi r^2 E(r) = \frac{Q_{enc}}{\epsilon_0}$$

where Q_{enc} is the charge enclosed in a Gaussian surface of radius r .

(c) Compute the Electric Field in all Regions: The electric field in region *I* and region *III* is zero because of the conductors.

$$\vec{E}_I = \vec{E}_{III} = 0$$

The total charge enclosed by a Gaussian surface in region *II* is Q , therefore the electric field in region *II* is

$$\vec{E}_{II} = \frac{Q}{4\pi\epsilon_0 r^2} \hat{r}$$

The total charge enclosed by a Gaussian surface in region *IV* is $Q_{enc} = Q - Q/3 = 2Q/3$. Apply Gauss' Law

$$\vec{E}_{IV} = \frac{2Q/3}{4\pi\epsilon_0 r^2} \hat{r} = \frac{Q}{6\pi\epsilon_0 r^2} \hat{r}$$

(d) Compute the Surface Charge Density on Conductor 1: The net charge Q must be on the outer surface of conductor 1. The surface charge density on the outer surface of the inner conductor is

$$\sigma_1 = \frac{Q}{4\pi a^2}$$

(e) Compute the Surface Charge on the Inner Surface of Conductor 2: Place a Gaussian surface in region *III* as shown to the right. Since the electric field in this region is zero, the Gaussian surface must enclose zero net charge. A Gaussian surface in region *III* encloses the charge on the inner conductor and the charge on the inner surface of the conducting shell, $Q_{2,in}$. Therefore, $Q_{2,in} + Q = 0$ or $Q_{2,in} = -Q$. Divide by the area of the inner surface to get the charge density,

$$\sigma_{2,in} = \frac{-Q}{4\pi b^2}.$$

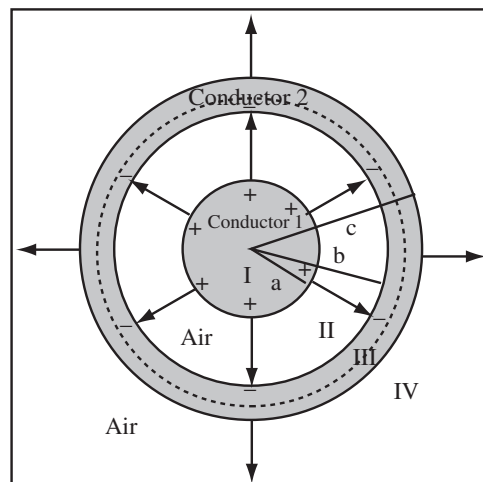

(f) Compute the Surface Charge Density on the Outer Surface of Conductor 2: The total charge on conductor 2 must be $-Q/3$ which must be the sum of the charge on the inner surface and the charge on the outer surface,

$$\frac{-Q}{3} = Q_{2,in} + Q_{2,out} = -Q + Q_{2,out}$$

therefore

$$Q_{2,out} = \frac{2Q}{3}$$

The charge density on the outer surface of the conducting shell is

$$\sigma_{2,out} = \frac{Q_{2,out}}{4\pi c^2} = \frac{Q}{6\pi c^2}$$

Example 14.6 Spherical Gauss's Law with Conductor and Dielectric

Problem: A point charge with charge $+Q$ is surrounded by a charged conducting shell, with total charge $-2Q$, of inner radius a and outer radius b . Outside of the shell is an uncharged dielectric shell of inner radius b and outer radius c , with dielectric constant $\kappa = 3$.

- What is the field in region I?
- What is the field in region II?
- What is the field in region III?
- What is the field in region IV?
- What is the charge on inner surface of the conductor $Q_{c,inner}$?
- What is the charge on the outer surface of the conductor $Q_{c,outer}$?
- What is the bound charge on the inner surface of the dielectric $Q_{d,inner}$?
- What is the bound charge on the outer surface of the dielectric $Q_{d,outer}$?

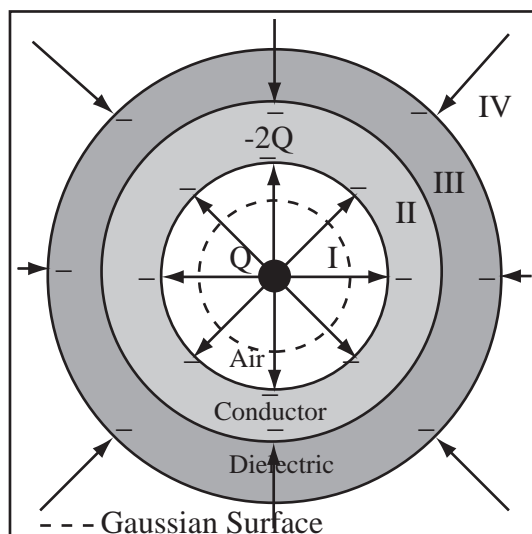
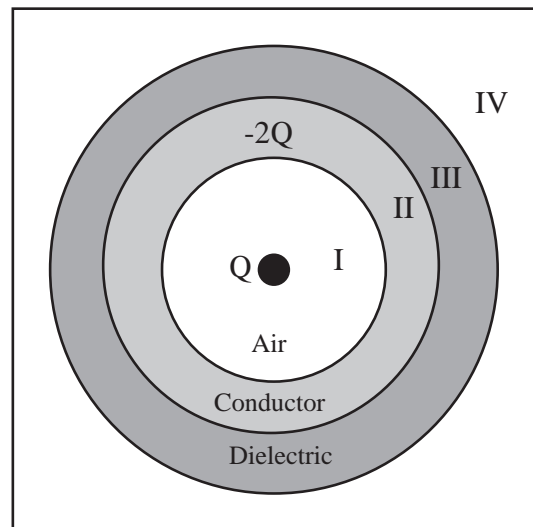

Definitions

$\vec{E}_i \equiv$ Electric field in Region i

$\vec{r} \equiv$ Radius vector.

$Q \equiv$ Central Charge

$Q_{c,inner} \equiv$ Total charge on inner surface of conductor

$Q_{c,outer} \equiv$ Total charge on outer surface of conductor

$Q_{d,inner} \equiv$ Total charge on inner surface of dielectric

$Q_{d,outer} \equiv$ Total charge on outer surface of dielectric

$\kappa = 3 \equiv$ Dielectric Constant

Strategy: Use result of Gauss' Law for spherical symmetry in each region. Figure out bound charges from the change in field across material boundaries.

Solution to Part (a)

(a) Draw a Good Diagram: All field lines are radial. I chose 8 lines going out for the central Q . All these lines end on the conductor. If the dielectric was not present a Gaussian surface outside the conductor would contain a total charge of $-Q$, so in region IV there are 8 lines going in. The dielectric thins the lines by a factor of κ , so in the dielectric there are $8/3 \approx 2$ lines going in. Draw charge where lines begin and end.

(b) Compute \vec{E}_I : By Gauss' Law, the electric field of a spherically symmetric charge distribution is

$$\vec{E} = \frac{Q_{\text{enclosed}}}{4\pi\epsilon_0 r^2} \hat{r}$$

In region I, the total charge enclosed is Q , so

$$\vec{E}_I = \frac{Q}{4\pi\epsilon_0 r^2} \hat{r}$$

Solution to Part (b)

Compute \vec{E}_{II} : In region II, we are inside

$$\vec{E}_{II} = 0$$

Solution to Part (c)

Compute \vec{E}_{III} : In region III, the electric field would be the same as region IV if no dielectric were present. The dielectric thins the fixed charge field by a factor of κ , so

$$\vec{E}_{III} = \frac{\vec{E}_{IV}}{\kappa} = \frac{-Q}{4\pi\epsilon_0 \kappa r^2} \hat{r}$$

Solution to Part (d)

Compute \vec{E}_{IV} : In region IV, the total charge enclosed is $-Q = Q - 2Q$, so

$$\vec{E}_{IV} = \frac{-Q}{4\pi\epsilon_0 r^2} \hat{r}$$

Solution to Part (e)

Compute Induced Charge on Conductor: Since the electric field is zero in the conductor a Gaussian surface in the conductor encloses zero charge. The charge enclosed by a Gaussian surface in the conductor is the central charge, Q , plus the induced charge on the inner surface of the conductor $Q_{c,inner}$, so $Q + Q_{c,inner} = 0$, or

$$Q_{c,inner} = -Q$$

Solution to Part (f)

The total charge of the conductor is $-2Q$, which must be the sum of the inner and outer charge densities on the conductor, so $-2Q = Q_{c,inner} + Q_{c,outer}$ and solving

$$Q_{c,outer} = -Q$$

Solution to Part (g)

Compute Bound Charge on the Dielectric: The field in the dielectric is $\vec{E}_{III} = \frac{\vec{E}_{IV}}{\kappa} = \frac{-Q}{4\pi\epsilon_0\kappa r^2}\hat{r}$, but in the dielectric this must be the field from the total charge enclosed which is $Q_{enclosed} = Q - 2Q + Q_{d,inner}$, which by Gauss' Law give a field of $\vec{E} = \frac{Q_{enclosed}}{4\pi\epsilon_0 r^2}\hat{r}$. Comparing these two expressions we get,

$$Q_{enclosed} = -\frac{Q}{\kappa} = -\frac{Q}{3} = Q - 2Q + Q_{d,inner}.$$

Solving gives

$$Q_{d,inner} = \frac{2}{3}Q$$

Solution to Part (h)

The dielectric is uncharged so $Q_{d,inner} + Q_{d,outer} = 0$, or

$$Q_{d,outer} = -\frac{2}{3}Q$$

The same methods can be applied to planar symmetry.

Example 14.7 Parallel Planes with Uncharged Dielectric and Conductor

Problem: A uncharged conducting slab and an uncharged dielectric slab with dielectric constant, κ , have thickness 1cm and are spaced 1cm apart. Immediately between them is a sheet of charge with charge density, σ .

- (a) Use Gauss' Law to find the electric field everywhere.
 (b) Compute any surface charge densities.

Solution to Part(a)

(a) Draw the field map: The electric field of an isolated plane of charge points directly outward from the plane. The plane charge is the only fixed charge in the system, so outside of the conductor and dielectric the field is that of the plane. Correct the field for the conductor and dielectric. Outside of an uncharged conductor or dielectric in a high symmetry system, the field is unchanged.

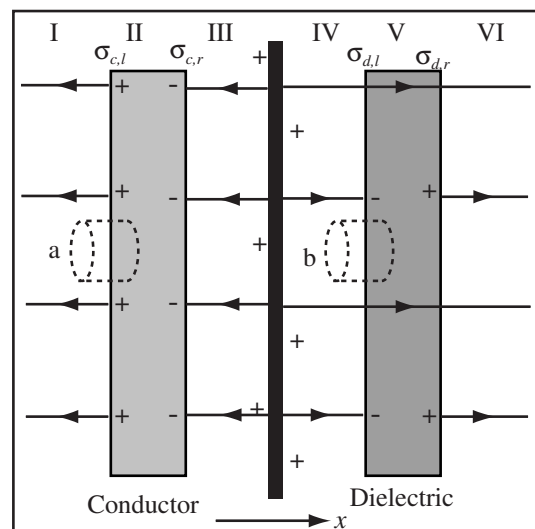

(b) Compute the Field Outside the Conductor and Dielectric: The electric field of an isolated plane of charge is $\frac{-\sigma}{2\epsilon_0}\hat{x}$ if $x < 0$ and $\frac{\sigma}{2\epsilon_0}\hat{x}$ if $x > 0$. Therefore, we can immediately write the field in regions I, III, IV, VI since they are outside of the conductor and dielectric.

$$\vec{E}_I = \vec{E}_{III} = -\frac{\sigma}{2\epsilon_0}\hat{x}$$

$$\vec{E}_{IV} = \vec{E}_{VI} = \frac{\sigma}{2\epsilon_0} \hat{x}.$$

(c) Correct the Fields in the Conductor and the Dielectric: The electric field in the conductor is zero, $\vec{E}_{II} = 0$. The electric field in the dielectric is reduced by a factor of κ from the field that would exist if no dielectric were present.

$$\vec{E}_V = \frac{\sigma}{2\epsilon_0\kappa} \hat{x}$$

Solution to Part(b)

(a) Select an Appropriate Gaussian Surface: Use the cylindrical Gaussian surfaces drawn which enclose the left surface of the conductor, a , and the left surface of the dielectric, b .

(b) Apply Gauss' Law to Surface a : If surface a has end area A , the charge enclosed is $\sigma_{c,\ell}A$. By Gauss' Law,

$$E_{II}A - E_I A = \frac{Q_{enc}}{\epsilon_0} = \frac{\sigma_{c,\ell}A}{\epsilon_0}$$

Since $E_{II} = 0$,

$$-E_I = \frac{\sigma_{c,\ell}}{\epsilon_0}$$

$$\sigma_{c,\ell} = -\epsilon_0 E_I = \frac{\sigma}{2}.$$

(c) Conserve Charge on Conductor: Since the conductor is uncharged, $\sigma_{c,\ell} + \sigma_{c,r} = 0$, therefore

$$\sigma_{c,r} = \epsilon_0 E_I = \frac{-\sigma}{2}$$

Notice the signs of the charge density match the signs of the charges you drew in the figure.

(d) Apply Gauss' Law to Surface b : The total charge enclosed in surface b , if it has end area A , is $Q_{enc} = \sigma_{d,\ell}A$. Apply Gauss' Law,

$$E_V A - E_{IV} A = \frac{Q_{enc}}{\epsilon_0} = \frac{\sigma_{d,\ell}A}{\epsilon_0}$$

$$\frac{\sigma}{2\epsilon_0\kappa} - \frac{\sigma}{2\epsilon_0} = \frac{\sigma_{d,\ell}}{\epsilon_0}$$

$$\sigma_{d,\ell} = \frac{\sigma}{2} \left(\frac{1}{\kappa} - 1 \right).$$

(e) Conserve Charge on the Dielectric: Since the dielectric is uncharged, $\sigma_{d,\ell} + \sigma_{d,r} = 0$.

$$\sigma_{d,r} = -\frac{\sigma}{2} \left(\frac{1}{\kappa} - 1 \right) = \frac{\sigma}{2} \left(1 - \frac{1}{\kappa} \right)$$

Finally, an example of working a problem in cylindrical symmetry.

Example 14.8 Cylindrical Gaussian Surface with Volume Charge

Problem: A charge is distributed with a uniform charge density, $+\rho$ throughout a solid rod of radius c , centered on the \hat{z} axis. Compared to the distances we wish to find the field for, the rod is very long, so you may assume it is infinite.

- Using Gauss' Law, find the formulae for the electric field for all points inside and outside of the rod.
- A cylindrical conducting shell, centered on the \hat{z} axis, of inner radius a and outer radius b is placed surrounding the rod. It carries a charge per unit length $-\lambda$. What is the surface charge density on the inner surface of the shell?
- What is the surface charge density on the outer surface of the shell?
- Assume $\pi c^2 \rho < |\lambda|$. Draw the electric field lines for all regions on the figure. Emphasize important properties of the fields.

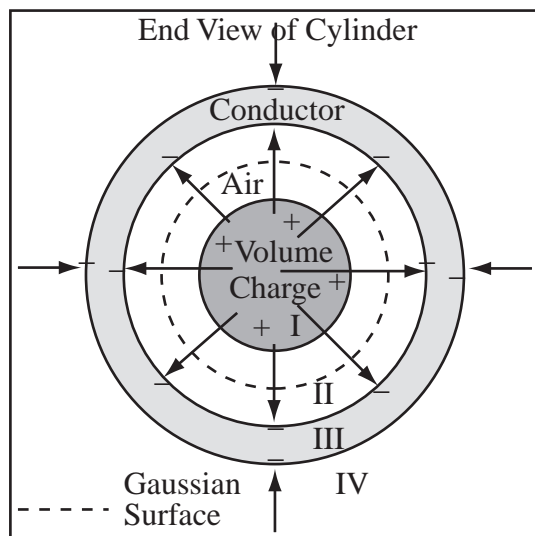

Definitions

$Q_c \equiv$ Charge of Conductor

$Q_v(r) \equiv$ Charge Enclosed in Volume at radius r

$L \equiv$ Arbitrary Length of Objects

$\vec{E}_i \equiv$ Electric Field in Region i

$\vec{r} \equiv$ Radius Vector

$c \equiv$ Radius of charged cylinder

$-\lambda \equiv$ Charge per unit length on conductor

$a \equiv$ Inner radius of conductor

$b \equiv$ Outer radius of conductor

Solution to Part (a)

(a) Derive a General Expression for Gauss' Law in Cylindrical Symmetry: Select a Gaussian surface that is a cylinder co-axial with the \hat{z} axis or radius r and length L . The electric flux out of the Gaussian surface is $\phi_e = 2\pi rLE(r)$ and applying Gauss' law

$$\phi_e = 2\pi rLE(r) = \frac{Q_{enc}}{\epsilon_0}$$

(b) Compute Electric Field in Region I: Now we apply our general result to each region. For any radius in region I, the Gaussian surface encloses charge $Q_v(r) = \pi r^2 \rho L$. Notice the charge enclosed changes with the radius. Substitute into the general expression for the field computed above

$$E_I(r) = \frac{\pi r^2 \rho L}{2\pi \epsilon_0 r L}$$

$$\vec{E}_I(r) = \frac{\rho r}{2\epsilon_0} \hat{r}$$

For any system where an arbitrary length L must be introduced, that L must cancel from the final answer, or else you have done something very wrong.

(c) Compute Electric Field in Region II: In region II, the Gaussian surface always encloses all the volume charge $Q_v(c) = \pi c^2 \rho L$. Substitute:

$$E_{II}(r) = \frac{\pi c^2 \rho L}{2\pi \epsilon_0 r L}$$

$$\vec{E}_{II}(r) = \frac{c^2 \rho}{2\epsilon_0 r} \hat{r}$$

When the conductor is not present this is the field at all points outside of the volume charge.

(d) Compute Electric Field in Region III: The electric field inside the conductor is zero for static systems.

$$\vec{E}_{III}(r) = 0.$$

(e) Compute Electric Field in Region IV: In region IV the total charge enclosed by the Gaussian surface is $Q_{enclosed} = Q_v(c) + Q_c = \pi c^2 \rho L - \lambda L$. Substitute:

$$E_{IV}(r) = \frac{\pi c^2 \rho L - \lambda L}{2\pi \epsilon_0 r L}$$

$$\vec{E}_{IV}(r) = \frac{\pi c^2 \rho - \lambda}{2\pi \epsilon_0 r} \hat{r}$$

Solution to Part (b)

The electric field for the full system is computed above. In the conductor the field is zero, so by Gauss' Law the charge enclosed in a Gaussian surface in the conductor must be zero. The total charge enclosed is $Q_v(c) + \lambda_{c,inner}L = 0$ where $\lambda_{c,inner}$ is the charge per unit length on the inner surface of the conductor. Therefore,

$$\lambda_{c,inner} = -\pi c^2 \rho$$

To convert this to the surface charge density we divide the total charge on a length L of the inner surface, $\lambda_{c,inner}L$ by the surface area $2\pi aL$, giving

$$\sigma_{c,inner} = \frac{\lambda_{c,inner}}{2\pi aL} = \frac{c^2 \rho}{2a}$$

Solution to Part (c)

The total charge per unit length on the conductor is $-\lambda$ which is the sum of the charge on the inner and outer surfaces, the only place charge can be: $\lambda_{c,outer} + \lambda_{c,inner} = -\lambda$, so

$$\lambda_{c,outer} = \pi c^2 \rho - \lambda$$

As above we convert this to the surface charge density,

$$\sigma_{c,outer} = \frac{\lambda_{c,outer}}{2\pi bL} = \frac{\pi c^2 \rho - \lambda}{2\pi b}$$

Solution to Part (d)

We are given $\pi c^2 \rho < |\lambda|$, so $|Q_v| < |Q_c|$. This means that outside the conductor the net charge enclosed is negative so the field lines go in. Inside the conductor only positive charge is enclosed so field lines point outward. Since lines end on both the inside and outside of the conductor, there is negative charge on both surfaces. Using a dashed line, draw the general Gaussian surface on the diagram. The surface is a cylinder with length L . Its radius is r and its outward normal is \hat{r} .

Chapter 15

Non-Uniform Charge Densities

15.1 Non-Uniform Charge Densities

Our work with Gauss' law so far used only uniform charge densities. This sometimes lead to charge enclosed in the Gaussian surface that changed with the radius of the Gaussian surface, $Q_{enc}(r)$. Once the charge enclosed was calculated, the field could be immediately found by using a form of Gauss' law specialized for the symmetry. No new techniques are required to handle symmetric charge densities that change with position.

You may or may not recall the shell method from calculus, but the shell method gives the charge of a non-uniform spherical volume charge as:

Total Charge of a Radial Charge Distribution: If the volume charge density of a system, ρ , depends only on the distance from the origin and is confined to the interval $(0, R)$, then the total charge of the system, Q , is given by

$$Q = \int_0^R 4\pi r^2 \rho(r) dr$$

The formula above allows us to calculate the charge enclosed in a Gaussian surface for a non-uniform volume charge.

Example 15.1 Gauss' Law with a Non-Uniform Charge Density

Problem: A system of charge has spherical symmetry. For points $r < R$, the charge density is $\rho(r) = \rho_0 e^{-\frac{r}{a}}$ and zero for points $r > R$. Calculate the electric field everywhere.

Solution

(a) Draw the Field Map: Separate the system into two regions, one inside and one outside the charge. The field lines begin at various points throughout the volume charge. A sample Gaussian surface of radius r is drawn.

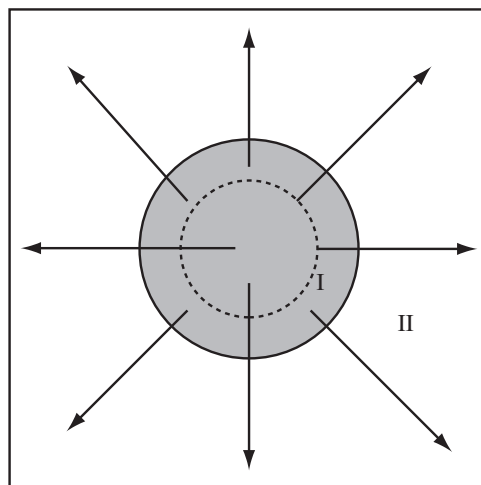

(b) Calculate the Field in Region I: A spherical surface of radius r encloses a charge of

$$Q_{enc}(r) = \int_0^r 4\pi r^2 \rho(r) dr = \int_0^r 4\pi r^2 \rho_0 e^{-\frac{r}{a}} dr = 4\pi \rho_0 \int_0^r r^2 e^{-\frac{r}{a}} dr$$

Look up the integral $\int r^2 \exp(-r/a) dr = -a \exp(-r/a)(a^2 + 2ar + r^2)$. Therefore

$$Q_{enc}(r) = -4\pi \rho_0 a \exp(-r/a)(a^2 + 2ar + r^2) \Big|_0^r = 4\pi \rho_0 a (a^2 - \exp(-r/a)(a^2 + 2ar + r^2))$$

Therefore, the field in region I is

$$\vec{E}_I(r) = \frac{Q_{enc}(r)}{4\pi \epsilon_0 r^2} \hat{r} = \frac{4\pi \rho_0 a (a^2 - \exp(-r/a)(a^2 + 2ar + r^2))}{4\pi \epsilon_0 r^2} \hat{r}$$

(c) Calculate the Electric Field in Region II: The total charge enclosed by any Gaussian surface in region II is

$$Q_{enc}(R) = 4\pi \rho_0 a (a^2 - \exp(-R/a)(a^2 + 2aR + R^2))$$

$$\vec{E}_{II}(r) = \frac{Q_{enc}(r)}{4\pi \epsilon_0 r^2} \hat{r} = \frac{4\pi \rho_0 a (a^2 - \exp(-R/a)(a^2 + 2aR + R^2))}{4\pi \epsilon_0 r^2} \hat{r}$$

Note the expression we got was ugly, but the physics we did was easy and the math we just looked up.

Chapter 16

Work and Energy

The course up to this point has presented a “force” picture of electrostatics. Our primary descriptive tool has been the electric field which is the force per unit charge. For many situations it is more powerful to analyze systems in terms of energy. This chapter reviews the energy concepts from UPI that we will need to understand electrostatic energy.

16.1 Force and Work

In high school, work was force times distance. We need to improve this somewhat. Consider the two objects, shown to the right. The objects are in contact at point P . Suppose object A exerts a force \vec{F}_{AB} on object B while the point P moves from point \vec{r}_1 to \vec{r}_2 . The displacement (movement) of point P is $\Delta\vec{r} = \vec{r}_{12} = \vec{r}_2 - \vec{r}_1$. The work done by object A on object B is $W_{AB} = \vec{F}_{AB} \cdot \Delta\vec{r}$. Likewise, the work object B does on object A during the displacement is $W_{BA} = \vec{F}_{BA} \cdot \Delta\vec{r} = -\vec{F}_{AB} \cdot \Delta\vec{r} = -W_{AB}$ by Newton's Third Law.

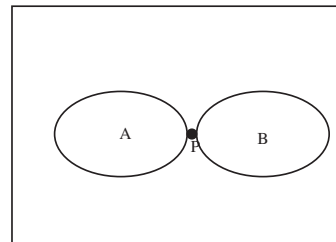

The sign of the work depends on the relative direction of the force and the direction the point the force applies moves. If the point P moves in the same direction as the force applied by A , then the work done by A is positive. This is the case when you try to push a box across the floor; the box moves in the same direction as the applied force and the work you exert is positive. If the point P moves the opposite direction to the direction of the force applied by A , then the work done by A is negative. This the case when you try to stop a box sliding toward you; you apply a force opposite to the direction of the box's motion, since it is still moving toward you until it is brought to a stop, therefore you do negative work on the box. We can generalize this definition of work to include forces that aren't constant.

Definition of Work: The work done by A to move object B along the curve C is

$$W_{AB} = \int_C \vec{F}_{AB} \cdot d\vec{r}$$

where F_{AB} is the force A exerts on B and $d\vec{r}$ points in the direction of the curve.

The integral in the definition of work is taken along the curve C . As usual to see where it comes from imagine cutting the curve below up into little pieces of length Δs . The vector $d\vec{r}$ points from one end to the other end of the small segment, as drawn below. The vector $d\vec{r}$ has length Δs and points in a direction tangent to the curve.

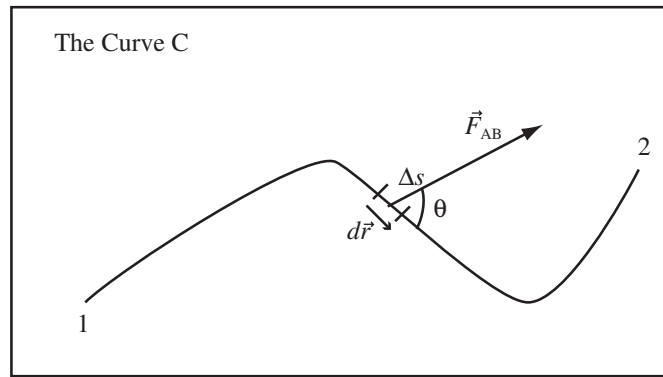

The component of force in the direction of motion is $F_{AB} \cos \theta$. The work done by A on B as it moves from point 1 to point 2 along the curve is

$$W_{AB} = \sum_i F_{AB} \Delta s \cos \theta_i = \sum_i \vec{F}_{AB} \cdot \Delta \vec{r}$$

This work is just the component of the force along the curve at each point multiplied the length of the curve.

16.2 Total Energy

Let's divide the universe into two pieces: the system and the environment. I usually imagine the system as a box and environment as everything outside of the box. The idea of a system is more general, any division of the universe where you can clearly say which objects are in the system and which objects are in the environment will do.

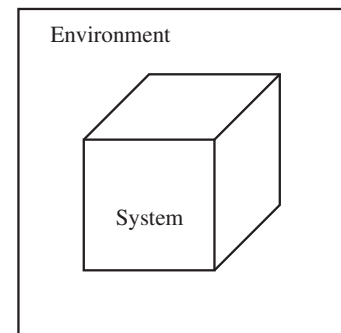

If two particles i and j are both in the system, then the forces between the particles, \vec{F}_{ij} and \vec{F}_{ji} , are called internal forces. If the particle i is in the environment and particle j is in the system, then we will call i an external agent and the force \vec{F}_{ij} , the force the external agent exerts on the system at point j or more briefly \vec{F}_{ij} is an external force.

Imagine building a system from scratch, starting from an empty box with all the particles that make up the system infinitely far apart. (With the particles scattered to the ends of the universe?) The person or thing, the external agent, who builds the system does so by exerting the force \vec{F}_i on each particle in turn needed to bring the particle in from infinity and place it where it goes in the system. If the particle is to have kinetic energy, the external agent then exerts some more force to give the particle the velocity it needs. It requires no work to move the first particle into the empty box, since there are no particles in the system to exert a force to resist the motion. The external agent must do work against the force of the first particle to place the second particle. Any system can be built up one particle at a time. Define the total energy, E_{TOT} , of the system as the total work to build it. Note I am using the symbol E_{TOT} for total energy not electric field.

Definition of Total Energy: The total energy of a system, E_{TOT} , is the total work required to build the system,

$$E_{TOT} = \sum_i W_i$$

where W_i is the work to place the i th particle in the presence of the particles $j < i$.

If the system is isolated, that is if there are no external forces acting on the system, then the total energy is constant.

Energy of an Isolated System is Conserved: The total energy of an isolated system is constant,

$$E_{TOT} = \text{constant}$$

If a system is not isolated, the external forces can change its total energy:

Conservation of Energy for a Non-Isolated System: If W is the total work done on a system by external forces, then the change in the total energy, ΔE_{TOT} , of the system is equal to the work done on the system

$$W = \Delta E_{TOT}$$

16.3 Kinetic and Potential Energy

The total energy of the system can be made up of energy of many forms; chemical, thermal, etc. We will restrict our discussion of energy to two forms; the energy of motion, called the kinetic energy, and the energy stored in the arrangement of the system, called potential energy.

16.3.1 Kinetic and Potential Energy

Focus on a single particle, i , of our system. The energy associated with the motion of the particle is the kinetic energy.

Definition of Kinetic Energy: The kinetic energy, K_i , of the particle i is

$$K_i = \frac{1}{2}m_i v_i^2 = \frac{1}{2}m_i \vec{v}_i \cdot \vec{v}_i$$

where m_i is the mass of the particle and \vec{v}_i its velocity.

The particle also has potential energy U_i , an energy associated with its relative placement in the system and the internal forces the other particles in the system exert. Potential energy is measured in reference to some point that is defined to have zero potential energy. To measure the potential energy of particle i , freeze all the other particles in place and measure the work to move particle i from the point of zero potential energy to the current position of the particle.

Definition of Potential Energy: The potential energy of the i th particle is the work an external agent would have to do to place it at its current position with all other particles already in place

$$U_i = W_i = \int_C \vec{F}_i \cdot d\vec{r}$$

where the curve C is path from the point of zero potential to its current location and \vec{F}_i the net force exerted by the external agent.

If there are no losses in the system and the other particles of the system are fixed, then the potential energy of particle i has a unique value at each point in space and can be written as a function of location, $U_i(x, y, z)$.

16.3.2 Conservation of Energy

If a potential energy function exists for a particle, then any increase in kinetic energy of particle i is balanced by a decrease in potential energy.

Conservation of Total Energy: If the potential and kinetic energy of the system fully accounts for the energy of the system and the system is isolated then the total energy is

$$E_{TOT} = \sum_i K_i + U = \text{constant}$$

where U is the total potential energy of the system defined as the work an external agent would do to build the system piece by piece, placing each particle at rest. The total energy of an isolated system is constant.

This is more general than we need for this class. In most cases we will only allow one of the particles in the system to move. Only that particle has kinetic energy and the potential energy of the system becomes the potential energy of the particle. In this case, we choose the zero of potential to absorb the irrelevant potential energy of the other particles.

Conservation of Energy for One Particle: If only the i th particle of the system can move, then the total energy of the system can be written

$$E_{TOT} = K_i + U_i = \text{constant}$$

where U_i is the potential energy of the i th particle and the energy is constant only if the system is isolated.

This can be re-written in terms of the change in energy. For an isolated system the sum of the change in kinetic energy, K_i , and the change in potential energy, U_i , is zero

$$\Delta K_i + \Delta U_i = 0$$

If the particle only moves in the x -direction, then the potential energy has the form $U_i(x)$. We can predict many of the qualitative features of particle's motion just from the shape of potential energy function. Consider a particle released in the potential energy function below, with total potential energy E_{TOT} .

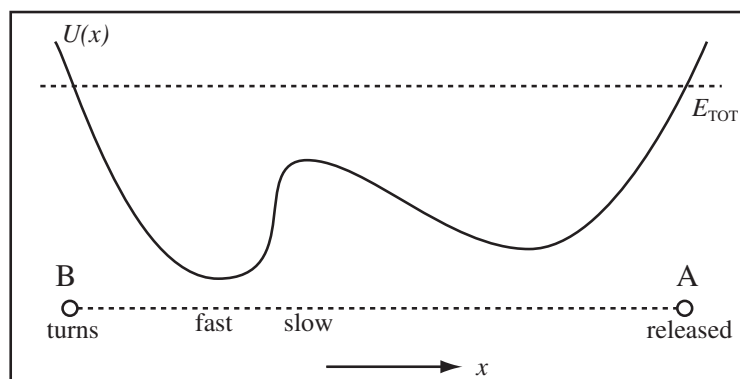

If a particle is released at point A with zero kinetic energy, the particle will travel to the left converting potential energy into kinetic energy. Eventually, it reaches point B where the total energy of the particle is all potential and the particle turns. Since there are no losses, the particle oscillates between A and B forever. If we are given or can find the potential energy $U_i(x)$ and the point where the particle is released, x_0 , then the kinetic energy at any point can be predicted. Since the particle is released at rest, the kinetic energy at x_0 is zero, $K_i(x_0) = 0$. The change in kinetic energy plus the change in potential energy is zero

$$\Delta K_i + \Delta U_i = 0 = (K_i(x) - K_i(x_0)) + (U_i(x) - U_i(x_0)) = 0$$

or in terms of the total energy $E_{TOT} = K_i(x_0) + U_i(x_0) = U_i(x_0)$

$$K_i(x) + U_i(x) = E_{TOT} = U_i(x_0)$$

Example 16.1 Dr. Stewart Falls Through the Earth

Problem: If a hole in the Earth opened up under my feet and I fell through the hole to the center of the Earth, my potential energy would be

$$U = \frac{mgr^2}{2R_e}$$

where $m = 100\text{kg}$ is my mass, $g = 9.81\frac{\text{m}}{\text{s}^2}$ is the acceleration of gravity, r is the distance from the center of the Earth, and $R_e = 6.4 \times 10^6\text{m}$ is the radius of the Earth. Calculate my velocity as I pass through the center of the earth.

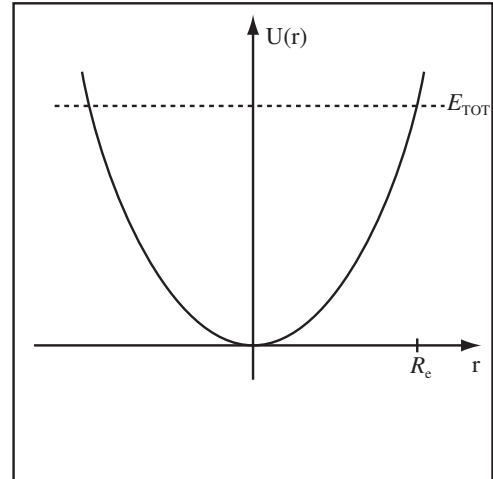

Solution

Since the hole opens up under my feet, my initial kinetic energy is zero, $K(R_e) = 0$, when I am a distance R_e from the center of the earth. Conservation of energy tells us

$$\Delta K + \Delta U = 0 = (K(0) - K(R_e)) + (U(0) - U(R_e)) = \left(0 - \frac{1}{2}mv_c^2\right) + \left(0 - \frac{mgR_e^2}{2R_e}\right)$$

where v_c is my velocity at the center of the Earth. Solve for v_c ,

$$v_c = \sqrt{gR_e} = \sqrt{\left(9.81\frac{\text{m}}{\text{s}^2}\right)(6.4 \times 10^6\text{m})} = 7,800\frac{\text{m}}{\text{s}}$$

Naturally, I fall completely through the Earth and only turn around as I reach the surface of the Earth on the other side of the planet.

My wife felt you would be alarmed by the above expression after your experience with gravity in UPI. It is true that g is only valid at the surface of the earth, but I can remember g . So to save looking up the gravitational constant G and the mass of the earth M , I used $GM = rR_e^2$. I also chose the zero of potential energy at the center of the Earth rather than at the surface of the Earth.

16.4 Potential Energy and Force

Now, hold on just a second. We know forces make things move. When we release the mass, it moves to lower potential energy, so there must be a force toward lower potential energy. There must be a fundamental relation between force and potential energy. The definition of potential energy in one dimension is

$$U(x) = \int_{x_0}^x F_x dx$$

where x_0 is the point where the potential energy is zero and F_x is the force an external agent must exert to move the particle with zero kinetic energy from x_0 to x . By the fundamental theorem of calculus, this implies

$$F_x = \frac{dU}{dx}$$

is the force the external agent must apply. The force F that the other particles exert on the particle must be equal and opposite the force the external agent must exert.

Force is the Derivative of Potential Energy: The force, F , on the particle x from the other particles of a system is

$$F = -\frac{dU}{dx}$$

where $U(x)$ is the potential energy of the particle.

Example 16.2 Force on Dr. Stewart Falling Through the Earth

Problem: The potential energy of Dr. Stewart as he falls through the Earth is

$$U = \frac{mgr^2}{2R_e}$$

where m is his mass, g is the acceleration of gravity, r is the distance from the center of the Earth, and $R_e = 6.4 \times 10^6 \text{m}$ is the radius of the Earth.

Calculate the force on Dr. Stewart at the Earth's surface and at the center of the Earth.

Solution

The force is the negative derivative of the potential energy

$$F(r) = -\frac{dU}{dr} = -\frac{d}{dr} \frac{mgr^2}{2R_e} = -\frac{mgr}{R_e}$$

where positive forces are directed upward. At the surface of the earth, $F(R_e) = -mg$, which is what we expected. At the center of the earth, $F(0) = 0$. So there is no force on me as I pass through the center of the earth at $7800 \frac{\text{m}}{\text{s}}$.

16.5 Two Dimensional Potential Energy Plots

Our field maps are two dimensional plots of charged systems. In the chapters to come, we will learn to add lines of constant potential energy to the field maps to represent the energy of the system. Many of you are already familiar with two dimensional representations of gravitational potential energy. The plot below is a topological map of area around Steamboat Springs, Colorado. The lines on the map are lines (contours) of constant elevation. Since gravitational potential energy mgh is proportional to height, this map is also a map of the gravitational potential energy. The lines are labelled with the elevation above sea level in feet. The same reasoning and conclusions you would draw from the map below carry over to the electrostatic equipotential maps we draw later.

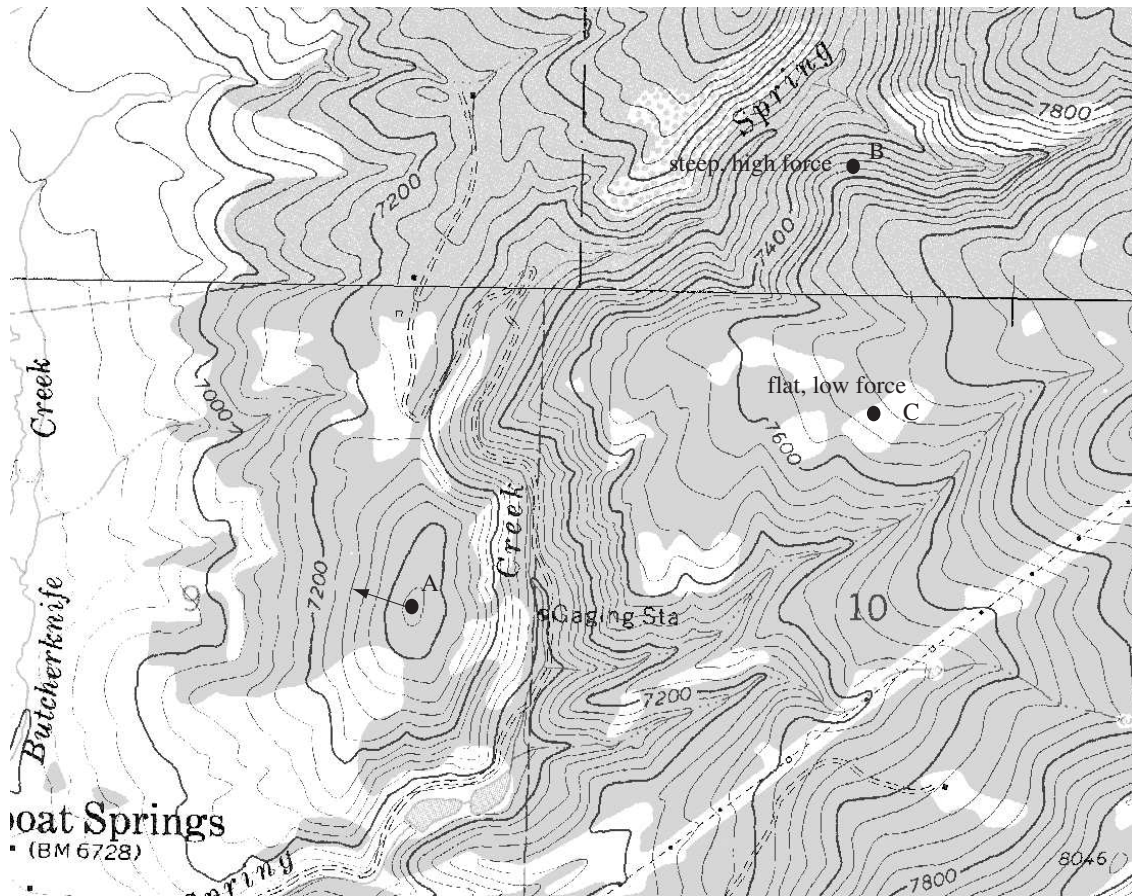

Point *A* is a local maximum in the potential energy, the top of a mountain. If a mass, like a skier, was placed at point *A* and released, they would feel a force toward lower potential energy and slide downhill. When the lines of equal potential energy are close together, the vertical elevation is changing in a short distance and the terrain is steeper. A skier placed at *B* would feel a large force down the mountain. Where the lines are farther apart, like at *C*, the country is flatter and the force down the mountain less. Remember, a skier is accelerated by the component of gravity along the ground.

Chapter 17

Electric Potential

17.1 Introduction to Electric Potential

As we considered energy in Course Guide 16, we investigated the total energy of a system of particles, E_{TOT} , the potential energy, U_i , of one of the particles of the system due to the internal forces of other particles in the system, and the work done by an external agent to move the particles around. In this chapter we get specific about the forces; we will investigate work and potential energy for a system of charged particles. We will investigate the total energy of a system of charged particles next chapter.

17.1.1 Potential and Potential Difference

Charged particles exert forces on one another. So if we take as our system a bunch of charged particles q_1, q_2, \dots, q_n , each charged particle, q_i , exerts a force $\vec{F}_{ij} = q_j \vec{E}_{ij}$ on every other particle q_j , where \vec{E}_{ij} is the electric field due to the i th particle at the location of j . An external agent (something outside of the system that exerts a force on the particles in the system) must do work to move charge q_i around in the field of the other particles. To move charge q_i from point \vec{r}_A to point \vec{r}_B along a path, an external agent must do work W_{AB}^i , defined as

$$W_{AB}^i = \int_{A \rightarrow B} \vec{F}_{ext}^i \cdot d\vec{\ell} = \sum \text{Component of Force along Path} \cdot \text{Length of Path}$$

where \vec{F}_{ext}^i is the force the external agent exerts and $d\vec{\ell}$ points along the path. The integral is taken along the path the particle moves.

If the external agent does not change the kinetic energy of the i th particle as it is moved along the path, then the work done is the change in potential energy ΔU_{AB}^i between the points \vec{r}_A and \vec{r}_B ,

$$W_{AB}^i = \Delta U_{AB}^i \quad \text{if } \Delta K^i = 0.$$

Only changes in energy actually matter in physics, so we get to pick the point where the energy is zero. Let the potential energy be zero at the point \vec{r}_0 which we will call the *reference point*. For systems of charged particles, the reference point will usually be a point far from the system of charge, "a point at infinity". With a choice of reference point, we can define the potential energy, $U^i(\vec{r}_A)$ of the i th particle at the point \vec{r}_A as the potential difference between the point \vec{r}_0 and the point \vec{r}_A ,

$$U^i(\vec{r}_A) = \Delta U_{0A}^i = W_{0A}^i$$

where the work must be done without changing the kinetic energy. So if we could get the work somehow, we could get the electric potential energy, the part of the potential energy due to the internal electric force.

Imagine the external agent moves the particle i at constant velocity so that the change in kinetic energy is zero. To do this, the external agent must exert a force \vec{F}_{ext}^i which exactly balances the total force exerted by the other charges of the system on charge i ,

$$\vec{F}_{ext}^i = - \sum_{j \neq i} \vec{F}_{ji} = -q_i \sum_{j \neq i} \vec{E}_{ji} = -q_i \vec{E}_i$$

where \vec{E}_i is the total electric field from the other charges in the system at the location of charge i . Substituting this into our definition of work gives

$$W_{AB}^i = \Delta U_{AB}^i = -q_i \int_{A \rightarrow B} \vec{E}_i \cdot d\vec{\ell}$$

Rather than working with electric force, we found working with electric force per unit charge, electric field, more powerful. While working with energy, we will find working with the difference in electric potential energy per unit charge more useful.

Definition Electric Potential Difference: The electric potential difference ΔV_{AB} between the point A and the point B along a path $\vec{\ell}$ in an electric field \vec{E} is defined to be

$$\Delta V_{AB} = - \int_{A \rightarrow B} \vec{E}_i \cdot d\vec{\ell}$$

where \vec{E}_i is the total electric field from the particles $j \neq i$, that is the other particles in the system. We will shorten the name of the electric potential difference to simply *potential difference* for this class.

Definition of Electric Potential: The electric potential $V(\vec{r}_A)$ at the point \vec{r}_A is the potential difference between a reference point, \vec{r}_0 , defined to have zero potential energy and the point \vec{r}_A ,

$$V(\vec{r}_A) = \Delta V_{0A}$$

We will shorten electric potential to potential for this class.

Units of Electric Potential and Electric Potential Difference: The SI unit for electric potential V and electric potential difference ΔV is the volt V. *The symbol representing potential and the symbol representing its units are very similar. Be sure to look at the context of the symbols to determine which meaning should be given.* Equivalent units for electric potential are:

$$1\text{V} = 1 \frac{\text{J}}{\text{C}} = 1 \frac{\text{N} \cdot \text{m}}{\text{C}}$$

New Units for Electric Field: When working with electric field it is often more convenient to use the units V/m instead of N/C for the electric field. They are equivalent.

$$1 \frac{\text{V}}{\text{m}} = 1 \frac{\text{N}}{\text{C}}$$

Electric Potential is Work per Unit Charge: This electric potential difference between a point A and a point B, ΔV_{AB} , is the work, W_{AB} , per unit charge an external agent must do to move a charge q from A to B along the path

$$\Delta V_{AB} = \frac{W_{AB}}{q}$$

Difference in Electric Potential Energy: The difference in electric potential energy of the charge q between the point \vec{r}_A and the point \vec{r}_B is the charge multiplied by the potential difference

$$\Delta U_{AB} = q\Delta V_{AB}$$

Computing Potential Difference from Potential: The potential difference between two points \vec{r}_A and \vec{r}_B can be computed from the electric potential

$$\Delta V_{AB} = V(\vec{r}_B) - V(\vec{r}_A) = V_B - V_A$$

The above rather lengthy set of definitions means we can calculate the change in potential energy, ΔU , of a charge q as it moves from point A to point B using

$$\Delta U = q(V(\vec{r}_B) - V(\vec{r}_A))$$

and from there conserve energy and get the change in kinetic energy and then the change in velocity. The electric potential is the integral of the electric field. The electric field can change discontinuously, for example inside and outside of a charged shell. An integral can not change discontinuously, therefore:

Continuity of Electric Potential: The electric potential is a continuous function, even at boundaries of regions where there is surface charge. A discontinuous potential would result in an infinite electric field.

Electric field may be added by the law of linear superposition, therefore electric potentials and electric potential differences may be added as long as a consistent reference point is chosen.

Additivity of Electric Potential: The total electric potential may be found by adding the potential produced by individual charges as long as a consistent reference point is used.

Example 17.1 Work Done by a Car Battery

Problem: The potential difference across the terminals of a car battery is about 12V. How much energy is added to an electron ($q_e = -1.602 \times 10^{-19}\text{C}$) as it moves from the positive to the negative terminal?

Solution

The work done by the battery $W = q_e \Delta V = (-1.602 \times 10^{-19}\text{C})(-12\text{V}) = 1.9 \times 10^{-18}\text{J}$ is equal to the energy added to the electron. From this number you may deduce that many electrons participate in electric current.

Example 17.2 Electron Accelerated Through Large Potential

Problem: The charge of the electron is $-1.6 \times 10^{-19}\text{C}$ and the mass is $9.11 \times 10^{-31}\text{kg}$. An electron initially at rest is accelerated through 30,000V. How fast is it going (neglecting relativity)?

Select One of the Following:

- (a) $3 \times 10^8 \frac{\text{m}}{\text{s}}$ (b) $1.05 \times 10^{16} \frac{\text{m}}{\text{s}}$ (c-Answer) $1 \times 10^8 \frac{\text{m}}{\text{s}}$ (d) $9.8 \times 10^{-8} \frac{\text{m}}{\text{s}}$

Solution

(c) $1 \times 10^8 \frac{\text{m}}{\text{s}}$: As the electron accelerates, its potential energy due to the electric field will be converted to kinetic energy, and so by Conservation of Energy

$$|\Delta U| = |\Delta K| = K_f$$

The difference in potential energy is related to the difference in potential through $\Delta U = q\Delta V$ so

$$|q\Delta V| = K_f = \frac{1}{2}mv_f^2$$

$$v_f = \sqrt{\frac{2q\Delta V}{m}} = 1.0 \times 10^8 \frac{\text{m}}{\text{s}}$$

17.1.2 Electric Potentials of a Single Variable

The definitions of the previous section apply for any electric field, no matter how complicated. Many systems have electric fields that have a simple directional dependence, like $\vec{E} = E(x)\hat{x}$ or $\vec{E} = E(r)\hat{r}$. All of the highly symmetric fields we have worked with fall into this category. Let's consider a field with the form $\vec{E} = E(r)\hat{r}$. The potential difference between the point $\vec{r}_A = r_A\hat{r}$ and the point $\vec{r}_B = r_B\hat{r}$ is

$$\Delta V_{AB} = - \int_{A \rightarrow B} \vec{E} \cdot d\vec{\ell} = - \int_{r_A}^{r_B} E(r) dr$$

if we choose to integrate outward from A to B along a radial path such that $d\vec{\ell} = \hat{r} dr$. If we choose A as the reference point and let \vec{r}_A become \vec{r}_0 and \vec{r}_B become \vec{r} the potential becomes

$$V(r) = - \int_{r_0}^r E(r) dr.$$

or using the indefinite integral:

Electric Potential for a Field that Points Along a Coordinate Direction: If the electric field has the form $E(x)\hat{x}$, $E(y)\hat{y}$, $E(z)\hat{z}$, or $E(r)\hat{r}$ then the electric potential for this field is given by the negative derivative of the field. If, for example, $\vec{E} = E(x)\hat{x}$, then

$$V(x) = - \int E(x) dx + C$$

where C is the constant of integration and is chosen so that $V(r_0) = 0$.

The fundamental theorem of calculus lets us undo the integral with a derivative, which allows the calculation of field from potential.

Calculation of Electric Field from Potential for Potentials with One Variable: If the electric potential depends on only one variable, then the electric field is the negative integral of the potential with respect to that variable. For example, if the potential is $V(x)$ then the electric field is

$$\vec{E} = - \frac{dV(x)}{dx} \hat{x}$$

where similar relations apply for $V(y)$, $V(z)$, and $V(r)$.

We will explore the properties of electric potential qualitatively in the next section, then work a bunch of examples for the rest of the chapter.

17.1.3 Independence of Path

The potential has an additional interesting property, the potential difference between two points does not depend on the path you take between two points. This allows us to take a problem where we are asked to compute the potential along a path where integration is difficult or impossible and select a different path between the two points which makes the calculation possible.

Independence of Path: Neither the work to move an electric charge nor the potential difference between any two points in an electric field depends on the path taken through the field. This means we can use the most convenient path to compute work and potential difference.

An alternate and equivalent statement of independence of path is that the total work to move a charge around a closed path in a static electric field is zero.

Work Around any Closed Path is Zero: If a charge is moved around a closed path in an electric field so that it returns to its starting point, the total work done on the charge is zero.

Independence of path sort of looks like an insignificant side feature, but it is actually a new fundamental law with the same importance as Coulomb's law. We will study this law when we get to magnetism, where it will be called Faraday's law. So independence of path is really an application of Faraday's law, where there are no changing magnetic fields. With that, I'll leave Faraday's law for magnetism. Independence of path places some strong constraints on what kind of static electric field maps we can draw.

Electric Field Lines Cannot

Be Closed Curves: The electric field map at the right cannot be the field map solely of a static electric field. If a charge q was dragged around the closed field line, work would be done at all points along the path, and net work would be done in a full circuit around the path, which violates independence of path. So there are no whirlpools in electric field maps. This is unfortunate because if such a field existed, we would have built a perpetual motion machine. Such electric fields are possible if a changing magnetic field is present.

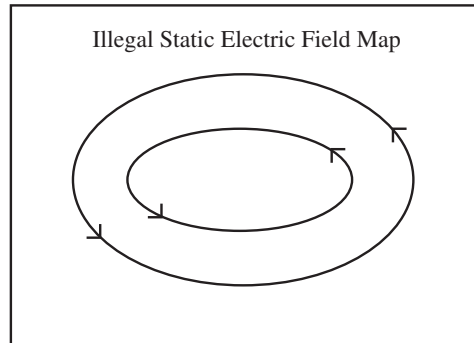

17.1.4 Batteries

A battery is a device which maintains a fixed potential difference between its two terminals. The only way to maintain or create a potential difference is to move charge. A battery is actually a chemical engine for pumping charge. The engine runs by using a chemical reaction to supply the energy to move the charge. Since the internal chemical reaction of the battery supplies energy to the system, the battery's internal energy must be included in any energy conservation equation.

Batteries as a Source of Potential Difference: A battery with voltage V_{batt} establishes a potential difference of $\Delta V_{-+} = V_{batt} = V_+ - V_-$ between the two terminals of the battery.

Circuit Symbol for Battery: A battery is represented in an electric circuit by the symbol to the right. The potential difference across the battery is measured from the negative to the positive end, $\Delta V_{bat} = V_B - V_A$

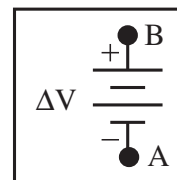

Since we have finally brought up the idea of an electric circuit, it is a good time for introducing our basic instrument for measuring potential difference, the voltmeter (the lab multimeter set in the DCV region).

17.2 Qualitative Features of Electric Potential

17.2.1 Qualitative Features of Electric Potential

If given an electric potential function or the electric potential difference between two points, the direction of the electric field can be found. The relative size of the field can be found if we know ΔV for several points.

An electric field is drawn to the right along with a path along which an external agent moves a positive charge. If a positive charge, q , is moved from A to B the electric force, \vec{F} , points opposite the direction of motion. An external agent would have to exert a force opposite to this force to get the charge to move from A to B . Since the external agent exerts a force in the direction the particle moves the work done by the external agent is positive. Therefore the potential energy increases as a positive charge moves from A to B and $V_B > V_A$.

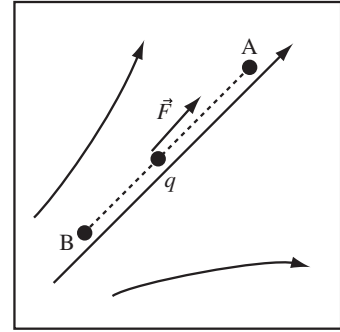

Potential Increases Opposite to the Direction of the Electric Field: The electric potential increases along a path that moves opposite to the direction of the electric field.

We can turn this around and use it figure out the direction of the field from the potential. If $\Delta V_{AB} > 0$ then you have to do work to move a positive charge from point A to B , therefore the electric field must on average point from B to A so that the electric force on the charge resists the motion.

Reasoning from Potential Difference to Electric Field: The electric field points to lower potential.

Since the electric field for a simple system is given by $E = -\frac{dV}{dx}$, the faster the potential changes with position, the stronger the field.

Reasoning About the Size of the Field Based on the Potential: The stronger the electric field, the greater the rate the electric potential changes with distance. Therefore, places where the electric potential changes quickly are places where the electric field is stronger.

There is no Potential Difference Across a Conductor: Since the electric field in a conductor is zero, there is no potential difference between different points in a conductor (if all charge is stationary).

Example 17.3 Reasoning from Potential to Field

Problem: Consider relative potentials on the x axis of 10V at $x = 2\text{m}$ and 12V at $x = 2.1\text{m}$. The electric field is parallel to the x -axis. Which direction does the average electric field point between these two positions on the x axis?

Solution

For the given potentials, the potential difference between $x = 2\text{m}$ and $x = 2.1\text{m}$ is $\Delta V_{2,2.1} = 2\text{V} > 0$, so the electric potential energy of a positive charge increases as it is moved from $x = 2\text{m}$ to $x = 2.1\text{m}$. Since the potential energy increases an external agent must do work ON a positive charge to move it from $x = 2\text{m}$ to $x = 2.1\text{m}$. For an external agent to have to push on a positive charge to move it in the $+\hat{x}$ direction, the electric field must point in the $-\hat{x}$ direction.

Example 17.4 Where is Field Strongest?

Problem: For some configuration of charge, the electric potential is given by the function, $V(x) = \gamma x^2$, where $\gamma > 0$ is a constant.

- (a) What direction does the electric field point for points $x > 0$?
- (b) Is the average electric field larger at $(0\text{cm}, 1\text{cm})$ or $(1\text{cm}, 2\text{cm})$?

Solution to Part(a)

The electric field points from high potential to low potential, since you have to do work on a positive charge to move it to higher potential. Therefore, the electric field points in the negative x direction.

Solution to Part(b)

The electric field is strongest where the potential changes the fastest; therefore, the electric field is strongest at (1cm, 2cm).

17.2.2 Drawing Equipotential Surfaces

Our field maps are drawings of the electric force per unit charge. In this section, we learn how to add a drawing of the electric energy per unit charge to the maps. An equipotential is a line (or surface in 3-D), where all points on the line are at the same potential or equivalently where there is zero potential difference between two points on the line. Since we draw in two dimensions our equipotentials are lines, but charges actually exist in three dimensions so equipotentials are really surfaces. First, some properties of lines of equipotential, then an example showing how to add them to a field map.

Equipotentials Perpendicular to Field Lines: Equipotentials cross field lines at right angles. Since the potential difference between points is an integral of $\vec{E} \cdot d\vec{l}$, it takes no work to move \perp to the electric field.

Spacing Proportional to Field: The spacing of the equipotential surfaces should represent approximately equal jumps in potential. So the spacing between surfaces should increase as the separation of field lines increases (and therefore the electric field decreases).

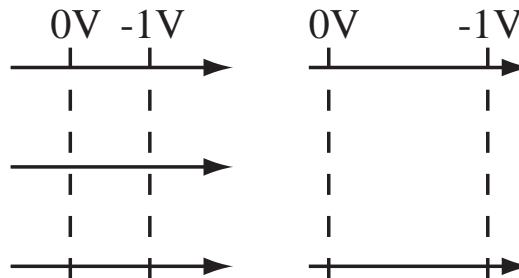

Equipotentials Do Not Cross: If two equipotentials cross, then they must have the same potential. If they have different electric potentials then the electric potential has two values at the same point. Not allowed.

Conductors are equipotential surfaces: Since \vec{E} is perpendicular to the surface of a conductor, the surface is an equipotential surface. Since $\vec{E} = 0$ inside a conductor, all points in that conductor are at the same potential, because it takes no work to move a charge in zero electric field. Make sure none of the equipotentials you add to a field map cross a conductor.

From an electric field map with equipotentials, we can reason about the relative magnitude of the potential along different equipotentials and the relative work to move from point to point on a field map.

No Work to Move along Equipotential: Since an equipotential is, by definition, all at the same potential, it takes no work to move along an equipotential.

Electric Potential Increases Opposite to Direction of Field Lines: If two equipotentials are connected by an electric field line, the equipotential the field lines point to will have lower potential. Potential difference is work per unit charge, so if we would have to work to move a positive charge from point 2 to point 1, as above, then the potential is higher at point 1.

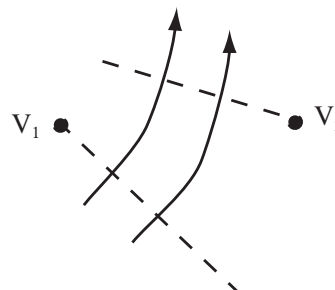

Example 17.5 Drawing Equipotential Surfaces

Problem: Two point charges $+Q$ are at $x = \pm 1\text{cm}$ along the x axis. Draw the field map and the equipotential surfaces.

Solution

(a) Select Points for Equipotentials: After drawing the field map, plan the spacing of the equipotentials. The spacing of the equipotentials should yield an approximately equal spacing in potential. To get this we choose, along some line, a set of points whose spacing increases with decreasing electric field, that is with decreasing density of electric field lines. For our sample problem, the points A, B, C, and D are chosen. The spacing between A and B sets the scale, the spacing between B and C is somewhat larger because the field lines are farther apart. The spacing between C and D is much larger because the field lines are very far apart.

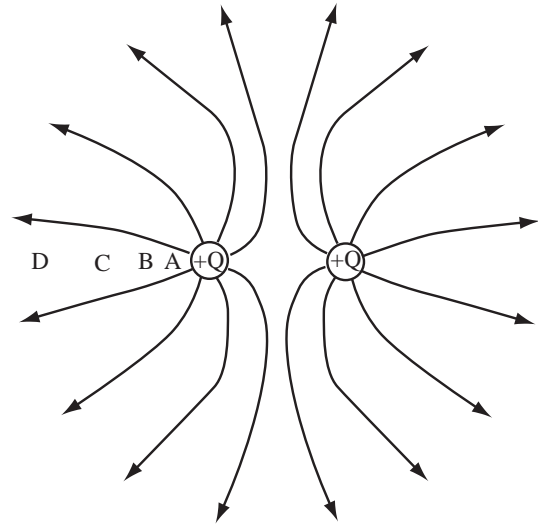

(b) Draw equipotentials: Starting and ending at each point you selected, draw a closed curve that intersects each field line at a right angle. Some of the curves may close outside the area of your figure.

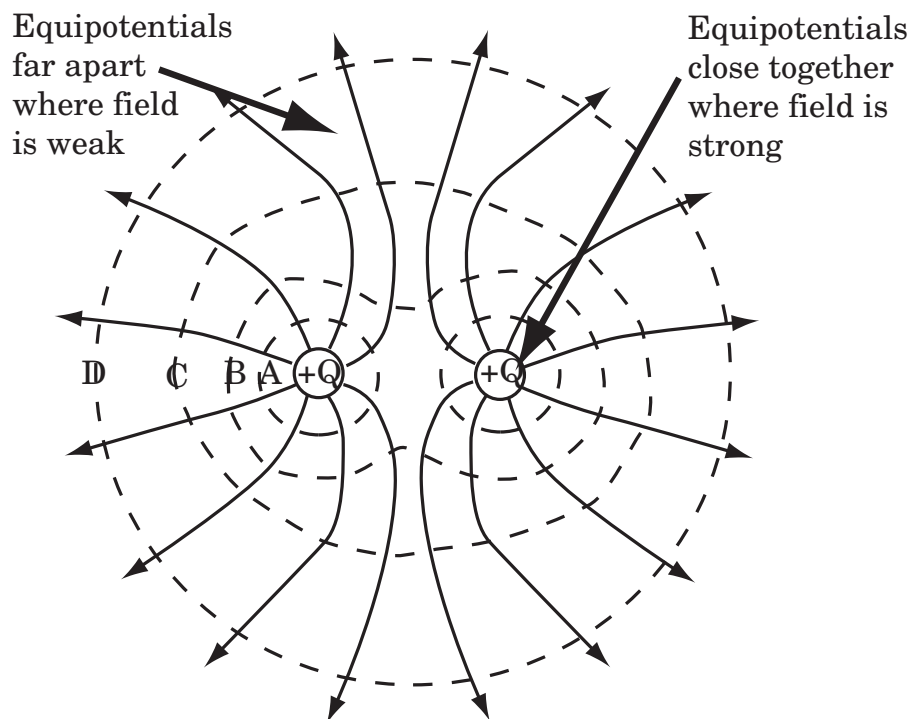

Example 17.6 Drawing Equipotentials

Problem: Draw the equipotentials through the points A , B , and C , in the drawing at the right.

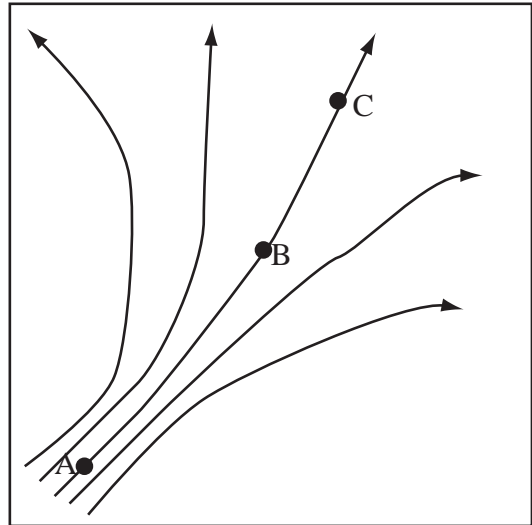

Solution

The equipotentials cross the field lines at right angles.

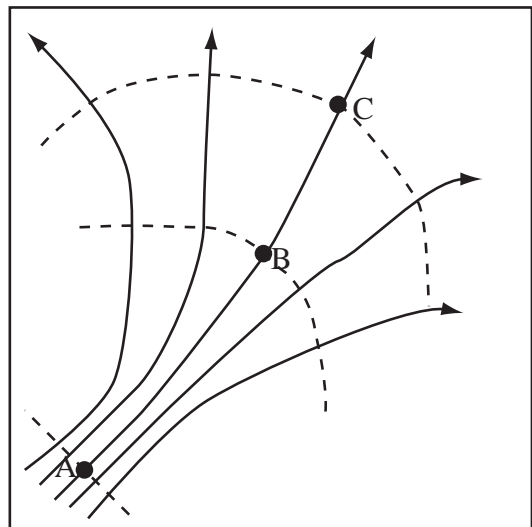
**Example 17.7 Equipotentials of a Dipole Field Map**

Problem: A $+1\mu\text{C}$ charge is at $(-1\text{cm}, 0, 0)$ and a $-1\mu\text{C}$ charge is at $(1\text{cm}, 0, 0)$. Draw the field map and equipotentials.

Solution

The field map is just that of a dipole. To draw the equipotentials, draw dashed lines that are perpendicular everywhere to the field lines.

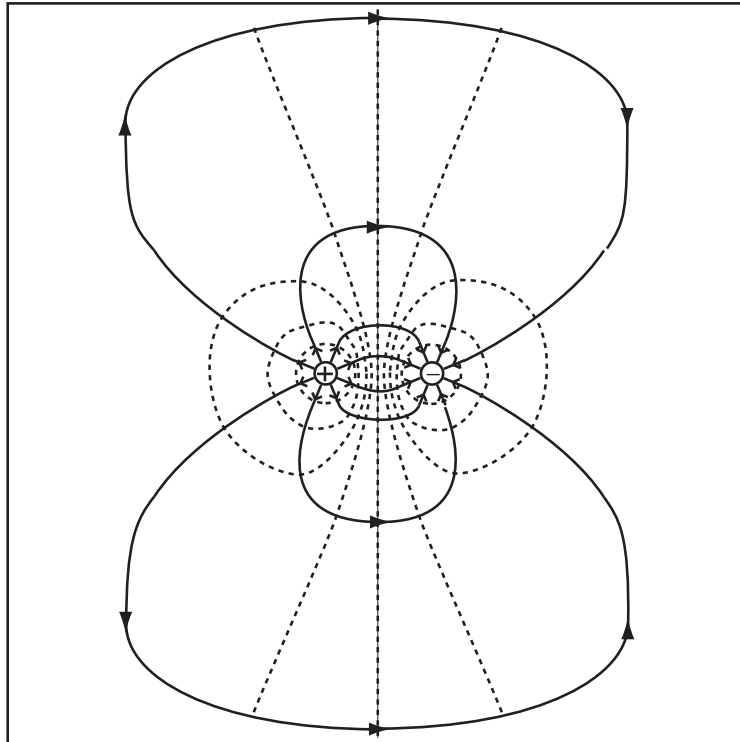
**Example 17.8 Equipotentials of Dipole and Square Conductor**

Problem: The figure below shows a $+Q$ and $-Q$ point charges with an uncharged conducting slab in between the charges.

- Draw the field map in the region between the conductors using 8 lines per $+Q$. You may draw the diagram on the figure below.
- Draw 8 equipotential surfaces.

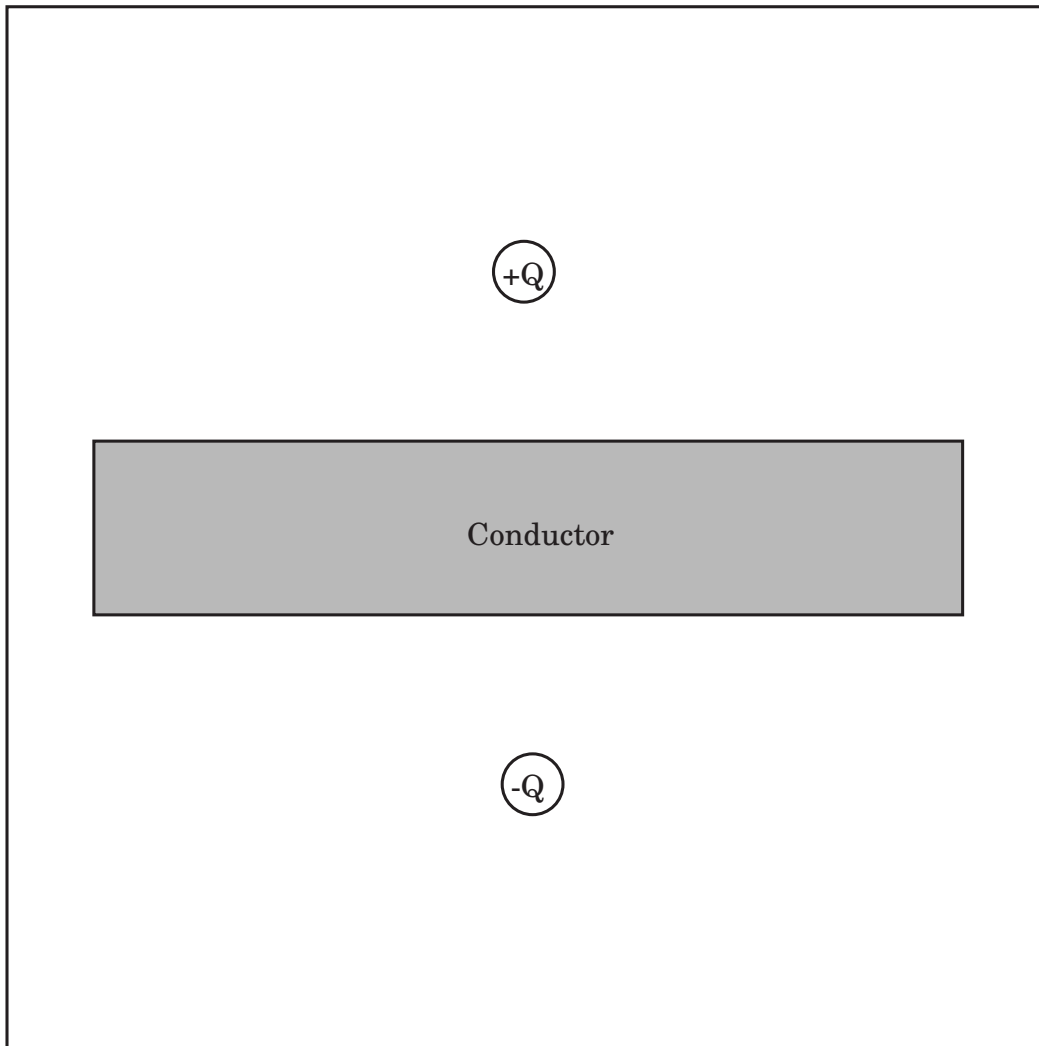

Solution to Part (a)

The field lines must be perpendicular to the conductor surface.

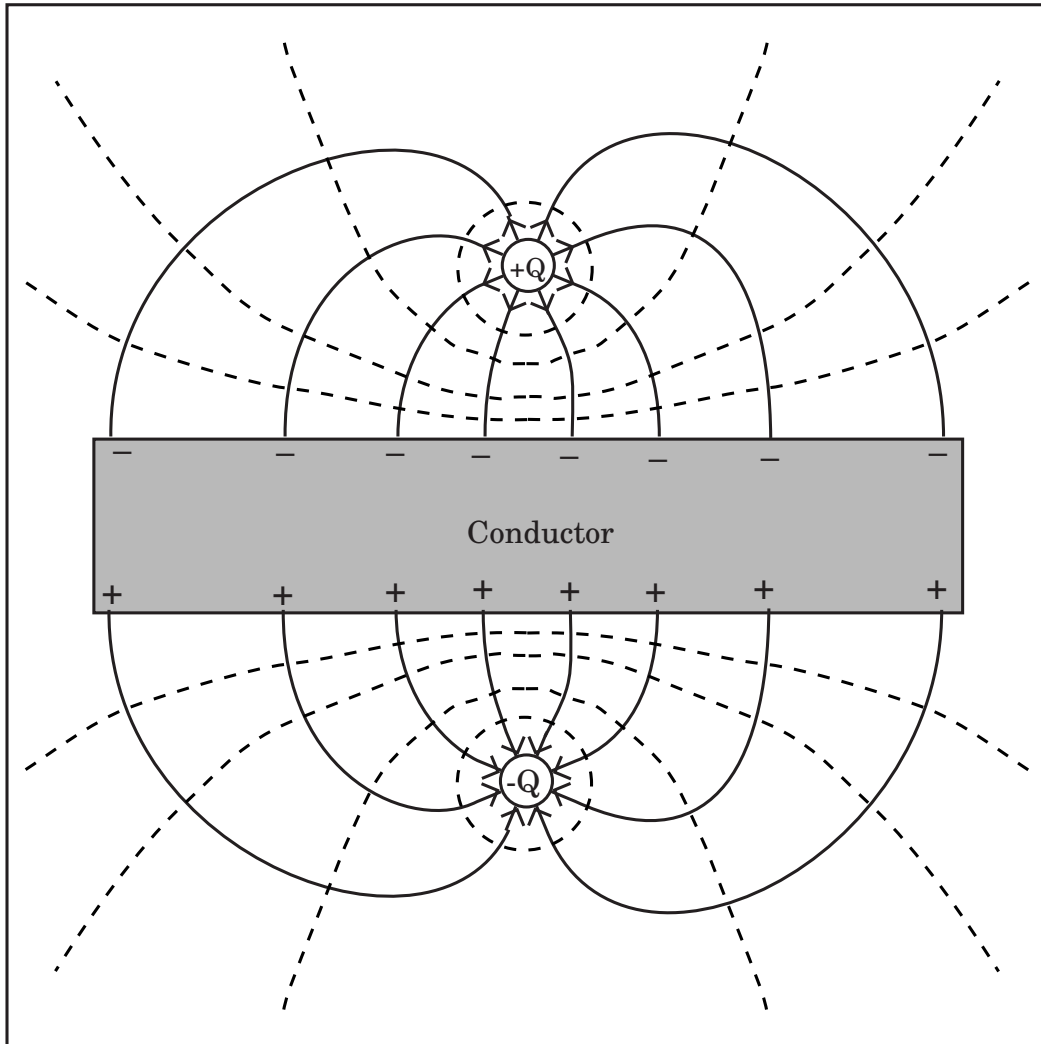

Solution to Part (b)

The equipotentials should be perpendicular to the field lines.

Example 17.9 Reasoning About Potential Difference

Problem: Which is larger, the work needed to move a $-1\mu\text{C}$ charge from point A to point B or from point A to point C along the paths drawn?

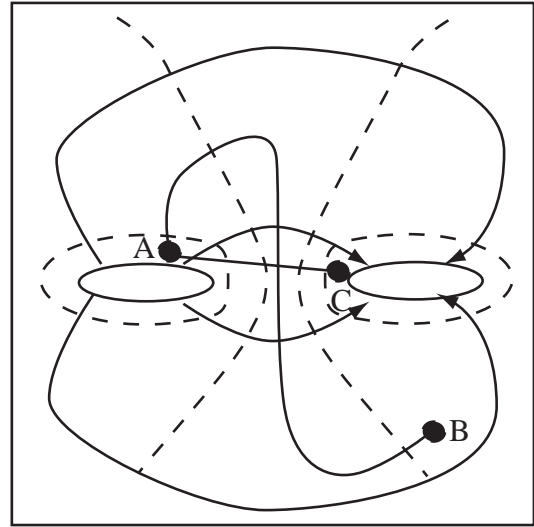

Solution

As we move along the field line shown with greater thickness in the figure at the right, the equipotentials 1, 2, 3, and 4 are crossed. A positive charge would be dragged along this line by the field; therefore, the potential of the equipotentials that the field line crosses can be ordered, $V_1 > V_2 > V_3 > V_4$. Going from A to B leaves a charge at a potential between V_3 and V_4 . Going from A to C leaves the charge with a potential less than V_4 . Therefore, the potential difference, $|\Delta V_{AB}| < |\Delta V_{AC}|$, but since both potential differences are negative, $\Delta V_{AB} > \Delta V_{AC}$. If the inequality is multiplied by a negative charge, q , the sign flips around again.

$$q\Delta V_{AB} < q\Delta V_{AC}$$

Therefore, the work to move from A to C is larger.

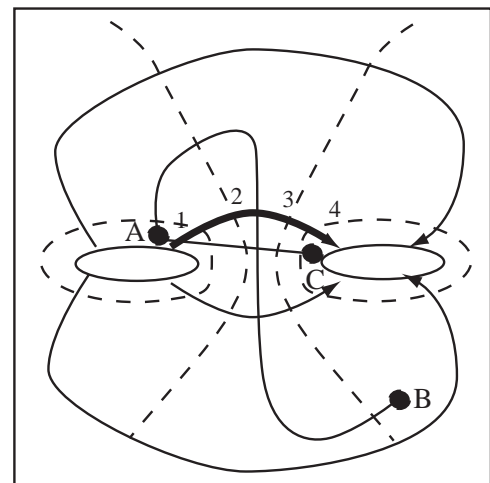

17.3 Computing Potential from Field

17.3.1 Computing Potential Difference Directly from Definition

The new fundamental skill we need to learn is to compute the potential difference given (or having solved for) the electric field. To do this, we have to do the integral defining the electric potential. The integral that we have to do is a path integral that goes through a vector field. We have a few tricks available that are very helpful in reducing this daunting task to one a bit more tractable.

Select and Draw Path of Integration: The key step to using the definition of electric potential is to choose a convenient path of integration and to be able to write the simple integral which results from choosing this path. This is the path you push the charge along to move it from point A to point B .

Break Up Path: The most convenient path is sometimes a path made up of segments where some segments are parallel to the field and some are perpendicular to the field. The potential difference along the segments of the path perpendicular to the field will be zero.

Compute the Magnitude: Use the definition of potential to compute the magnitude of the electric potential, and then reason about the sign. It is sometimes remarkably hard to get the sign correct out of this path integral. So by definition of electric potential,

$$|\Delta V_{ab}| = \left| - \int_{\text{path}(a \rightarrow b)} \vec{E} \cdot d\vec{\ell} \right|$$

The sign of the potential difference will be the sign of the work you would do to move a positive charge from a to b .

Reason About Work: The electric potential is work per unit charge, so if you would have to do work to move a positive charge from point A to point B, then the potential is higher at point B than point A, and $\Delta V_{ab} > 0$.

Example 17.10 Find the Electric Potential Difference from the Electric Field

Problem: A uniform spherical volume of charge has charge density ρ and outer radius r_{edge} . Compute the potential difference between the outer edge of the sphere at r_{edge} and the center, ΔV_{ec} .

Solution

Definitions

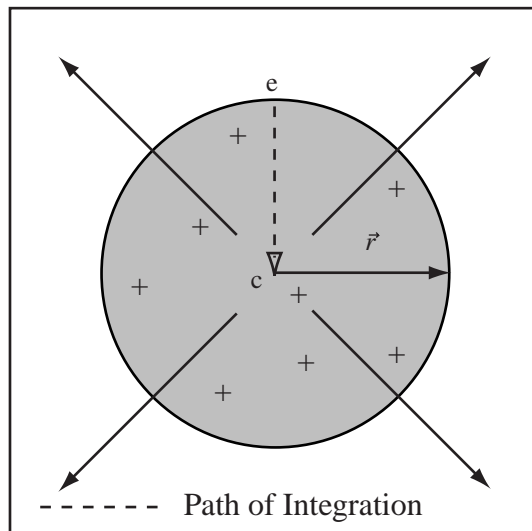

$\vec{E} \equiv$ Electric field
 $\Delta V_{ec} \equiv$ Potential Difference Between Outside and Center
 $r_{edge} \equiv$ Radius of Sphere

Strategy: Find the electric field. Use definition of electric potential, integrate it to get the magnitude of the potential difference, then use potential as work per unit charge to get the sign.

(a) Solve for the Electric Field: In the volume charge, a Gaussian surface of radius r encloses a total charge $Q_{enc} = \frac{4}{3}\pi r^3 \rho$. Using the form of Gauss' law for spherical symmetry, this yields

$$\vec{E} = \frac{Q_{enc}}{4\pi\epsilon_0 r^2} \hat{r} = \frac{\frac{4}{3}\pi r^3 \rho}{4\pi\epsilon_0 r^2} \hat{r}$$

$$\vec{E} = \frac{\rho r}{3\epsilon_0} \hat{r}$$

(b) Use Definition of Electric Potential: The electric potential difference between a point on the edge of the sphere and the center is

$$\Delta V_{ec} = - \int_{\text{path}} \vec{E} \cdot d\vec{\ell}$$

Separate the calculation into two parts: (1) the calculation of the magnitude $|\Delta V_{ec}|$ by doing the integral, (2) computing the sign by reasoning about the work.

(c) Select Path of Integration and Perform the Integral: Select a path of integration that makes the integral as easy to do as possible. Any path between the two points will yield the correct result. Draw the path

of integration on your diagram. Use the chosen path to convert the path integral to a simple integral. Choose a path of integration from the edge to the center along a radius. The vector $d\vec{\ell} = -\hat{r}dr$, so $\vec{E} \cdot d\vec{\ell} = -E(r)dr$,

$$|\Delta V_{ec}| = \left| \int_{r=r_{edge}}^{r=0} E(r) dr \right|$$

$$|\Delta V_{ec}| = \left| \int_{r=r_{edge}}^{r=0} \frac{\rho r}{3\epsilon_0} dr \right| = \frac{\rho r_{edge}^2}{6\epsilon_0}$$

(d) Reason About the Sign: Use the definition of potential difference as work done per unit charge to fix the sign. If $\rho > 0$, then the field points outward and we would do work on a positive charge to move it from a point on the edge to the center, so if $\rho > 0$ $\Delta V > 0$, so

$$\Delta V_{ec} = \frac{\rho r_{edge}^2}{6\epsilon_0}$$

The answer is also correct if $\rho < 0$, because the sign of ρ takes care of the sign of the potential.

Example 17.11 Potential Difference along y-axis

Problem: An electric field is given by $\vec{E}(y) = \gamma y^2 \hat{y}$, where $\gamma = 150 \frac{\text{N}}{\text{Cm}^2}$. What is the electric potential difference ΔV_{AB} between point A at $(0, 2\text{cm}, 0)$ and point B at $(0, 1\text{cm}, 0)$?

Solution

(a) Use Definition of Electric Potential: The electric potential difference between point A and point B is

$$\Delta V_{AB} = - \int_{A \rightarrow B} \vec{E} \cdot d\vec{\ell}$$

Separate the calculation into two parts: (1) the calculation of the magnitude $|\Delta V_{AB}|$ by doing the integral, (2) computing the sign by reasoning about the work.

(b) Select Path of Integration and Perform the Integral: Select a path of integration that makes the integral as easy to do as possible. Choose a straight path along the y -axis from point A to point B , therefore $d\vec{\ell} = -\hat{y}dy$. To simplify notation let $\vec{r}_A = (0, a, 0)$ where $a = 2\text{cm}$ and $\vec{r}_B = (0, b, 0)$ where $b = 1\text{cm}$. The path of integration is drawn below. Substitute $d\vec{\ell}$ and $\vec{E}(y)$ into the expression for potential and perform the integral.

$$\Delta V_{AB} = \left| - \int_a^b \vec{E}(y) \cdot (-\hat{y}dy) \right|$$

$$|\Delta V_{AB}| = \left| \int_a^b \gamma y^2 dy \right| = \left| \left(\gamma \frac{y^3}{3} \right) \Big|_a^b \right| = \left| \frac{\gamma}{3} \left(b^3 - a^3 \right) \right|$$

$$|\Delta V_{AB}| = \left| \frac{(150 \frac{\text{N}}{\text{Cm}^2})((0.01\text{m})^3 - (0.02\text{m})^3)}{3} \right| = 3.5 \times 10^{-4} \text{V}$$

(c) Reason About the Sign: Use the definition of potential difference as work done per unit charge to fix the sign. Since $\gamma > 0$, the electric field points in the $+\hat{y}$ direction, so we have to do work to move a positive test charge from $y = 2\text{cm}$ to $y = 1\text{cm}$, therefore $\Delta V_{AB} > 0$. Therefore,

$$\Delta V_{AB} = 3.5 \times 10^{-4} \text{V}.$$

The field and path of integration is drawn to the right. Note since the field is getting stronger in the y direction, more field lines start as y increases. This means the region contains net charge.

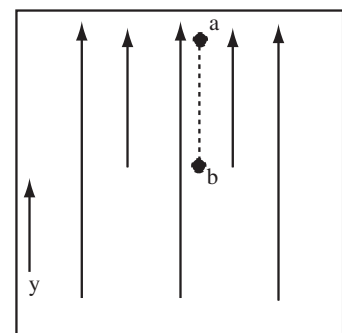

17.3.2 Calculating Potential Difference from Potential

The examples above both involve electric fields that point along coordinate directions, in the cases above \hat{y} and \hat{r} . For these cases, we can calculate the potential, V , up to a constant by simply integrating the field. The potential difference can then be calculated by $\Delta V_{AB} = V_B - V_A$.

Example 17.12 Electric Potential Difference from Potential for a Radial Field

Problem: A uniform spherical volume of charge has charge density ρ and outer radius r_{edge} . Compute the potential difference between the outer edge of the sphere at r_{edge} and the center, ΔV_{ec} .

Solution

Definitions

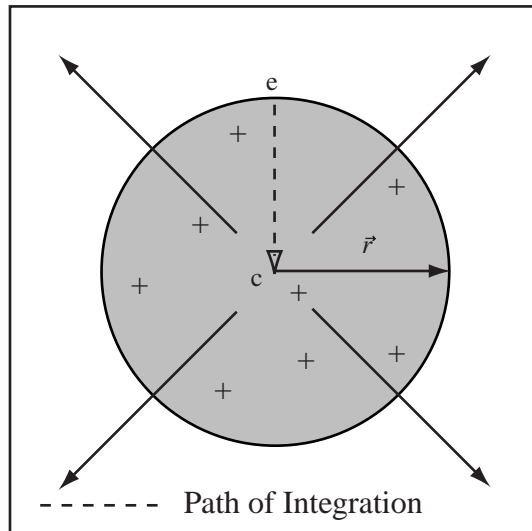

$\vec{E} \equiv$ Electric field
 $\Delta V_{ec} \equiv$ Potential Difference Between Outside and Center
 $r_{edge} \equiv$ Radius of Sphere

(a) Solve for the Electric Field: In the volume charge, a Gaussian surface of radius r encloses a total charge $Q_{enc} = \frac{4}{3}\pi r^3 \rho$. Using the form of Gauss' law for spherical symmetry, this yields

$$\vec{E} = \frac{Q_{enc}}{4\pi\epsilon_0 r^2} \hat{r} = \frac{\frac{4}{3}\pi r^3 \rho}{4\pi\epsilon_0 r^2} \hat{r}$$

$$\vec{E} = \frac{\rho r}{3\epsilon_0} \hat{r}$$

(b) Use Definition of Electric Potential: Since the electric field points only in the \hat{r} direction, the definition of electric potential difference allows the calculation of the electric potential through

$$V(r) = - \int E(r) dr$$

where the constant of integration can be used to make it so the potential is zero at the reference point.

(c) Perform the Integral: Substitute the value of $E(r)$ calculated from Gauss' law.

$$V(r) = - \int \frac{\rho r}{3\epsilon_0} dr = - \frac{\rho r^2}{6\epsilon_0} + C$$

where C is the constant of integration.

(d) Calculate the Potential Difference: The electric potential difference between the edge, r_{edge} , and the origin is

$$V_{ec} = V(0) - V(r_{edge}) = C - \left(- \frac{\rho r_{edge}^2}{6\epsilon_0} + C \right) = \frac{\rho r_{edge}^2}{6\epsilon_0}$$

where the sign will be correct if we did the calculus correct. Note, the constant of integration, which contained our arbitrary choice of the zero of potential cancelled when we calculated potential difference.

We didn't need to set the constant C to calculate the potential difference in a single region. The normal choice for the reference point in a spherical problem is $V(\infty) = 0$, but since the field is different for $r > r_{edge}$ the potential function calculated is incorrect if $r > r_{edge}$. We could however choose to report the potential with the center of the sphere as the reference point. In this case $V(0) = 0 \rightarrow C = 0$.

Example 17.13 Potential Difference along y-axis

Problem: An electric field is given by $\vec{E}(y) = \gamma y^2 \hat{y}$, where $\gamma = 150 \frac{\text{N}}{\text{Cm}^2}$. What is the electric potential difference ΔV_{AB} between point A at $(0, 2\text{cm}, 0)$ and point B at $(0, 1\text{cm}, 0)$?

Solution

(a) Use Definition of Electric Potential: Since the electric field points only along the coordinate axis, the definition of potential difference can be used to calculate the potential as

$$V(y) = - \int E(y) dy$$

where the constant of integral will be used to fix the zero of potential.

(b) Perform the Integral: Substitute the function given and perform the integral

$$V(y) = - \int \gamma y^2 dy = -\frac{\gamma}{3} y^3 + C$$

(c) Calculate Potential Difference: Once again let $\vec{r}_A = (0, a, 0)$ and $\vec{r}_B = (0, b, 0)$. The potential difference between point A and point B is

$$\Delta V_{AB} = V(b) - V(a) = \left(-\frac{\gamma}{3} b^3 + C \right) - \left(-\frac{\gamma}{3} a^3 + C \right) = \frac{\gamma}{3} (a^3 - b^3)$$

Substitute,

$$\Delta V_{AB} = \frac{150 \frac{\text{N}}{\text{Cm}^2}}{3} ((2\text{cm})^3 - (1\text{cm})^3) = 3.5 \times 10^{-4} \text{V}.$$

where the sign should be correct if we've integrated properly.

To complete the calculation of the potential above, we would have to set the constant C . For planar systems, we usually choose $V(0) = 0$. With this choice $C = 0$. You can check either of the above calculations by using $E(y) = -dV/dy$ for potentials of only one variable.

17.3.3 Electric Potential Difference in Uniform Field

An important and simple example of the calculation of the electric potential difference from the electric field comes from systems with uniform fields. We encountered these fields over and over in systems of parallel planes. Suppose the field is uniform in the x direction, $\vec{E} = E\hat{x}$. If $E > 0$, the field points in the positive x direction. Since the potential decreases in the direction of the electric field, the potential decreases as x increases. Using the definition of potential difference,

$$|\Delta V_{AB}| = \left| - \int E dx \right| = \left| E \int dx \right| = |E \Delta x|$$

where Δx is the distance moved in the x direction. Since potential decreases as x increases, $\Delta V = -E \Delta x$.

Potential Difference in Uniform Field: If the electric field is uniform in the x direction, $\vec{E} = E\hat{x}$, then the potential difference between a point x_a and the point x_b is

$$\Delta V_{ab} = -E(x_b - x_a)$$

or the potential difference between two points a distance d apart in the x direction is $|\Delta V| = Ed$.

Potential in a Uniform Field: If a field is uniform and directed in the x direction, $\vec{E} = E\hat{x}$, and the point $x = 0$ is selected as the zero of potential, then the electric potential is

$$V(x) = -Ex$$

Example 17.14 Charge on Pie Pans

Problem: The pie pans have a radius of about 10cm. Equal and opposite charges are placed on two pie pans that are parallel and 3mm apart. How much charge must be placed on the positive pan (an equal and opposite charge is placed on the negative pan) to generate a potential difference between the pans of 1200V?

Solution

The electric field between equal and opposite planes of charge is

$$\vec{E} = \frac{\sigma}{\epsilon_0} \hat{x}.$$

The potential difference for a uniform field is

$$|\Delta V| = |Ed| = \left| \frac{\sigma d}{\epsilon_0} \right|,$$

where σ is the charge density.

This means that the charge density required to set up a 1200 V potential difference is

$$\begin{aligned} \sigma &= \frac{\Delta V \epsilon_0}{d} = \frac{(1200\text{V})(8.85 \times 10^{-12} \frac{\text{C}^2}{\text{Nm}^2})}{0.003\text{m}} \\ &= 3.54 \times 10^{-6} \frac{\text{C}}{\text{m}^2}. \end{aligned}$$

The total charge is the density multiplied by the area of the plate,

$$\begin{aligned} Q &= \sigma A = \sigma \pi r^2 = (3.54 \times 10^{-6} \frac{\text{C}}{\text{m}^2}) \pi (0.1\text{m})^2 \\ &= 1.11 \times 10^{-7} \text{C}. \end{aligned}$$

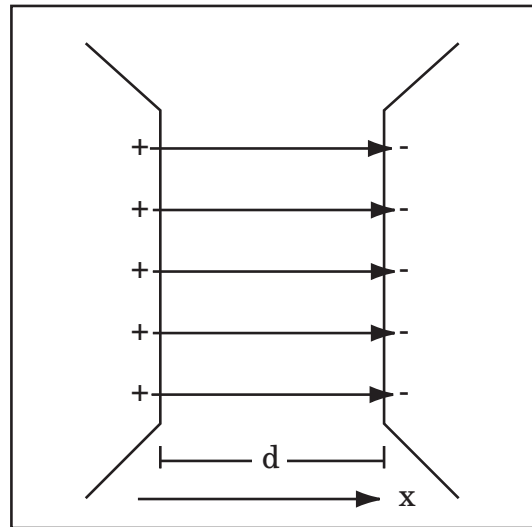

17.4 Calculating Potential Directly from Charge

17.4.1 Electric Potential of a Point Charge

We argued that the electric field, \vec{E} , of any system of charge could be found from Coulomb's law and the law of Linear Superposition by cutting the system into small chunks, q_i , calculating the field of each chunk, and adding

$$\vec{E}(\vec{r}_P) = \sum_i \frac{kq_i}{r_{iP}^2} \hat{r}_{iP}$$

We can substitute this electric field into the definition of potential difference to find the potential difference between point A and B for any system of point charges

$$\Delta V_{AB} = - \int_{A \rightarrow B} \vec{E}(\vec{r}_P) \cdot d\vec{\ell} = \sum_i \left(\frac{kq_i}{r_{iP}^2} \hat{r}_{iP} \cdot d\vec{\ell} \right)$$

but the thing in parenthesis is just the potential difference due to a point charge. So we can calculate any potential difference simply by summing the potential difference due to each point charge. This can be made even cleaner if we focus on potential instead. Since a point charge has a field that only depends on r , we can calculate the potential of the point charge simply by integrating

$$V(r) = - \int E(r) dr = - \int \frac{kq}{r^2} dr = \frac{kq}{r} + C$$

The reference point usually chosen from a point charge is $V(\infty) = 0$, so

Electric Potential of Point Charge: The electric potential, $V_1(\vec{r}_A)$, at point \vec{r}_A due to a point charge q_1 at point \vec{r}_1 is:

$$V_1(\vec{r}_A) = \frac{kq_1}{r_{1A}},$$

where r_{1A} is the distance from point \vec{r}_1 to the point A . The reference point for this potential is a point infinitely far from the charge.

The potential of a point charge depends only on the distance, r , from the charge.

Example 17.15 Reasoning about Moving a Charge in an Electric Field

Problem: A point charge with charge $Q = 5\mu\text{C}$ is located at the origin. How much work is required to move a $-1\mu\text{C}$ charge from $(10\text{cm}, 10\text{cm}, 0)$ to $(-10\text{cm}, 10\text{cm}, 0)$?

Solution

The potential of a point charge just depends on the distance from the charge. Since we begin and end at the same distance from the point charge, the potential difference between the beginning and ending points is zero. Therefore, the work to move any charge between the two points given is zero.

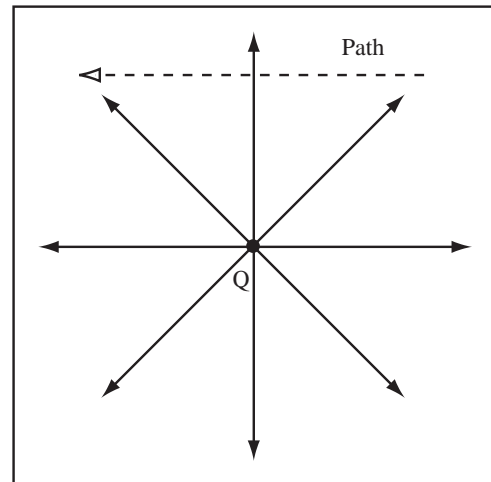

For one point charge, all we need to compute the potential is the distance between the charge and the point where we want to know the potential. No vectors, now isn't life getting better all the time? We can compute the potential of any system of charge simply by adding the potentials.

Electric Potential of a System of Point Charges: Because potential is additive, the electric potential of a system of point charges q_i is the sum of the potentials of the individual charges

$$V(\vec{r}_P) = \sum_i V_i(\vec{r}_P) = \sum_i \frac{kq_i}{r_{iP}}$$

where r_{iP} is the distance from the charge q_i to the point P .

Example 17.16 Electric Potential of a Point Charge

Problem: A $3\mu\text{C}$ charge is located at $x = 4\text{cm}$, $y = 2\text{cm}$, $z = 0\text{cm}$, Point 1. Compute the electric potential at point P at $x = -3\text{cm}$, $y = -3\text{cm}$, $z = 0\text{cm}$, if the potential at ∞ is zero.

Solution

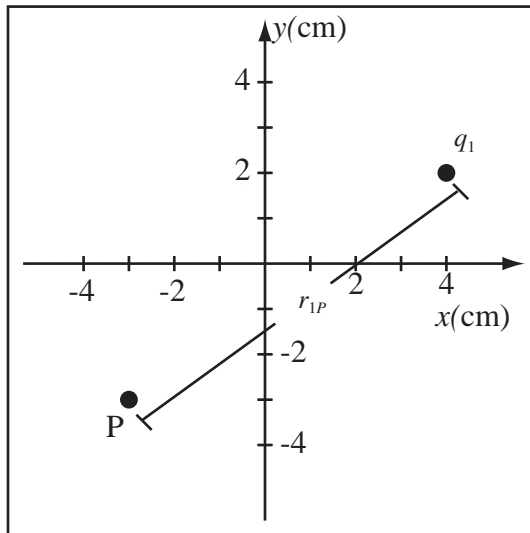

Definitions

- $q_1 = 3\mu\text{C} \equiv$ Charge producing the potential
 $\vec{r}_1 = (4\text{cm}, 2\text{cm}, 0\text{cm}) \equiv$ Location of q_1
 $P \equiv$ Location where potential is computed
 $\vec{r}_2 = (-3\text{cm}, -3\text{cm}, 0\text{cm}) \equiv$ point P
 $V_{1P} \equiv$ Potential at P due to q_1
 $V_0 \equiv$ Arbitrary constant in point charge equation
 $r_{1P} \equiv$ Distance from q_1 to P

(a) Use Electric Potential of Point Charge: The electric potential at P from the field of q_1 is

$$V_{1P} = \frac{kq_1}{r_{1P}}$$

(b) Compute distance between q_1 and P: Observing the diagram, the distance between q_1 and P is found by applying the Pythagorean Theorem,

$$r_{1P} = \sqrt{(-7\text{cm})^2 + (-5\text{cm})^2 + 0} = 8.6\text{cm}$$

(c) Substitute and Solve:

$$V_{1P} = \frac{(8.99 \times 10^9 \frac{\text{Nm}^2}{\text{C}^2})(3 \times 10^{-6}\text{C})}{0.086\text{m}}$$

$$V_{1P} = 3.14 \times 10^3 \frac{\text{Nm}}{\text{C}} = 3.14 \times 10^3\text{V}$$

The total potential function for a set of point charges is just the sum of the potential functions of the individual point charges.

Example 17.17 Compute Electric Potential of a Collection of Point Charges

Problem: Given $1\mu\text{C}$ charges at $\pm x = 4\text{cm}$ and $\pm x = 1\text{cm}$, compute the electric potential at the origin if the potential at \vec{r}_∞ is zero.

Solution

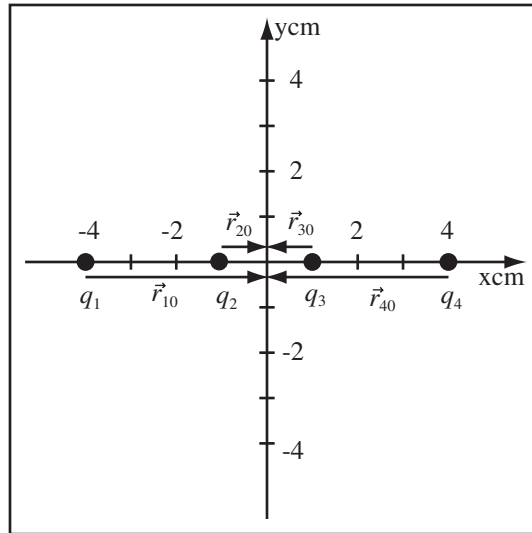

Definitions

$V_{i0} \equiv$ Potential at origin from q_i

$q_1 = q_2 = 1\mu\text{C} \equiv$ Point charges

$q_3 = q_4 = 1\mu \equiv$ Point charges

$\vec{r}_{10} = (4\text{cm}, 0, 0) \equiv$ Vector from 1 to 0

$\vec{r}_{20} = (1\text{cm}, 0, 0) \equiv$ Vector from 2 to 0

$\vec{r}_{30} = (-1\text{cm}, 0, 0) \equiv$ Vector from 3 to 0

$\vec{r}_{40} = (-4\text{cm}, 0, 0) \equiv$ Vector from 4 to 0

$V_0 \equiv$ Electric Potential at Origin

(a) Write Equation for Total Potential: By Principle of Additivity of Electric Potential, the total potential is the sum of the potentials from the individual charges. The total potential at the origin is

$$V_0 = \sum_i \frac{kq_i}{r_{i0}}$$

$$V_0 = V_{10} + V_{20} + V_{30} + V_{40}$$

where V_{i0} is the potential due to charge i at the origin.

(b) Use Symmetry: Since all q_i are the same value and the distance $r_{10} = r_{40}$ and $r_{20} = r_{30}$, $V_{10} = V_{40}$ and $V_{20} = V_{30}$ so,

$$V_0 = 2V_{10} + 2V_{20}.$$

(c) Compute V_{10} : The electric potential at the origin from charge q_1 , with our choice of V_∞ , is:

$$V_{10} = \frac{kq_1}{r_{10}}$$

$r_{10} = 4\text{cm}$ - From diagram

$$\begin{aligned} V_{10} &= \frac{(8.99 \times 10^9 \frac{\text{Nm}^2}{\text{C}^2})(1 \times 10^{-6}\text{C})}{0.04\text{m}} \\ &= 2.25 \times 10^5 \frac{\text{Nm}}{\text{C}} \end{aligned}$$

(d) Compute V_{20} :

$$V_{20} = \frac{kq_2}{r_{20}}$$

$r_{20} = 1\text{cm}$ - From diagram

$$\begin{aligned} V_{20} &= \frac{(8.99 \times 10^9 \frac{\text{Nm}^2}{\text{C}^2})(1 \times 10^{-6}\text{C})}{0.01\text{m}} \\ &= 8.99 \times 10^5 \frac{\text{Nm}}{\text{C}} \\ &= 8.99 \times 10^5 \text{V} \end{aligned}$$

(e) Compute Total Potential:

$$\begin{aligned} V_0 &= 2(2.25 \times 10^5 \text{V}) + 2(8.99 \times 10^5 \text{V}) \\ V_0 &= 2.25 \times 10^6 \text{V} \end{aligned}$$

17.4.2 Electric Potential of a Continuous System of Charge

I'm sure you can see where this is going. If we have a continuous system of charge, we can cut it up into tiny chunks and calculate its potential directly by integration. Let's revisit the system whose field you calculated by integration in lab.

Example 17.18 Calculate the Potential of a Finite Line Charge

Problem: A line charge of length $2L$ has charge density λ and lies along the x -axis with its center at the origin. Calculate the electric potential at a point a distance R along the y axis. The potential is zero at infinity.

Solution

(a) Cut the System into Pieces: The system is drawn to the right. Divide the system into small segments of length Δx and center x_i . The charge of each segment is $q_i = \lambda \Delta x$. The distance of each segment to the point P a distance R along the axis is

$$d_i = \sqrt{R^2 + x_i^2}$$

The electric potential at P is the sum of the potentials of each segment

$$V(R) = \sum_i \frac{kq_i}{d_i} = \sum_i \frac{k\lambda\Delta x}{\sqrt{R^2 + x_i^2}}$$

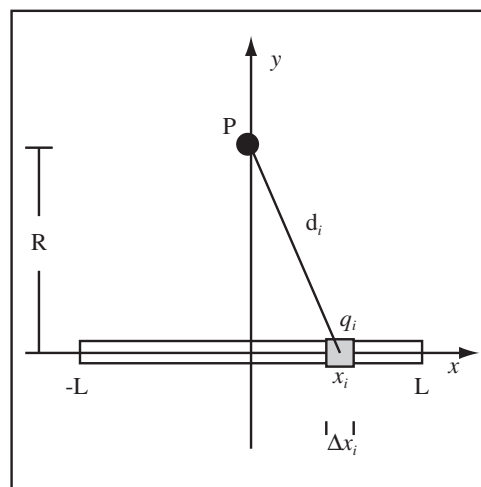

(b) Convert the Sum into an Integral: Let the segments become infinitely short to convert the sum into an integral, $\Delta x \rightarrow dx$, $x_i \rightarrow x$, and $\sum_i \int_{-L}^L$

$$V(R) = \int_{-L}^L \frac{k\lambda dx}{\sqrt{R^2 + x^2}}$$

Since the integral is even

$$V(R) = 2 \int_0^L \frac{k\lambda dx}{\sqrt{R^2 + x^2}}$$

(c) Look up the Integral: I looked this one up in my ancient integral table

$$\int \frac{dx}{\sqrt{R^2 + x^2}} = \sinh^{-1} \left(\frac{x}{R} \right) + C$$

(d) Use the integral formula:

$$V(R) = 2 \int_0^L \frac{k\lambda dx}{\sqrt{R^2 + x^2}} = 2k\lambda \left(\sinh^{-1} \left(\frac{x}{R} \right) \right) \Big|_0^L$$

$$V(R) = 2k\lambda \sinh^{-1} \left(\frac{L}{R} \right)$$

since $\sinh^{-1}(0) = 0$.

By symmetry we know the field is in the y direction. We can then calculate the field by taking the derivative of the potential

$$V(y) = -\frac{dV(y)}{dy} \hat{y}$$

Example 17.19 Calculate Field from Potential

Problem: Calculate the electric field along the y axis of a line charge with charge density λ and length $2L$ centered at the origin that lies along the y axis.

Solution

The potential calculated above was

$$V(R) = 2k\lambda \sinh^{-1} \left(\frac{L}{R} \right)$$

but since R is a distance along the y axis, this is equivalent to

$$V(y) = 2k\lambda \sinh^{-1} \left(\frac{L}{y} \right)$$

Since the potential only depends on y , the electric field along the y axis is

$$\vec{E} = -\frac{dV}{dy} \hat{y} = -2k\lambda \frac{d}{dy} \sinh^{-1} \left(\frac{L}{y} \right) \hat{y}$$

I looked up the derivative $d \sinh^{-1}(x)/dx = 1/\sqrt{1+x^2}$, so taking the derivative and using the chain rule,

$$\vec{E} = -2k\lambda \frac{d}{dy} \sinh^{-1} \left(\frac{L}{y} \right) \hat{y} = -2k\lambda \frac{1}{\sqrt{1+(L/y)^2}} \left(-\frac{L}{y^2} \right) \hat{y}$$

$$\vec{E} = \frac{2k\lambda L}{y\sqrt{y^2+L^2}} \hat{y}$$

If we take the limit, $L \gg y$, we get back the electric field of an infinite line charge, so we're OK.

17.5 Potential in Highly Symmetric Systems

We have been computing the electric field for complicated configurations of charge with Gauss' Law for some time. Now, we learn to compute the potential difference from the fields. No additional technique is required to calculate the potential difference in highly symmetric systems with conductors and dielectrics. The following points are however helpful to remember:

Only Field Matters: The presence of conductors or dielectrics only matters to the extent they effect the calculation of the electric field. Once you have a correct electric field everywhere, ignore the conductors and dielectrics in the potential calculation.

Same Deal Inside a Region: Inside of a region, there are no extra features. Compute the potential by integrating the field as usual.

Work Region by Region from Point A to Point B: If computing ΔV_{AB} along a path that crosses regions at points C and D , break the integral up into a sum over an integral across single regions

$$\Delta V_{AB} = \Delta V_{AC} + \Delta V_{CD} + \Delta V_{DB}$$

Be careful of the sign of potential difference across each region.

Example 17.20 Volume Charge Surrounded by Conductor

Problem: A volume charge with charge density ρ and radius a is centered at the origin. The volume charge is surrounded by an uncharged conductor of inner radius a and outer radius b as drawn to the right.

- Draw the electric field map. Draw any induced charge densities. Use your own paper.
- Compute the electric field everywhere.
- Compute the induced charge on the inner surface of the conductor.
- Compute the potential difference between ∞ and the origin.

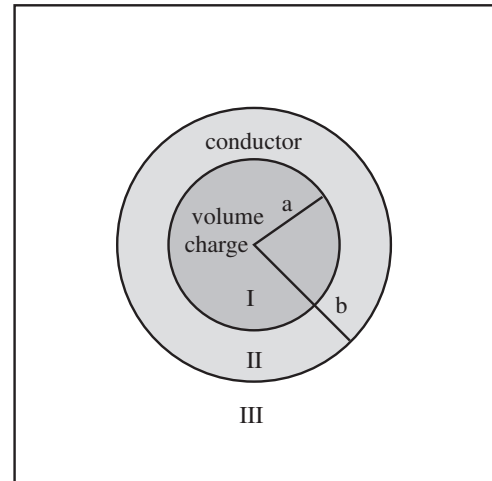

Solution to Part (a)

I chose four lines per total charge of the volume charge. These lines originate somewhere within the charge, stop on the conductor, and restart on the outer surface of the conductor.

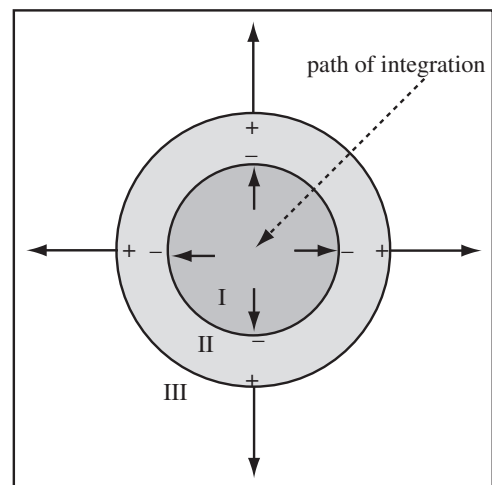

Solution to Part (b)

(a) Region I: The charge enclosed by a Gaussian surface of radius r in region I is

$$Q_{enc} = \frac{4}{3}\pi r^3 \rho$$

The electric field is given by the symmetry specific form of Gauss' Law

$$\vec{E}_I = \frac{Q_{enc}}{4\pi\epsilon_0 r^2} \hat{r} = \frac{\frac{4}{3}\pi r^3 \rho}{4\pi\epsilon_0 r^2} \hat{r} = \frac{\rho r}{3\epsilon_0} \hat{r}$$

(b) Region II: The electric field in the conductor is zero

$$\vec{E}_{II} = 0$$

(c) Region III: The charge enclosed by a Gaussian surface of radius r in region III is the total charge of the volume change, since the conductor is uncharged:

$$Q_{enc} = \frac{4}{3}\pi a^3 \rho$$

The electric field is given by the symmetry specific form of Gauss' Law

$$\vec{E}_{III} = \frac{Q_{enc}}{4\pi\epsilon_0 r^2} \hat{r} = \frac{\frac{4}{3}\pi a^3 \rho}{4\pi\epsilon_0 r^2} \hat{r}$$

Solution to Part (c)

A Gaussian surface in the conductor must enclose zero charge because the field is zero. Therefore, the charge on the inner surface of the conductor must be equal and opposite the charge of the volume charge

$$Q_{c,in} = -\frac{4}{3}\pi a^3 \rho$$

Solution to Part (d)

The path of integration points opposite the direction of the field, so all the potential differences are positive. The total potential difference from infinity to zero is

$$\Delta V_{\infty 0} = |\Delta V_I| + |\Delta V_{III}|$$

where I have used the potential difference across the conductor as zero. The potential difference across region III is

$$|\Delta V_{III}| = \left| - \int_{\infty}^b \vec{E}_{III} \cdot d\vec{\ell} \right| = \left| - \int_{\infty}^b \frac{\frac{4}{3}\pi a^3 \rho}{4\pi\epsilon_0 r^2} dr \right|$$

where I used $d\vec{\ell} = dr\hat{r}$ and $\hat{r} \cdot \hat{r} = 1$.

$$|\Delta V_{III}| = \left| \frac{\frac{4}{3}\pi a^3 \rho}{4\pi\epsilon_0 r} \Big|_{\infty}^b \right| = \frac{\frac{4}{3}\pi a^3 \rho}{4\pi\epsilon_0 b}$$

where I have correctly removed the absolute value to yield a positive number. Likewise, the potential difference across region I is

$$|\Delta V_I| = \left| - \int_a^0 \vec{E}_I \cdot d\vec{\ell} \right| = \left| - \int_a^0 \frac{\rho r}{3\epsilon_0} dr \right|$$

$$|\Delta V_I| = \left| - \frac{\rho r^2}{6\epsilon_0} \Big|_a^0 \right| = \frac{\rho a^2}{6\epsilon_0}$$

where once again the absolute value was removed to yield a potential with the correct sign. The total potential difference is then

$$\Delta V_{\infty 0} = |\Delta V_I| + |\Delta V_{III}| = \frac{\frac{4}{3}\pi a^3 \rho}{4\pi\epsilon_0 b} + \frac{\rho a^2}{6\epsilon_0}$$

which can be simplified to

$$\Delta V_{\infty 0} = \frac{a^3 \rho}{3\epsilon_0 b} + \frac{\rho a^2}{6\epsilon_0}$$

17.6 Electric Potential Energy and Motion

From the electric potential, we can calculate the electric potential energy of a charged particle moving in the field. The total energy of a system of charges is just another kind of energy. It is conserved and it can be converted into other forms of energy. First let us restate the law of conservation of energy and remind you of the kinetic energy of a moving particle.

Law of Conservation of Energy: As an *isolated* system undergoes changes, its total energy remains the same. This is a statement of the conservation of energy and relates the initial energy to the final energy

$$E_{\text{TOT}}^i = E_{\text{TOT}}^f$$

Kinetic Energy of a Point Mass: For a non-rotating or point mass, the kinetic energy is

$$K = \frac{1}{2}mv^2$$

where m is the mass and \vec{v} is the velocity.

The law of conservation of energy applies to all forms of energy. A system of charges brings a new type of energy to conserve, the electric potential energy. Let me remind you of the connection between potential and potential energy.

Electric Potential Energy: The electric potential energy, U , of a charge, q_0 , at some location \vec{r}_0 , is the electric potential at that point $V(\vec{r}_0)$ multiplied by the charge,

$$U = q_0V(\vec{r}_0)$$

Change in Electric Potential Energy: The change in electric potential energy ΔV_{AB} of a point charge q_0 when moved from a point A to a point B is

$$\Delta V_{AB} = q_0\Delta V_{AB} = U_B - U_A$$

where $U_A = q_0V_A$ and $U_B = q_0V_B$ are the electric potential energies of the charge at points A and B . The increase in potential energy is the work done on the charge by an external agent or its loss of kinetic energy.

Once the energies of the system are identified, we write a conservation equation which relates the energy of the system at one time to the energy of the system at another time.

General Conservation of Energy Equation: Energy is conserved between two times, t_i and t_f for the initial and final times, so the conservation of energy equation is:

$$K_i + U_i = K_f + U_f$$

where K is the kinetic energy and U is the potential energy. If the potential energy is only electric potential energy and there is only one charge moving q , this can be rewritten in terms of the electric potential,

$$K_i + qV_i = K_f + qV_f$$

where V_i and V_f are the electric potentials at the initial and final locations of the charge.

Conservation of Energy in Terms of Potential Difference: If a charge, q , moves from point A with velocity v_A to a point B with velocity v_B , the conservation of energy, if we knew the potential at point A , V_A , and point B , V_B , would be

$$\frac{1}{2}mv_A^2 + qV_A = \frac{1}{2}mv_B^2 + qV_B$$

We can rewrite this in terms of the potential difference, $\Delta V_{AB} = V_B - V_A$, as

$$\frac{1}{2}mv_A^2 = \frac{1}{2}mv_B^2 + q\Delta V_{AB}$$

After A Long Time: Potential problems will often ask for the energy or velocity after a long time or very far from the charge. You need to figure out where the particle will be after an infinitely long time, and use this location as the final location of the particle. If a particle is infinitely far away from a charge distribution of finite size whose reference point for potential energy is infinity, the particle has zero potential energy.

Example 17.21 Compute Change in Velocity from Electric Potential

Problem: A $1\mu\text{C}$ charge of mass 1g is released at a distance 5cm from another $1\mu\text{C}$ charge. How fast is it going after a long time?

Solution

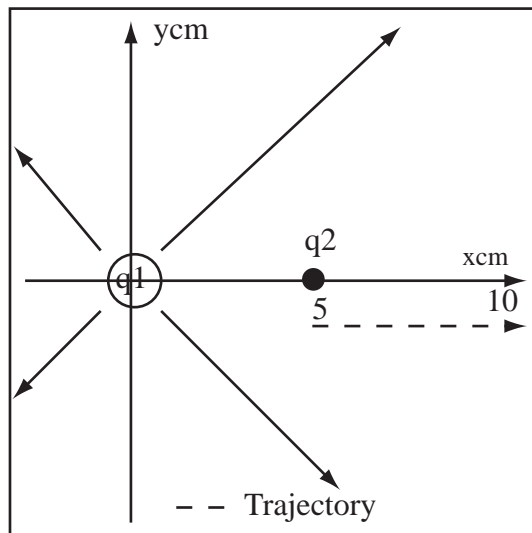

Definitions

- $q_1 \equiv$ Charge at origin
- $q_2 \equiv$ Charge moving
- $r_i = 5\text{cm} \equiv$ Initial separation
- $r_f \equiv$ Final Separation
- $V \equiv$ Electric Potential
- $v_i = 0 \equiv$ Initial Velocity
- $v_f \equiv$ Final Velocity
- $K_x \equiv$ Kinetic Energy at i and f
- $U_x \equiv$ Potential Energy at i and f
- $m = 1g \equiv$ mass moving

Strategy: Write conservation of energy equation and solve for v_f .

(a) Use Conservation of Energy: Because the electric force is conservative, the total energy when the particle is released is the same as the total energy after a long time. The total energy is the sum of the electric potential energy plus the kinetic energy.

$$K_i + U_i = K_f + U_f$$

(b) Understand Final State: At a very long time, the positive charge moves infinitely far away from the fixed positive charge, so $r_f \Rightarrow \infty$.

(c) Select proper form of KE and PE: The kinetic energy of q_2 is $K = \frac{1}{2}mv^2$. By definition of electric potential, $U = q_2V$.

$$\frac{1}{2}mv_i^2 + q_2V(r_i) = \frac{1}{2}mv_f^2 + q_2V(r_f)$$

(d) Select Proper Form of Potential: The electric potential of a point charge at the origin with $V(\infty) = 0$ is

$$V(r) = \frac{kq_1}{r}$$

(e) Substitute Initial and Final Conditions: In most problems, some terms of the conservation equation will simplify because of the initial and final conditions. Because the particle is released at $v_i = 0$, $K_i = 0$. Since $r_f \Rightarrow \infty$, $U_f \Rightarrow 0$, therefore

$$U_i = \frac{kq_1q_2}{r_i} = \frac{1}{2}mv_f^2 = K_f$$

(f) Solve for v_f :

$$v_f = \sqrt{\frac{2kq_1q_2}{mx_i}} = \sqrt{\frac{2(8.99 \times 10^9 \frac{\text{Nm}^2}{\text{C}^2})(1\mu\text{C})^2}{(0.05\text{m})(0.001\text{kg})}} = 19 \frac{\text{m}}{\text{s}}$$

Example 17.22 Smashing a Car Using Potential Energy

Problem: My former Geo Metro (man that car sucked) has mass $\approx 1000\text{kg}$. I apply a $+1\text{C}$ charge to the car (yes, that is a lot of charge). I place it against the exam room wall and let off the brake. Through ingenious use of chrome paint, I establish a potential difference of 1000V between the walls which are $d = 20\text{m}$ apart.

- Label the walls 0V and 1000V so that the car will accelerate from Wall 1 to Wall 2.
- After starting from rest, how much energy is released when it crashes into Wall 2?
- How fast is it going when it hits the wall?
- Will I succeed in destroying the car? ($1\frac{\text{m}}{\text{s}} = 2.2\text{mph}$) Justify your answer.

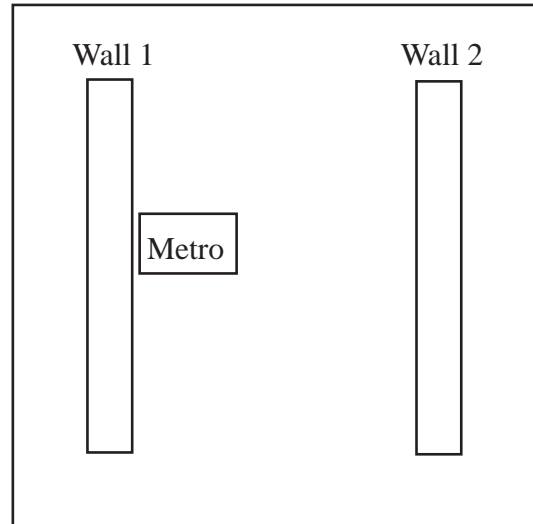

Solution to Part(a)

The charge on the car is positive so the electric field created by the charged walls must point from left to right. Therefore you must do work to move a positive test charge from wall 2 to wall 1, so wall 1 is at a higher potential. Wall 1 = 1000V . Wall 2 = 0V . We could also reason that a positive charge spontaneously moves to lower potential so Wall 1 must have higher potential than Wall 2.

Solution to Part(b)

The car's electric potential energy when it is at Wall 1 is converted into kinetic energy as it travels to Wall 2. This energy is released as heat and goes into deformation when the car crashes. By definition of electric potential, $|U| = |q\Delta V| = (1\text{C})(1000\text{V}) = 1000\text{J}$.

Solution to Part(c)

When it reaches the wall, it has lost 1000J of potential energy, which has been converted into kinetic energy so $-\Delta U = \frac{1}{2}mv^2$, where v is the velocity. Solving for v gives

$$v = \sqrt{\frac{2|\Delta U|}{m}} = \sqrt{\frac{2(1000\text{J})}{1000\text{kg}}} = 1.41\frac{\text{m}}{\text{s}}.$$

Solution to Part(d)

No. The car is only going 3mph .

Chapter 18

Electrostatic Energy

18.1 Electrostatic Energy

Since each charge exerts a force on every other charge, you have to do work to put a system of charge together. The total energy of a system of charges, E_{TOT} , is the total work you do to put it together. The part of this energy that is due to the potential energy of the electric fields is called the *total electrostatic energy*. This energy is stored in the electric fields.

In mechanics, when a spring was compressed by an external agent doing work against the force of the spring, we said the spring had potential energy. It is exactly the same situation with electric charge. An external agent must do work to bring each new charge in from infinity and place it at its location in the system. The total energy of a system E_{TOT} is equal to the total work W an external agent would have to do to assemble the system from scratch

$$E_{TOT} = W$$

The total energy is divided amongst many forms of energy, kinetic, potential, chemical, thermal, nuclear, etc. For this class, we will assume the energy is either kinetic K or electric potential energy U ,

$$E_{TOT} = K + U$$

The total electric potential energy of a system will be called the *total electrostatic energy*.

Energy Is Total Work: The total electrostatic energy of a system of stationary charges is the total work an external agent has to do to assemble it leaving each particle with zero kinetic energy. To compute the total energy, add the work required to add each charge.

Sign of the Energy: The energy is positive if you have to do work to put the system together, if you have to squeeze on it. The energy is negative if the system does work on you, if you have to hold onto it to keep it from going together.

Visualize Building It: To compute the total energy of a system of charges, imagine building it up charge by charge by hauling each charge, one at a time, in from infinity and gluing them in place.

Example 18.1 Reasoning about the Energy of a System of Charge

Problem: Positive and negative $1\mu C$ charges are 1cm apart. Is the total electrostatic energy of the system positive or negative? Justify your answer.

Solution

You can build this system by fixing the $+$ charge at the origin, and then bringing the negative charge in from infinity. As you bring the $-$ charge in, it is pulled toward the positive charge (Opposites Attract) doing work on you. Therefore you do negative work on the charge and the energy of the system is negative.

Example 18.2 Compute Energy of a Collection of Point Charges

Problem: Three $1\mu\text{C}$ point charges are spaced 10cm apart along the x -axis. Calculate the total electrostatic energy of the system.

Solution

Definitions
 $\vec{r}_{ij} \equiv$ Vector from i to j
 $q_i \equiv$ Charges

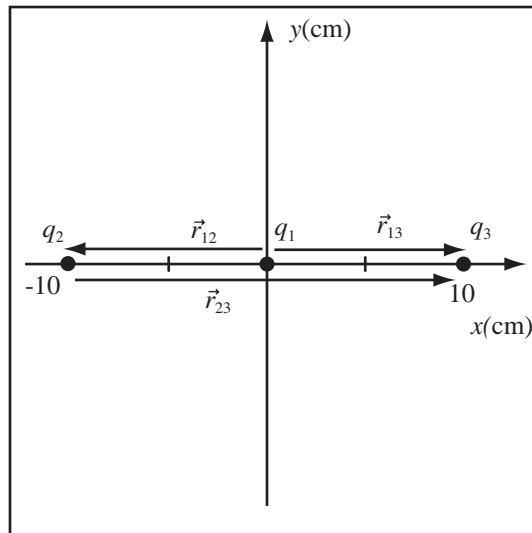
 $W_i \equiv$ Work to place charge i

Strategy: Bring one charge in from infinity at a time. Compute the work done (change in potential energy) as each charge is brought in. Add it all up.

(a) Write Total Work: We're going to assemble the system piece by piece and add up the work to place each new charge. The total electrostatic energy of the system, U , is the total work done to assemble the system which, is the sum of the work to place the individual charges. It doesn't matter in what order we place the charges, the total work will be the same. The total work to assemble the system is the work to place the first charge, W_1 , plus the work to place the second charge, W_2 , in the field of the first charge, plus the work to place the third charge, W_3 , in the field of q_1 and q_2 .

$$U = W_T = W_1 + W_2 + W_3$$

(b) Place First Charge: The work to place the first charge q_1 at location \vec{r}_1 is zero, $W_1 = 0$, since none of the other charges are present.

(c) Place Second Charge: Compute the work to place the second charge using the electric potential energy. The work to place q_2 in the electric field of q_1 (the only charge placed so far) is the change in potential energy to move q_2 in from infinity with q_1 fixed,

$$W_2 = q_2 \Delta V_1(\vec{r}_2) = q_2 \left(\frac{kq_1}{r_{12}} \right)$$

where I have used the potential difference between infinity and a point r from a point charge. The distance is $r_{12} = 10\text{cm}$ by observation. Substitute everything:

$$W_2 = \frac{kq_2q_1}{r_{12}} = \frac{(8.99 \times 10^9 \frac{\text{Nm}^2}{\text{C}^2})(1\mu\text{C})(1\mu\text{C})}{0.1\text{m}} = 0.09\text{J}$$

(d) Add the Third Charge: The work to place q_3 in the electric field of q_1 and q_2 is the change in potential energy to move q_3 in from infinity with q_1 and q_2 fixed,

$$W_3 = q_3 \left(\frac{kq_1}{r_{13}} \right) + q_3 \left(\frac{kq_2}{r_{23}} \right)$$

The distances are $r_{13} = 10\text{cm}$ and $r_{23} = 20\text{cm}$ by observation.

$$W_3 = \frac{(8.99 \times 10^9 \frac{\text{Nm}^2}{\text{C}^2})(1\mu\text{C})(1\mu\text{C})}{0.1\text{m}} + \frac{(8.99 \times 10^9 \frac{\text{Nm}^2}{\text{C}^2})(1\mu\text{C})(1\mu\text{C})}{0.2\text{m}}$$

$$= 0.09\text{J} + 0.045\text{J} = 0.135\text{J}$$

(e) **Substitute and Solve:** Substitute the individual energies into the total energy sum,

$$U = W_T = W_1 + W_2 + W_3$$

$$= 0 + 0.09\text{J} + 0.135\text{J}$$

$$U = 0.225\text{J}$$

18.2 Electrostatic Energy Density

So what happens with a continuous system, say two equal and opposite parallel planes of charge? You guessed it, we chop the system into little bits of size Δq and build the system piece by piece.

Consider two parallel planes. Each plane has area A and the separation between the planes is ℓ as shown to the right. We can build two equal and opposite parallel planes by moving chunks of charge Δq from the left plane to the right plane. The first chunk we move requires zero work since the field is zero. To move the second chunk we have to do work $\Delta q \Delta V$ where ΔV is the potential difference due to field produced by the first chunk. The electric field of equal and opposite parallel planes is σ/ϵ_0 . The charge density is the charge divided by the area, $\sigma = q/A$. Therefore the electric field is $E = q/(A\epsilon_0)$. Since the field is uniform, $\Delta V = E\ell = q\ell/\epsilon_0 A$. The total work to assemble a system with total charge Q is

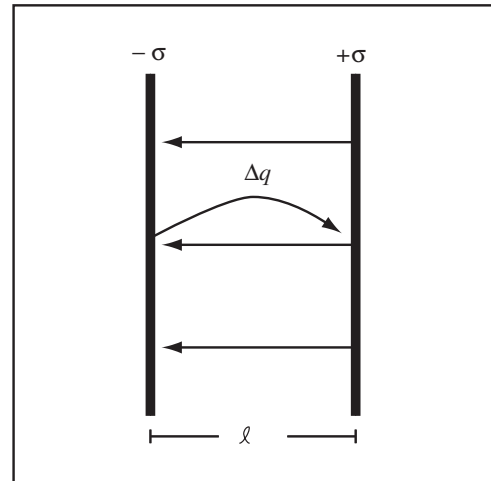

$$E_{TOT} = \sum \Delta q \Delta V = \sum \Delta q \frac{q\ell}{\epsilon_0 A} = \int_0^Q \frac{q\ell}{\epsilon_0 A} dq = \frac{Q^2 \ell}{2\epsilon_0 A}$$

This energy is stored in the electric field. The field is uniform, so the energy density must be uniform. The energy density is the energy divided by the volume $V = A\ell$ between the planes. Let u_e be the energy density of the electric field

$$u_e = \frac{E_{TOT}}{V} = \frac{\frac{Q^2 \ell}{2\epsilon_0 A}}{A\ell} = \frac{Q^2}{2\epsilon_0 A^2} = \frac{\sigma^2}{2\epsilon_0} = \frac{\epsilon_0 E^2}{2}$$

where I have used $E = \sigma/\epsilon_0$.

Electrostatic Energy Density: The energy per unit volume, u_e , stored in the electric field is

$$u_e = \frac{1}{2} \epsilon |E_0|^2,$$

where ϵ is the permittivity of the material (ϵ_0 for free space, $\epsilon = \kappa\epsilon_0$ for a material with dielectric constant κ .) and $|E_0|^2$ is the modulus of the electric field squared, $|E_0|^2 = \vec{E}_0 \cdot \vec{E}_0$.

This is rather profound. When we rubbed the golf tube with the oven bag, an electric field was produced which propagated out into the universe. That field carried energy, so when we rubbed the golf tube we sent a blast of energy travelling across the universe.

To calculate the total energy in some volume for a uniform field, multiply the energy density by the volume (if the field is uniform, the energy density is the same at all points in the volume).

Example 18.3 Energy in One Meter Cube at Earth's Surface

Problem: How much electrostatic energy is stored in a 1m cube at the Earth's surface. The electric field at the Earth's surface is 150N/C downward.

Solution

A 1m cube is so small compared to the Earth, that the field is approximately uniform in the cube. The energy of a region of the electric field is the energy density of the field $u_e = \frac{|\vec{E}|^2 \epsilon_0}{2}$, multiplied by the volume of the space, so

$$U = \frac{|\vec{E}|^2 \epsilon_0 V}{2} = \frac{(150 \frac{\text{N}}{\text{C}})^2 (8.85 \times 10^{-12} \frac{\text{C}^2}{\text{Nm}^2}) (1\text{m})^3}{2} = 9.96 \times 10^{-8} \text{J}$$

If the energy density changes with position, we have to integrate, natch.

Chapter 19

Capacitance

19.1 Definition of Capacitance

19.1.1 Definition of Capacitance

I love capacitance. Up to now, we have been computing things that can only be measured with expensive equipment that an engineer would probably not have access to in the field. Our hands-on experiments have yielded approximations to charge and field that are, at best, order of magnitude approximations. A capacitance meter costs about fifty bucks on-line. With capacitance, we can compute and measure charge, field, and the energy stored in the field with remarkable precision.

Definition Capacitance: The feature of electrostatic systems that enters into electric circuits is the capacitance C ; if equal and opposite charge $\pm Q$ are placed on two conductors a potential difference ΔV is produced. The capacitance of the system of conductors is

$$C = Q/\Delta V.$$

Capacitance is defined as the ratio of the charge on one of the conductors to the potential difference between two conductors carrying equal and opposite charge.

Capacitance Does Not Depend on Charge or Potential Difference: If the restrictions below are met, C does not depend on either Q or ΔV , but only on the geometry of the conductors and dielectrics, their size and shape, dielectric constants, and ϵ_0 . Capacitance is independent of Q and ΔV , if when all excess charge is removed from the conductors, there is no remaining charge or field in the system. That is, the conductors are not in the presence of fixed charge or external fields.

Units of Capacitance: The SI unit for capacitance is the farad F . The farad is related to other units by

$$1F = 1\frac{C}{V} = 1\frac{J}{V^2} = 1C^2/Nm$$

New Units for Permittivity: In capacitance problems it is often convenient to use $\epsilon_0 = 8.85 \times 10^{-12}F/m$.

Sizes of Capacitance: A conducting marble has a capacitance of $1pF = 1 \times 10^{-12}F$ with respect to ground. You have a capacitance of about $100pF$. Commercial capacitors often have a capacitance of $1mF = 1000\mu F = 1 \times 10^{-3}F$.

A capacitor is an electronic device used primarily for its capacitance. We will work with spherical, cylindrical, and parallel plate capacitors. A wire or a co-axial cable is a cylindrical capacitor and the capacitance per unit length of a cable is an important electrical property of the cable. Commercial capacitors however, are all formed of foils separated by a dielectric, which are all rolled up. They may be approximated as a parallel plate capacitors.

Capacitance of a Parallel Plate Capacitor: The capacitance of a parallel plate capacitor formed of two parallel conducting plates with plate area A and plate separation d is

$$C = \frac{\epsilon_0 A}{d}$$

Capacitance of Isolated Sphere: The capacitance of an isolated conducting sphere, with respect to ground, is

$$C = 4\pi\epsilon_0 R$$

where R is the radius of the sphere.

Example 19.1 Lab Capacitor Plate Area

Problem: The blue lab capacitors have a capacitance of $1000\mu\text{F}$. If they were air-filled parallel plate capacitors with plate separation, $0.1\text{mm} = 1 \times 10^{-4}\text{m}$, how much area would the plates have?

Solution

The capacitance of a parallel plate capacitor is given by

$$C = \frac{\epsilon_0 A}{d}$$

Solve for the plate area

$$A = \frac{dC}{\epsilon_0} = \frac{(1 \times 10^{-4}\text{m})(1000 \times 10^{-6}\text{F})}{8.85 \times 10^{-12} \frac{\text{C}^2}{\text{Nm}^2}}$$

$$A = 1.13 \times 10^4 \text{m}^2$$

19.1.2 Capacitance and Energy

Finally, the reason I really love capacitance is that it allows one to simply calculate the energy stored in systems of conductors, which is how I estimated the amount of energy which would be released if all the electrons were removed from a piece of charcoal on the first day of class.

You charge a two plate capacitor, establish equal and opposite charges on its plates, by using a source of potential difference, like a battery, to pump positive charge from the negative plate to the positive plate, or more physically pump negative charge from the positive plate to the negative plate as shown below.

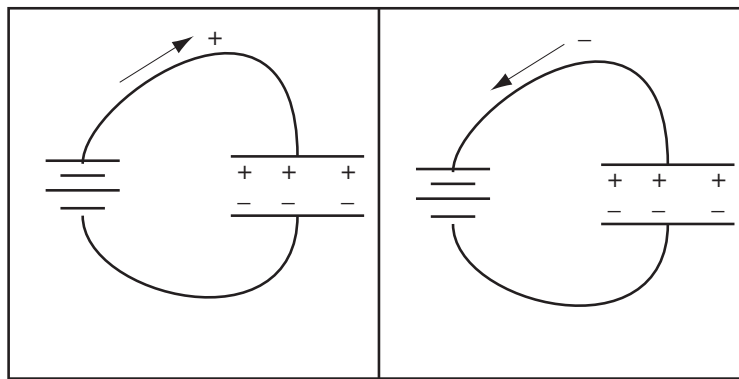

No charge actually passes between the plates. In the simplest capacitors, the area between the plates is filled with air and the only way charge can pass between the plates is through a spark. Once a capacitor sparks, it

is usually shot. Commercial capacitors are rated both by their capacitance and the maximum voltage they can support, ΔV_{max} . The maximum voltage is crucial to the amount of energy a capacitor can store.

A capacitor, when charged, has a positively charged plate separated from a negatively charged plate. To produce this separated charge an external agent had to do work, so the capacitor contains energy. We can imagine building the system of charge by moving chunks of charge from one plate to the other. This isn't what happens in practice and I'm not sure how you would actually do it, but for a thought experiment it is only important that it could be done in principle. The work to move the i th chunk Δq is $\Delta q \Delta V_i$ where ΔV_i is the potential difference the i th chunk is moved through.

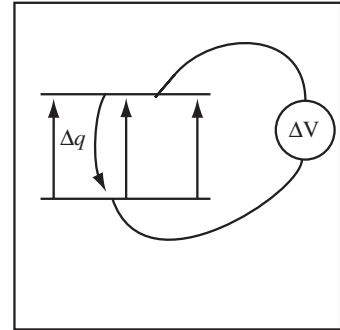

The total work to build up a charge of $+Q$ on one plate and $-Q$ on the other plate is

$$W = \sum_i \Delta q \Delta V_i = \sum_i \Delta q \frac{q_i}{C} = \int_0^Q \frac{q dq}{C} = \frac{1}{2} \frac{Q^2}{C}$$

where I used the definition of capacitance $C = Q/\Delta V$. This is one of my favorite formulas.

Energy of a Capacitor: The energy stored in a capacitor is

$$U = \frac{1}{2} Q \Delta V = \frac{1}{2} C \Delta V^2 = \frac{1}{2} \frac{Q^2}{C}$$

where each version of the formula is just a result of applying the definition of capacitance $C = Q/\Delta V$.

Example 19.2 Reasoning About Changes in Capacitor Properties with Voltage

Problem: A variable capacitor is connected to a power supply which maintains the capacitor at a constant potential difference.

- If the capacitance is increased, does the power supply deliver or remove positive charge from the positive capacitor plate?
- Is the energy that is stored in the capacitor increased or decreased?

Solution to Part(a)

Capacitance is the charge stored per potential difference, therefore capacitance multiplied by potential difference is the charge stored on one capacitor plate. If the capacitance increases, the charge stored on the positive plate increases, $Q = C \Delta V$.

Solution to Part(b)

The energy of a capacitor is given by the formula,

$$U = \frac{1}{2} C (\Delta V)^2.$$

If the capacitance increases, the energy stored increases.

Example 19.3 Finding Potential Difference Given the Energy of a Capacitor

Problem: A capacitor has a capacitance of $50.0 \mu\text{F}$ and can store 3.6 mJ of electrostatic energy when held at a certain potential difference. What is the potential difference necessary to accomplish this?

Solution

The energy stored in a capacitor is given by $U = \frac{1}{2}C\Delta V^2$, so the potential difference needed to store a given amount of energy is

$$\Delta V = \sqrt{\frac{2U}{C}} = \sqrt{\frac{2(3.6\text{mJ})}{50\mu\text{F}}} = 12\text{V}$$

I love capacitance because it allows us to calculate the energy of complicated systems without having to integrate the energy density over all space. A capacitor has charge densities and fields. If you want to calculate the energy of a system of charge and the charge and field of that system happens to match the charge and field of a capacitor you can use the energy of the capacitor to calculate the total energy of the system. After all, there is only charge and field. If an isolated spherical capacitor with respect the ground is charged to a charge Q , all that Q is at the surface of the sphere forming a surface charge density. The field in the sphere is zero and the field outside the sphere is $Q/4\pi\epsilon_0 r^2$. This is exactly the system of charge and field I calculated the total energy of at the end of last chapter by integrating the energy density. The capacitance of an isolated sphere is $C = 4\pi\epsilon_0 R$, where R is the radius. If I use the energy of a capacitor, I get a total energy of

$$U = \frac{1}{2} \frac{Q^2}{C} = \frac{1}{2} \frac{Q^2}{4\pi\epsilon_0 R} = \frac{Q^2}{8\pi\epsilon_0 R}$$

exactly what I calculated last chapter with a ton less work.

19.1.3 Effect of Dielectrics on Capacitance

We will compute the capacitance of many air-filled capacitors and measure a few with the lab capacitance meters. All commercial capacitors (except those funky variable capacitors you find in 1930s radios) have the space between the capacitor plates filled with some dielectric. The dielectric both insulates the two plates and increases the capacitance over some air-filled capacitor. The dielectric does this because it lowers the electric field, which lowers the potential difference for the same amount of charge, thus increasing the capacitance.

If a dielectric completely fills the area containing the electric field for a high symmetry system, like a parallel plate capacitor under the approximation that the plates are infinite parallel planes, the electric field is reduced by a factor of κ , the dielectric constant, for the same charge Q . The potential difference for a parallel plate capacitor is $E\ell$ where ℓ is the plate separation, so the potential difference changes from $\Delta V_0 = E_0\ell$ to $\Delta V_\kappa = E_0\ell/\kappa = \Delta V_0/\kappa$. The potential difference is reduced by a factor of κ . The capacitance changes from $C_0 = Q/\Delta V_0$ to $C_\kappa = Q/\Delta V_\kappa = \kappa Q/\Delta V_0 = \kappa C_0$. The capacitance is increased by a factor of κ .

Capacitance is Increased by a Dielectric : For a capacitor initially filled with air whose capacitance is C_0 , the effect of adding a material with a dielectric constant of κ is to increase the capacitance,

$$C_\kappa = \kappa C_0$$

The dielectric must completely fill any area with electric field.

Example 19.4 Reasoning about Charge in a Capacitor

Problem: A capacitor is charged to a potential ΔV_0 , and then disconnected. No charge leaks out. A dielectric with constant κ is then inserted.

- (a) What is the potential difference after the dielectric is inserted in terms of ΔV_0 ?
- (b) What is the capacitance in terms of the original capacitance C_0 ?
- (c) What is the charge on one of the plates in terms of the original charge Q_0 ?
- (d) What is the new energy in terms of the old energy U_0 ?

Solution to Part(a)

The electric field due to the charge is reduced by a factor of κ when the dielectric is inserted, therefore the potential difference is reduced by κ , $\Delta V = \Delta V_0/\kappa$.

Solution to Part(b)

The charge remains the same, so the new capacitance is $C = Q/\Delta V = \kappa Q/\Delta V_0 = \kappa C_0$. The capacitance is increased by a factor of κ .

Solution to Part(c)

The charge is unchanged so $Q = C_0\Delta V_0 = Q_0$.

Solution to Part(d)

The energy stored in a capacitor is $U = \frac{1}{2}Q\Delta V = \frac{1}{2}Q\Delta V_0/\kappa = U_0/\kappa$.

Example 19.5 Capacitance Change as Dielectric Inserted

Problem: An air-filled capacitor carries $|100\mu\text{C}|$ of charge on each plate. This produces a potential difference of 1.5V between the capacitor plates.

- (a) What is the capacitance of the capacitor?
- (b) If a dielectric with dielectric constant $\kappa = 4$ fills the air-space between the capacitor, what is the new capacitance?
- (c) What is the potential difference with the dielectric in place, if the charge on the plates is the same?

Solution to Part(a)

By definition of capacitance, $C = Q/\Delta V = (100\mu\text{C})/(1.5\text{V}) = 67\mu\text{F}$.

Solution to Part(b)

The dielectric increases the capacitance by a factor of κ , so the new capacitance is $C_\kappa = \kappa C = (4)(67\mu\text{F}) = 268\mu\text{F}$

Solution to Part(c)

Again by definition of capacitance, $\Delta V_\kappa = Q/C = (100\mu\text{C})/268\mu\text{F} = 0.38\text{V}$. We could have also used $\Delta V_0/\kappa$.

19.2 Capacitance from Electrostatics

19.2.1 Computing the Capacitance of a Two Conductor System

Many of you probably think of capacitance as a property of small devices you found as you tore apart your dad's hand-built stereo (hold it, that was me). Capacitance is a property of any system of conductors. It depends only on the geometry or shape of the conductors. Capacitance is measured between two conductors or between one conductor and the ground (which is as we've argued before, simply a large conductor). To compute the capacitance of a two conductor system, we follow a fixed process:

- Start with no net charge in the system.
- Add a charge $+Q$ to one of the conductors and $-Q$ to the other. Capacitance does not depend on the total charge of the system, so this arbitrary charge must cancel out of the capacitance.
- Compute the electric field, usually using Gauss' law.
- Compute the potential difference ΔV between the two conductors.
- Apply the definition of capacitance $C = Q/|\Delta V|$.

- Report a POSITIVE capacitance.

The following examples illustrate the two conductor case. The one conductor and ground case is covered later.

Example 19.6 Spherical Symmetry Capacitance

Problem: A spherical capacitor is formed by an inner core, conductor 1, with radius $r_1 = 5\text{cm}$ and an outer shell, conductor 3, with inner radius $r_4 = 20\text{cm}$. Between the inner core and the outer shell is a conducting shell, conductor 2, of inner radius $r_2 = 7.5\text{cm}$ and outer radius $r_3 = 17.5\text{cm}$. A charge Q is placed on the inner core and $-Q$ on the outer shell.

- What is the electric field in region I? Report a symbolic value.
- What is the electric field in region II? Report a symbolic value.
- What is the electric field in region III? Report a symbolic value.
- What is the potential difference between conductor 1 and conductor 2? Report a symbolic value.
- What is the potential difference between conductor 2 and conductor 3? Report a symbolic value.
- What is the capacitance between conductor 1 and conductor 3? Report both the symbolic and numeric values.

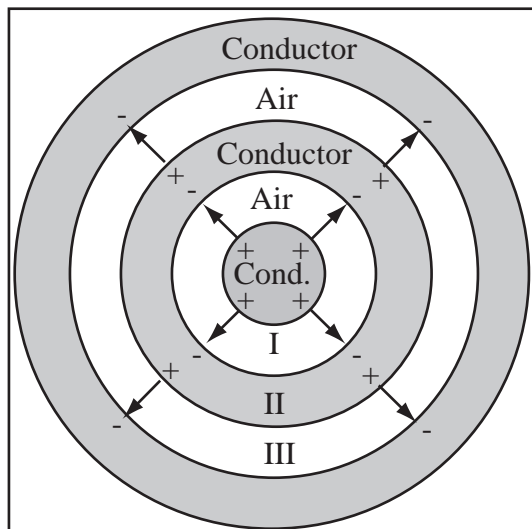
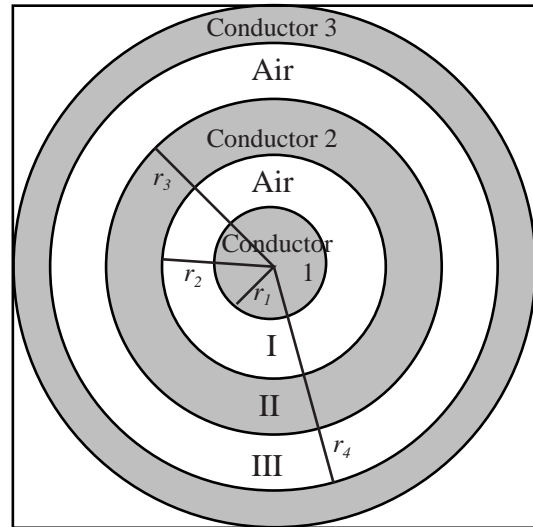

Strategy: Place $\pm Q$ charge on the inner and outer conductor. Compute the field using Gauss' Law, correcting for the presence of the region II conductor. Integrate the field to get the potential difference. Apply the definition of capacitance.

Solution to Part (a)

(a) Draw a Good Diagram: Select four field lines going out for the charge Q on the central conductor, so region I has four field lines. All these lines end on the conductor in region II and begin again on the outer surface of the conductor. Region III has four field lines since it encloses Q net charge.

Definitions

$Q \equiv$ Charge on conductor

$\vec{E}_i \equiv$ Electric Field in Region i

$\Delta V_i \equiv$ Potential Difference Across Region i

$C \equiv$ Capacitance

(b) Compute the Electric Field: The charge enclosed in region I is Q , so using Gauss' Law in spherical coordinates

$$\vec{E}_I = \frac{Q}{4\pi\epsilon_0 r^2} \hat{r}.$$

Solution to Part (b)

In region II, the field is zero because it is in a conductor,

$$\vec{E}_{II} = 0.$$

Solution to Part (c)

A Gaussian surface in region III encloses a charge Q . The electric field in region III has the same functional form as that in region I,

$$\vec{E}_{III} = \frac{Q}{4\pi\epsilon_0 r^2} \hat{r}.$$

Solution to Part (d)

Compute the Potential Difference Between the Inner Conductor and Middle Conductor: By definition of potential,

$$|\Delta V_I| = \left| - \int_{r_1}^{r_2} \vec{E}_I \cdot \hat{r} dr \right| = \left| - \int_{r_1}^{r_2} \frac{Q}{4\pi\epsilon_0 r^2} dr \right|$$

$$|\Delta V_I| = \left| \left(\frac{Q}{4\pi\epsilon_0 r} \right) \Big|_{r_1}^{r_2} \right| = \left| \frac{Q}{4\pi\epsilon_0} \left(\frac{1}{r_2} - \frac{1}{r_1} \right) \right|$$

Use a positive potential to yield a positive capacitance,

$$\Delta V_I = \frac{Q}{4\pi\epsilon_0} \left(\frac{1}{r_1} - \frac{1}{r_2} \right)$$

Solution to Part (e)

Compute the Potential Difference Between the Middle Conductor and the Outer Conductor: By definition of potential,

$$|\Delta V_{III}| = \left| - \int_{r_3}^{r_4} \vec{E}_{III} \cdot \hat{r} dr \right| = \left| - \int_{r_3}^{r_4} \frac{Q}{4\pi\epsilon_0 r^2} dr \right|$$

$$|\Delta V_{III}| = \left| \left(\frac{Q}{4\pi\epsilon_0 r} \right) \Big|_{r_3}^{r_4} \right| = \left| \frac{Q}{4\pi\epsilon_0} \left(\frac{1}{r_4} - \frac{1}{r_3} \right) \right|$$

Select a sign for the potential consistent with the choice for region I.

$$\Delta V_{III} = \frac{Q}{4\pi\epsilon_0} \left(\frac{1}{r_3} - \frac{1}{r_4} \right)$$

Solution to Part (f)

(a) Compute ΔV_{II} : The potential difference across the conductor is zero, $\Delta V_{II} = 0$

(b) Compute Total Potential Difference: Since the field points in the same direction in all regions the magnitudes of the potential difference add, so $\Delta V = \Delta V_I + \Delta V_{II} + \Delta V_{III}$.

$$\Delta V = \frac{Q}{4\pi\epsilon_0} \left(\frac{1}{r_1} - \frac{1}{r_2} \right) + 0 + \frac{Q}{4\pi\epsilon_0} \left(\frac{1}{r_3} - \frac{1}{r_4} \right)$$

(c) Apply Definition of Capacitance: The capacitance is defined as

$$C = \frac{Q}{\Delta V} = \frac{Q}{\frac{Q}{4\pi\epsilon_0} \left(\frac{1}{r_1} - \frac{1}{r_2} \right) + \frac{Q}{4\pi\epsilon_0} \left(\frac{1}{r_3} - \frac{1}{r_4} \right)}$$

$$C = \frac{4\pi\epsilon_0}{\left(\frac{1}{r_1} - \frac{1}{r_2}\right) + \left(\frac{1}{r_3} - \frac{1}{r_4}\right)}$$

$$C = \frac{4\pi\epsilon_0}{\left(\frac{1}{5\text{cm}} - \frac{1}{7.5\text{cm}}\right) + \left(\frac{1}{17.5\text{cm}} - \frac{1}{20\text{cm}}\right)}$$

$$C = 15.1\text{pF}$$

Example 19.7 Parallel Plate Capacitor with Dielectric Partially Filling Airspace

Problem: The conducting plates of a parallel plate capacitor each have an area of 2.0m^2 . They are separated by 4.0mm of air. A dielectric slab, with constant $\kappa = 2.5$ and width 2mm , is placed halfway between the plates. What is the capacitance of this arrangement?

Solution

Definitions

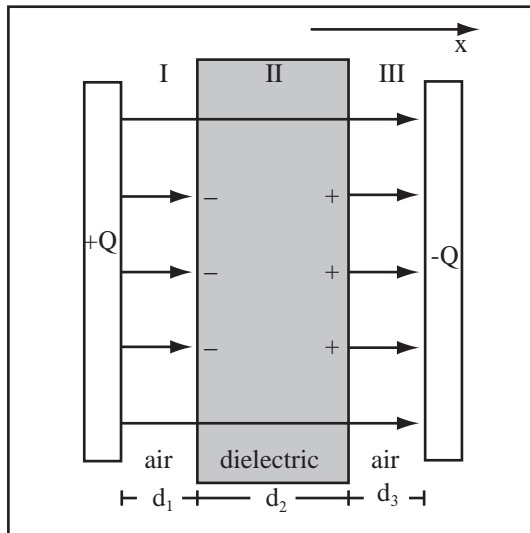

- $A = 2\text{m}^2 \equiv$ Area of Conducting Plate
- $\sigma \equiv$ Charge Density on Conducting Plate
- $\vec{E}_i \equiv$ Electric Field in Region i
- $\Delta V \equiv$ Potential Difference between Conductors
- $C \equiv$ Capacitance
- $\kappa = 2.5 \equiv$ Dielectric Constant
- $d_i \equiv$ Distance across region i

Strategy: Compute the electric field with the dielectric removed, then correct the field for the presence of the dielectric. Compute the potential difference using the formula for a uniform field, then apply the definition of capacitance.

(a) Place Charge on the Conductors: Place $+Q$ on the left conductor and $-Q$ on the right conductor. The area of the conductor is $A = 2\text{m}^2$, therefore the charge density on the left conductor is $\sigma = +Q/A$ and the charge density on the right conductor is $-\sigma = -Q/A$.

(b) Compute the Electric Field: Under the assumption that the plate area is infinite, the electric field of two equal and oppositely charged planes is

$$\vec{E}_0 = \frac{\sigma}{\epsilon_0} \hat{x} = \vec{E}_I = \vec{E}_{III}.$$

This can be computed either from Gauss' Law or by superimposing planes. This field is reduced in the dielectric by a factor of $\kappa = 2.5$,

$$\vec{E}_{II} = \frac{\sigma}{\kappa\epsilon_0} \hat{x}.$$

(c) Compute the Potential Difference between the Conductors: The potential difference across a region with uniform field, \vec{E} , is just $|\Delta V| = |E\Delta x|$, where Δx is the distance across the region. Since all of the fields point in the same direction, the potential difference between the conductors is

$$|\Delta V| = |E_I d_1| + |E_{II} d_2| + |E_{III} d_3|,$$

where $d_1 = 1\text{mm} = d_3$ and $d_2 = 2\text{mm}$.

$$|\Delta V| = \left| \frac{\sigma d_1}{\epsilon_0} \right| + \left| \frac{\sigma d_2}{\kappa \epsilon_0} \right| + \left| \frac{\sigma d_3}{\epsilon_0} \right|$$

Using $\sigma = Q/A$,

$$|\Delta V| = \frac{Q}{A\epsilon_0} \left(d_1 + \frac{d_2}{\kappa} + d_3 \right).$$

(d) **Apply Definition of Capacitance:** By definition,

$$C = \frac{Q}{\Delta V} = \frac{Q}{\frac{Q}{A\epsilon_0} \left(d_1 + \frac{d_2}{\kappa} + d_3 \right)}.$$

$$C = \frac{A\epsilon_0}{d_1 + \frac{d_2}{\kappa} + d_3} = \frac{(2\text{m}^2)(8.85 \times 10^{-12} \frac{\text{C}^2}{\text{Nm}^2})}{0.001\text{m} + \frac{0.002\text{m}}{2.5} + 0.001\text{m}}$$

$$C = 6.32 \times 10^{-9}\text{F} = 6.32\text{nF}$$

Example 19.8 Capacitance of a Co-axial Cable

Problem: I measured the capacitance of a length of co-axial cable. The cable was formed of two co-axial conductors. The inner conductor was a copper wire with outer radius a . The outer conductor was foil surrounded by a mesh shield and has inner radius b . Let L be the length of the cable.

- Compute the capacitance of an air-filled co-axial cable in terms of a , b , and L and constants.
- For the cable I measured, $a = 0.4\text{mm}$, $b = 2.2\text{mm}$, and $L = 3.05\text{m}$. Compute the capacitance if the cable had an air core.
- I measured a capacitance of about 170pF . The dielectric is foamed Teflon. Compute the dielectric constant of foamed Teflon.

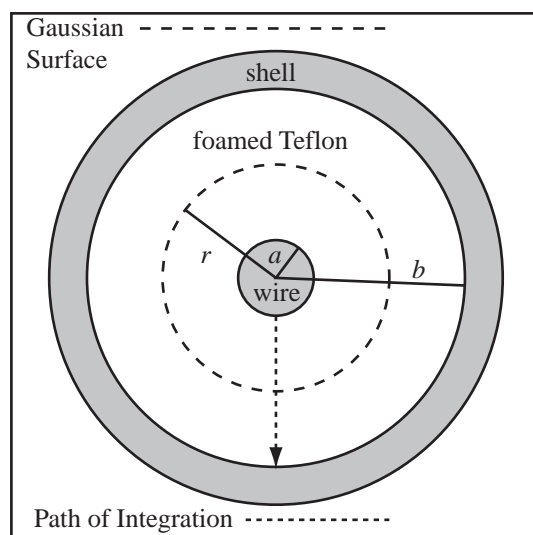

Definitions

- $a = 0.4\text{mm} \equiv$ Radius of inner wire
- $b = 2.2\text{mm} \equiv$ Inner radius of outer conducting shell
- $E_{II} \equiv$ Electric Field in region II
- $L = 3.05\text{m} \equiv$ Length of Cable
- $\ell \equiv$ Length of Gaussian Surface
- $Q \equiv$ Arbitrary Charge placed on Conductor
- $C \equiv$ Capacitance
- $r \equiv$ Radius from axis of system

Strategy: Introduce an arbitrary charge. Use Gauss' Law to compute the electric field, then apply the definition of electric potential to a path of integration between the conductors. Apply definition of capacitance.

Solution to Part (a)

(a) Place Charge on the inner and outer conductor: We will assume the cable is infinitely long to compute the electric field and potential difference. To compute the capacitance, we first place $+Q$ on the inner wire and $-Q$ on the outer shell. This creates a charge per unit length on the inner wire of $\lambda = Q/L$.

(b) Compute the Electric Field: For cylindrical geometry, Gauss' law reduces to

$$E = \frac{Q_{\text{enclosed}}}{2\pi\epsilon_0\ell r}$$

where ℓ is the length of the Gaussian cylinder. In region II , which is the only region where we need the field, the total charge enclosed in a Gaussian cylinder of length ℓ is $\lambda\ell = Q\ell/L$. So the electric field in region II if it were filled with air is

$$E_{II} = \frac{Q\ell/L}{2\pi\epsilon_0\ell r} = \frac{Q}{2\pi\epsilon_0 Lr}$$

(c) Compute the Potential Difference: The potential difference from the outer surface of the wire at radius a to the inner surface of the outer conductor at radius b is

$$\begin{aligned} |\Delta V_{ab}| &= \left| - \int_a^b \vec{E}_{II} \cdot \hat{r} dr \right| \\ &= \left| - \int_a^b \frac{Q}{2\pi\epsilon_0 Lr} dr \right| \\ |\Delta V_{ab}| &= \left| - \frac{Q}{2\pi\epsilon_0 L} \int_a^b \frac{dr}{r} \right| = \left| - \frac{Q}{2\pi\epsilon_0 L} (\ln(b) - \ln(a)) \right| \end{aligned}$$

(d) Apply Definition of Capacitance: By definition, the capacitance of the cable is

$$\begin{aligned} C &= \frac{Q}{|\Delta V_{ab}|} = \frac{Q}{\frac{Q}{2\pi\epsilon_0 L} (\ln(b) - \ln(a))} \\ C &= \frac{2\pi\epsilon_0 L}{\ln(b) - \ln(a)} = \frac{2\pi\epsilon_0 L}{\ln(b/a)} \end{aligned}$$

Solution to Part (b)

Compute the Capacitance of the Cable in Lab: Substitute the values measured for the cable in lab into the general expression derived above,

$$\begin{aligned} C &= \frac{2\pi\epsilon_0 L}{\ln(b/a)} = \frac{2\pi(8.85 \times 10^{-12} \frac{\text{C}^2}{\text{Nm}^2})(3.05\text{m})}{\ln(2.2\text{mm}/0.4\text{mm})} \\ C &= 99\text{pF} = 9.9 \times 10^{-11}\text{F} \end{aligned}$$

Solution to Part (c)

Compute the Dielectric Constant of Foamed Teflon: If the dielectric completely fills the region where the electric field exists, then the dielectric increases the capacitance from C to C_κ , where C_κ is the capacitance with the dielectric. Therefore the dielectric constant of foamed Teflon is

$$\kappa = \frac{C_\kappa}{C} = \frac{170\text{pF}}{99\text{pF}} = 1.71$$

Example 19.9 Parallel Plate Capacitor with Partially Filled Airspace

Problem: An electric field of $10000 \frac{\text{N}}{\text{C}}$ is established between the two parallel conductors shown in figure (a) below. The conductors are flat plates with area $A_p = 0.15\text{m}^2$ and separation $d = 2\text{cm}$.

- (a) If the field is established by connecting a power supply between the plates, what potential difference must the power supply provide?
- (b) What is the charge density on the left plate?
- (c) Draw the electric field and the location and sign of any bound charge in the system.
A dielectric slab of thickness $d/4$ with dielectric constant $\kappa = 3$ is inserted between the plates without disturbing the surface charge densities on either plate as shown in figure (b).
- (d) Compute the bound charge densities on the left and right surface of the dielectric, $\sigma_{b,l}$ and $\sigma_{b,r}$.
- (e) If the left and right plates are conductors, compute the capacitance of the system. Leave the answer symbolic, do not compute a number.

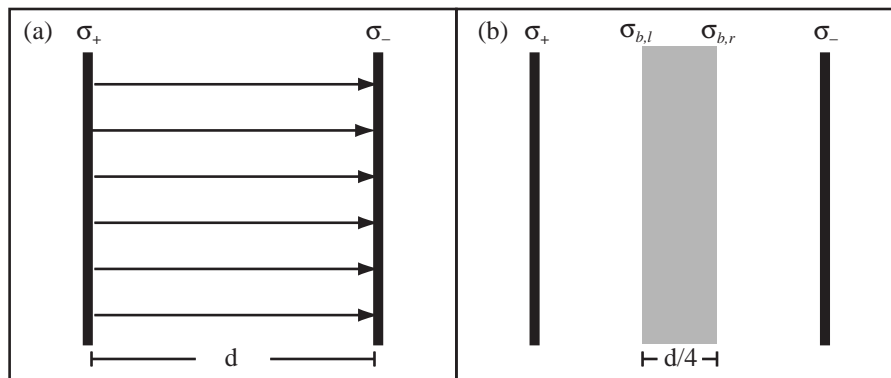

Solution to Part(a)

For a uniform field, the potential difference, ΔV , is related to the electric field, \vec{E} , by

$$|\Delta V| = |Ed| = (10000 \frac{\text{N}}{\text{C}})(0.02\text{m}) = 200\text{V}$$

where d is the separation of the plates.

Solution to Part(b)

The magnitude of the electric field of two equal and opposite planes of charge is

$$E = \frac{\sigma}{\epsilon_0}$$

Therefore the charge density on the left plate is

$$\sigma = \epsilon_0 E = (8.85 \times 10^{-12} \frac{\text{C}^2}{\text{Nm}^2})(10000 \frac{\text{N}}{\text{C}}) = 8.85 \times 10^{-8} \frac{\text{C}}{\text{m}^2}$$

Solution to Part(c)

The electric field outside of the dielectric is unchanged. The dielectric reduces the field in its interior by a factor of κ to 2 lines. Draw + where lines begin – where lines end.

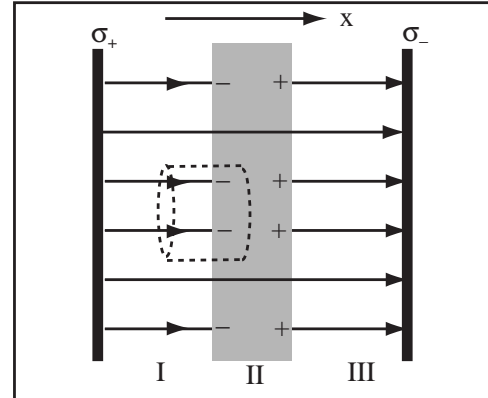

Solution to Part(d)

The system is divided into regions in the previous step and a cylindrical Gaussian surface with end area A is drawn. The electric field for the three regions are

$$\vec{E}_I = \vec{E}_{III} = \frac{\sigma}{\epsilon_0} \hat{x} \qquad \vec{E}_{II} = \frac{\sigma}{\kappa\epsilon_0} \hat{x}$$

Apply Gauss' law to the Gaussian surface drawn. Let $\vec{E}_I = E_I \hat{x}$ and $\vec{E}_{II} = E_{II} \hat{x}$.

$$E_{II}A - E_I A = \frac{Q_{\text{enclosed}}}{\epsilon_0}$$

The charge enclosed in the surface is the bound charge at the left side of the dielectric,

$$Q_{\text{enclosed}} = \sigma_{b,l} A$$

Substitute everything into Gauss' law

$$\frac{\sigma}{\kappa\epsilon_0} A - \frac{\sigma}{\epsilon_0} A = \frac{\sigma_{b,l} A}{\epsilon_0}$$

Cancel everything

$$\frac{\sigma}{\kappa} - \sigma = \sigma_{b,l}$$

By conservation of charge,

$$\sigma_{b,r} = -\sigma_{b,l} = \sigma - \frac{\sigma}{\kappa}$$

Solution to Part(e)

If the dielectric has thickness $d/4$ then the distance across region I and III is $\frac{d-d/4}{2} = \frac{3d}{8}$. The potential difference between the two plates is the sum of the potential differences across the regions. The potential difference across the single region is, because of the uniform field,

$$\Delta V_I = E_I \frac{3d}{8} = \frac{3d\sigma}{8\epsilon_0} = \Delta V_{III}$$

$$\Delta V_{II} = E_{II} \frac{d}{4} = \frac{d\sigma}{4\kappa\epsilon_0}$$

Therefore the total potential difference is

$$\Delta V = \Delta V_I + \Delta V_{II} + \Delta V_{III} = \frac{3d\sigma}{8\epsilon_0} + \frac{d\sigma}{4\kappa\epsilon_0} + \frac{3d\sigma}{8\epsilon_0}$$

The total charge, Q , on the plates is the plate area A_p multiplied by the charge density, $Q = \sigma A_p$. Apply the definition of capacitance,

$$C = \frac{\sigma A_p}{\frac{3d\sigma}{8\epsilon_0} + \frac{d\sigma}{4\kappa\epsilon_0} + \frac{3d\sigma}{8\epsilon_0}}$$

$$C = \frac{\epsilon_0 A_p}{d} \frac{1}{\frac{3}{4} + \frac{1}{4\kappa}}$$

19.2.2 Calculating the Capacitance of One Conductor and Ground

To compute the capacitance of one conductor and ground:

- Start with no net charge in the system.
- Add a charge $+Q$ to the conductor.
- Compute the electric field, usually using Gauss' law.
- Compute the potential difference ΔV between the conductor and infinity.
- Apply the definition of capacitance $C = Q/|\Delta V|$.
- Report a POSITIVE capacitance.

The capacitance of one parallel plate and the ground cannot be calculated, because the electric field of an infinite plane does not decay with distance, therefore the potential difference between an isolated infinite plane and infinity is infinite(four ∞ s in one sentence, a new record).

Example 19.10 Compute Capacitance of One Conductor and the Ground

Problem: What is the capacitance of a conducting sphere of radius 1.0m with respect to the ground (that is, zero potential)?

Solution

Definitions

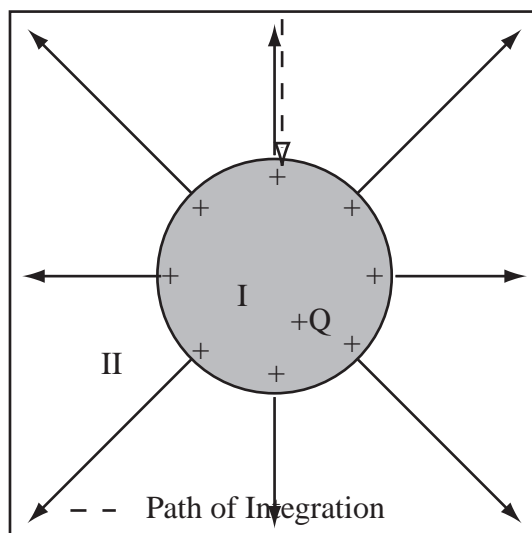

$R = 1m \equiv$ Radius of Sphere

$Q \equiv$ Charge on Sphere

$\vec{r} \equiv$ Radius Vector

$\Delta V \equiv$ Potential difference between sphere and ∞

$\vec{l} \equiv$ Path of integration

$C \equiv$ Capacitance of Sphere

Strategy: Place Q charge on the conductor, compute the electric field and integrate from infinity to the conductor to get the potential difference, and apply the definition of capacitance.

(a) Place Arbitrary Charge $+Q$ on the Conductor: Put a charge, Q , on the conductor.

(b) Compute the Field, \vec{E} : The electric field *outside* the conducting sphere is the same as that of a point charge, Q , located at the center.

$$\vec{E} = \frac{Q}{4\pi\epsilon_0 r^2} \hat{r}$$

(c) Integrate the Field to get ΔV : Integrate the electric field between the conductor and the ground to get the potential difference between the surface of the conductor and infinity. Draw the path on the diagram. Integrate the electric field from the zero potential at infinity to the surface of the conductor, r , to obtain the electric potential. By definition of electric potential

$$\Delta V = - \int_{path} \vec{E} \cdot d\vec{l}$$

Compute the magnitude, then select the sign to give a positive capacitance. For the path drawn on the diagram $d\vec{l} = \hat{r}dr$, the limits are R and ∞ ,

$$\begin{aligned} |\Delta V| &= \left| - \int_R^\infty \vec{E} \cdot (\hat{r}dr) \right| \\ &= \left| - \int_R^\infty \left(\frac{Q}{4\pi\epsilon_0 r^2} \hat{r} \right) \cdot (\hat{r}dr) \right| = \left| \frac{Q}{4\pi\epsilon_0} \int_R^\infty \frac{1}{r^2} dr \right| \\ &= \left| \frac{Q}{4\pi\epsilon_0} \left(-\frac{1}{r} \right) \Big|_R^\infty \right| \\ &= \left| \frac{Q}{4\pi\epsilon_0 R} \right| \end{aligned}$$

(d) Use Definition of Capacitance: By definition,

$$C = \frac{Q}{\Delta V} = \frac{Q}{Q/4\pi\epsilon_0 R} = 4\pi\epsilon_0 R$$

The charge Q you introduced had better cancel out or you have made a mistake.

(e) Substitute and Calculate:

$$C = 4\pi \left(8.85 \times 10^{-12} \frac{\text{C}^2}{\text{Nm}^2} \right) (1.0\text{m}) = 1.1 \times 10^{-10} \text{F} = 0.11\text{nF}$$

Chapter 20

Current and Resistance

20.1 Current

20.1.1 Current

Since the first day of this class, we have been moving electric charge from place to place. Previously, we have focused on the effects of moving charge so as to produce a net static charge. Now, we focus on the effects of moving charge through an electric field, where no net electric charge is produced. Suppose we place a conductor in an electric field, charge flows until the electric field in the conductor is zero as shown in figure (a) below. The field is zero because of the induced surface charge. Now, let's attach a pump and pump the induced charge away as fast as it is created. Since induced charge is equal and opposite, we can do this by pumping the + induced charge off the right side of the conductor, through the pump, and onto the left side of the conductor. Since there is no induced charge, there is an electric field in the conductor and a potential difference across the conductor. We will call a flow of charge an *electric current* and a system of conductors and other elements that potentially allow charge to flow, an *electric circuit*. A circuit is *closed* when charge flows and *open* when there is a barrier to charge flow.

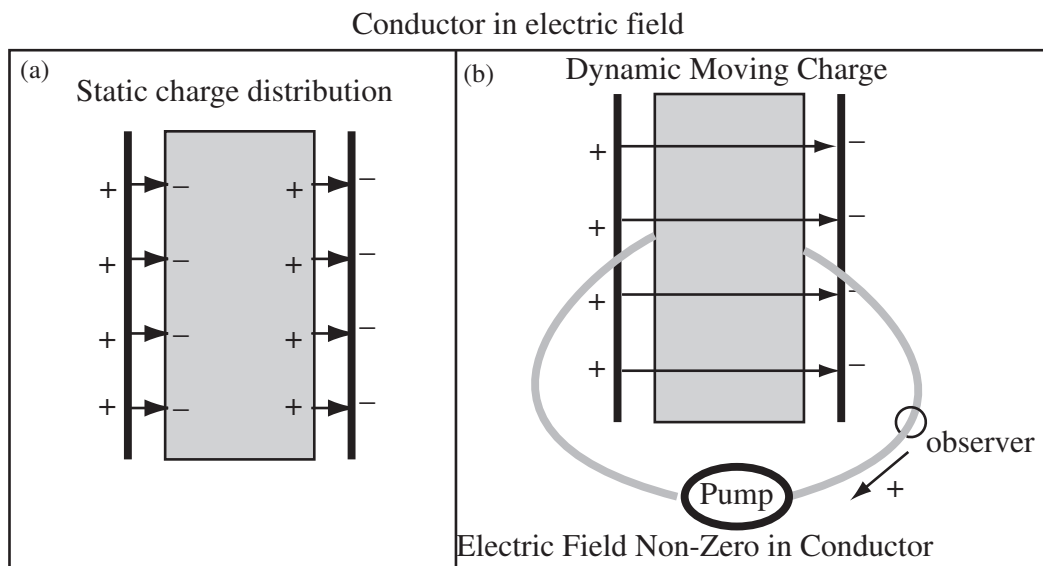

Suppose we have someone, an observer, measure how much charge ΔQ flows past some point in the circuit above in a time Δt . We define the electric current $I = \Delta Q / \Delta t$.

Definition of Current: Current, I , is defined to be the *rate* at which *positive* charge, Q , moves through a given cross-sectional area,

$$I = \frac{dQ}{dt}$$

where t is time. (The derivative is necessary to account for *changing* currents, whether in magnitude or direction). If the current is constant, we can write

$$I = \frac{\Delta Q}{\Delta t}$$

where a charge ΔQ moves through a cross-section in the time Δt .

Units for Current: The SI unit for current is the ampere, A. The ampere is related to other units by

$$1\text{A} = 1\frac{\text{C}}{\text{s}}$$

What does this mean? Figure (a) shows charged particles moving through space. In this case, the cross-section, labelled A , is a closed hoop in space. If a lightning bolt went through the center of a hula-hoop, it is a current through the hoop. Figure (b) shows charges flowing in a wire. In this case, the natural closed hoop to use for the current is the cross-section of the wire.

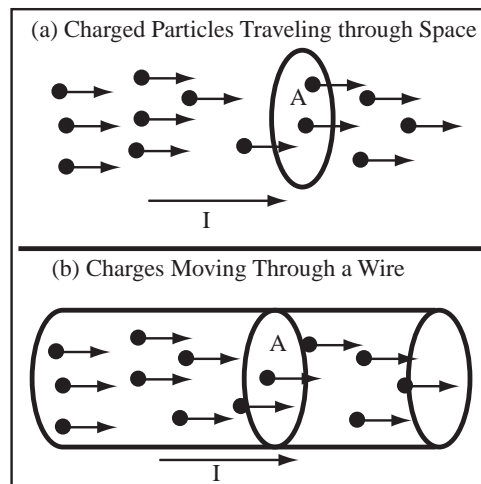

Positive Current is the Direction of Positive Charge Flow : Positive charge moving in a certain direction constitutes a positive current in that direction. Negative charge moving in the opposite direction also constitutes a positive current in that direction.

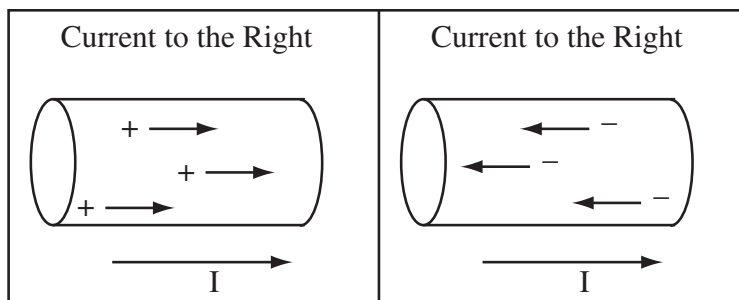

A current may be formed of charge particles moving through space or from charges moving in a wire. If the same amount of charge moves through a cross-section at the same time, the current is the same. There is one big difference, the charged particles moving through space have a net charge, and therefore an electric field. The current in the wire moves against the background of the positive atomic cores and the wire has no net charge, and no electric field.

Current Density: Currents flow in wires or in extended regions of space, we can define a current density j by dividing the current, I , by the area, A , its flowing through,

$$j = \frac{I}{A}$$

If you have the current density, the current is found by multiplying by the cross-sectional area.

The behavior of a electric circuit changes dramatically if the magnitude or direction of the current is changing with time.

DC Circuits: Direct Current (DC) circuits are circuits where the current always flows in the same direction.

The simple circuits we build with batteries and light bulbs in lab are direct current circuits.

Alternating Current Circuits: Alternating Current (AC) changes direction with time.

The current delivered from a wall plug is alternating current, a sine wave with frequency 60s^{-1} .

20.1.2 Circuit Diagrams and Measurement Tools

Most currents we deal with will flow in circuits, where the moving charge is confined to wires and other circuit elements. To represent these circuits concisely we will use circuit diagrams, cartoons of the circuit. We have already met circuit symbols for the ground and batteries. Let me introduce the symbol for a light bulb, ammeter, and voltmeter.

Light Bulbs: The more current that flows through a light-bulb, the brighter it glows. The circuit symbol for a light bulb is shown to the right.

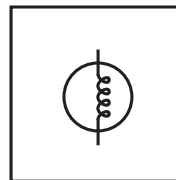

Circuit Symbol for Ammeter: An ammeter is an instrument used to measure current. The symbol for an ammeter is shown below. The instrument will read positive if a positive current goes in the + terminal and out of the - terminal. In our lab meters, the COM input is the - terminal. A perfect ammeter behaves as a wire in a circuit.

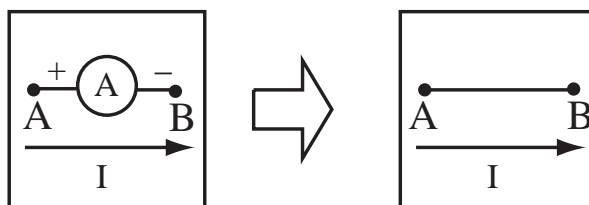

Circuit Symbol for Voltmeter: A voltmeter is an instrument to measure the potential difference between two points in an electric circuit. If the $+$ side of a voltmeter is connected to point B in a circuit and the $-$ side to point A , the voltmeter will read ΔV_{AB} . A perfect voltmeter does not draw any current from the circuit and behaves as a break in the circuit.

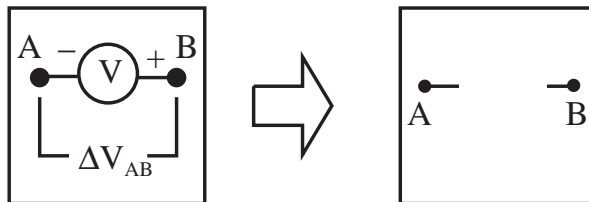

In Activity 12 Series and Parallel Circuits, we will build a simple circuit to light a light bulb with a battery. The figure below shows how the physical circuit is represented by a circuit diagram.

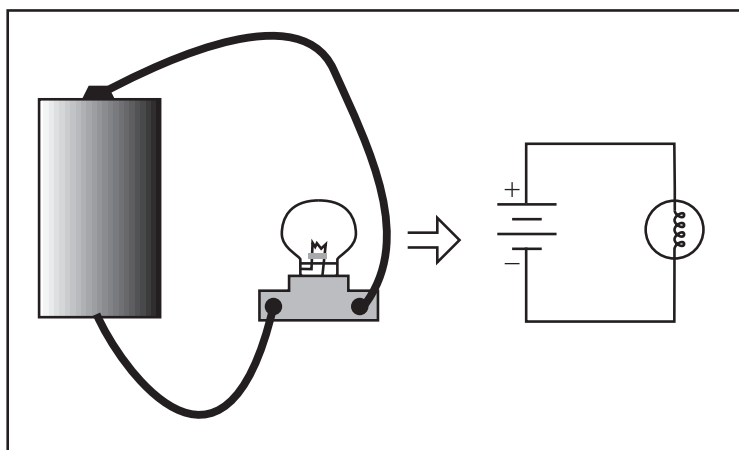

20.1.3 Potential Difference In Electric Circuits

We have some experience with the effects of relatively small static charges. The Van de Graaff establishes a charge of a few μC . The shorted “D”-cell battery circuit you built in lab carries a current of about $4A$. This means that $4C$ passes through any point in the circuit in a second. That is an incredible amount of charge. If any significant portion of this charge piled up at some point in the circuit as net charge, we would see lightning, sparks, and our hair would stand on end. We don’t see this, therefore net charge is not accumulating at any point in the circuit. If charge doesn’t accumulate and charge is conserved, the same current flows through all points of the circuit.

The figure to the right shows the same current flowing at all points in the bulb/battery circuit. The corners of the circuit have been labelled. Because the potential difference around any closed loop is zero, a basic law of the universe, we can write the sum of the potential differences around the circuit.

$$\Delta V_{AB} + \Delta V_{BC} + \Delta V_{CD} + \Delta V_{DA} = 0$$

The potential difference across a perfect conductor is zero even when it carries a current, therefore $\Delta V_{BC} = \Delta V_{DA} = 0$. If we connected voltmeters, we would find

$$\Delta V_{AB} = -\Delta V_{CD}$$

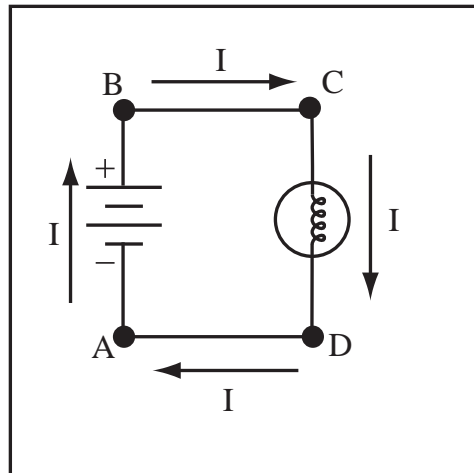

We have already said that the effect of a battery is to establish, ΔV_{batt} , voltage between the terminals of the battery. Therefore, from A to B , the potential difference is $\Delta V_{AB} = \Delta V_{batt} > 0$. The potential difference is positive, so the potential increases across the battery. This is called a *potential rise*. The reference point for the potential is any convenient point in the circuit, usually the negative side of the battery. If ΔV_{AB} is positive then ΔV_{CD} is negative. Therefore, the potential decreases from point C to point D . This is called a *potential drop*.

20.1.4 Power Dissipated/Provided to Electric Circuits

In the circuit above, a current I flows through non-zero potential differences $\Delta V_{AB} > 0$ and $\Delta V_{CD} < 0$. A charge moving from point A to point B through the battery goes from a point of lower potential to a point of higher potential. To move a charge, ΔQ , through a potential difference, ΔV_{AB} , an external agent must do work $\Delta Q \Delta V_{AB}$. The external agent in this case is the battery and it must provide this work for every charge in the current. If the current is $I = \Delta Q / \Delta t$, then the battery must provide work, ΔW , per time, Δt , of

$$\frac{\Delta W}{\Delta t} = \frac{\Delta Q \Delta V_{AB}}{\Delta t} = I \Delta V_{AB}$$

Work per unit time is power, P . The analysis above depended only on charge moving through potential difference and is completely general.

Power Dissipated by a Current: The rate at which energy is dissipated or stored in an object in a circuit is the product of the current flowing through the object and the potential difference across the object

$$P = I \Delta V.$$

This is also the expression for the power provided by the batteries and capacitors in a circuit.

Definition of Power: Power, denoted by the symbol P , is the rate of doing work or providing energy.

Units of Power: The units of power are Watts and are related to other units by

$$1\text{W} = 1 \frac{\text{J}}{\text{s}}$$

Energy and Power: Power is energy per unit time. If a device provides or consumes power, P , at a constant rate, then the energy provided or consumed by the device in time t is

$$U = Pt$$

If the power changes with time, $P(t)$, the energy provided becomes

$$U = \int P(t)dt$$

A battery or capacitor provides energy to a circuit when the current flows from lower to higher potential. A battery removes energy from the circuit when the current flows from higher to lower potential. When a battery or capacitor removes energy from the circuit, the energy is stored. We call this *charging* the battery or capacitor.

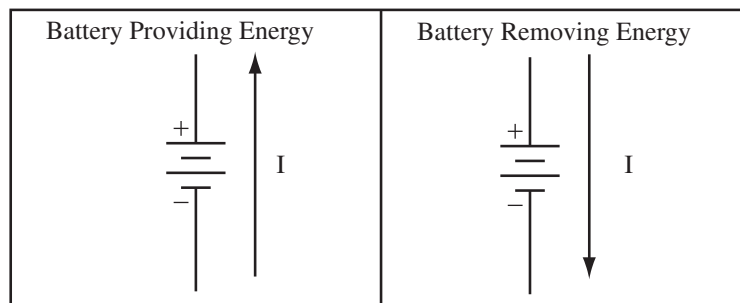

The sign of the potential difference, ΔV_{CD} , as the current goes through the light bulb is negative, the light bulb does negative work on the current, or equivalently, the current does positive work on the light bulb. The current provides energy to the light bulb that the bulb turns into heat and light. This energy is lost to the environment and the light bulb is said to *dissipate energy*. The rate at which the energy is lost is the power. We'll be sloppy and talk about power dissipated, but what that will mean is, the rate at which the energy is dissipated.

Conservation of Energy for Circuits: Energy is conserved. The power provided, P_{in} , to a circuit must equal the power dissipated by a circuit, P_{out} , added to the power stored in the circuit, P_{stored} ,

$$P_{in} = P_{out} + P_{stored}$$

Energy may be stored by running a current backward through a battery or using a capacitor.

20.2 Resistance and Resistivity

20.2.1 Resistance

When an electric current flows in a material, the material resists the flow of current. All materials (except superconductors) resist the flow of current.

Definition of Resistance: The ratio of the potential difference (ΔV) across a material to the electric current (I) through that material is defined as the resistance (R) of the material

$$R \equiv \frac{\Delta V}{I}.$$

Important note: In general, this ratio (and therefore the resistance) changes as current changes.

Units for Resistance: The SI unit for resistance is the ohm Ω . The ohm is related to other units by

$$1\Omega = 1\frac{\text{V}}{\text{A}}$$

Resistance Meter: A resistance meter, one of the settings on the lab multimeter, measures resistance by passing a small current through a circuit and measuring the voltage. If the resistance of the object changes with current, it reads the resistance for the meter current.

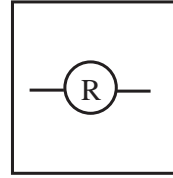

Example 20.1 Computing Resistance from its Definition

Problem: You observe that a block of carbon will draw $1\mu\text{A}$ of current when 6V is applied between points A and B. What is the resistance of the block between points A and B?

Solution

The resistance is defined as $R = \Delta V/I = 6\text{V}/(1 \times 10^{-6}\text{A}) = 6 \times 10^6\Omega$

We can use the definition of resistance in the general expression for power.

Power Dissipated by a Resistive Element: Consider a circuit element with resistance, R , through which a current (I) flows caused by a potential difference (ΔV) across the element. Some of the energy of the current is converted into heat. Using the general definition of power and the definition of resistance gives

$$P = I\Delta V = I^2R$$

Example 20.2 Resistance of a Light Bulb

Problem: In the US, house wiring delivers 110V . A standard light bulb consumes 100W of power.

- (a) How much current does the light bulb draw?
- (b) During operation, what is the light bulb's resistance?

Solution to Part(a)

The power dissipated by any device is always $P = I\Delta V$, so $I = P/\Delta V = 100\text{W}/110\text{V} = 0.91\text{A}$.

Solution to Part(b)

A light bulb's resistance changes as it heats up, so the resistance you measure when it's cold is different than its operating resistance, therefore the light bulb does not obey Ohm's Law. The definition of resistance still applies though. This light bulb's resistance at its operating temperature is, by Definition of Resistance, $R = \Delta V/I = 110\text{V}/0.91\text{A} = 121\Omega$

20.2.2 Resistance of Materials

The amount of resistance depends on the shape of the conductor. Wires with larger cross-sections have lower resistance, dissipate less power, and generate less heat for the same current than narrower wires. A longer cable has higher resistance than a shorter cable. The intrinsic feature of the material which resists current flow is called its resistivity ρ . (Yes, we are running out of Greek letters and yes, you can only tell ρ for resistivity from ρ for volume charge density by context.)

We can understand resistance in terms of our charge-pumping model at the beginning of the chapter. Suppose we have a conductor of length ℓ and cross-section A which is part of an electric circuit. A potential difference, ΔV , is applied across the conductor. If the field is assumed uniform, the electric field in the conductor is $E = \Delta V/\ell$. This electric field causes the mobile charges in the conductor to accelerate. If the mobile charges have charge, q , then the force on each charge is $F = qE$ and the acceleration is $a = F/m = qE/m$. If the charges start from rest, then their velocity after time t is $v = at$.

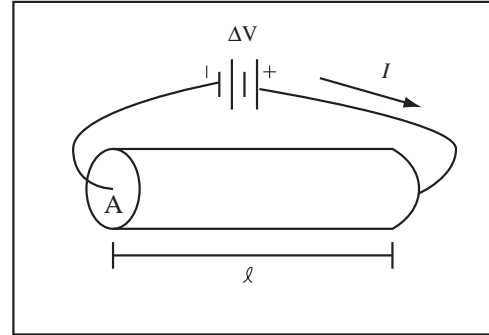

Eventually, the charges must smash into something or the velocity would become infinite. Let the time τ be the average time the charge has been travelling since its last collision. The average velocity of the charges is

$$v_d = a\tau = \frac{qE\tau}{m} = \frac{q\Delta V\tau}{m\ell}$$

and is called the *drift velocity*. If the density of mobile charges is n , then the current density in the material is $j = qnv_d$ and the total current in the conductor

$$I = jA = qnv_dA = \frac{nq^2\Delta V\tau A}{m\ell}$$

Rearranging gives,

$$\frac{\Delta V}{I} = R = \left(\frac{m}{nq^2\tau} \right) \frac{\ell}{A}$$

where I have used the definition of resistance. The stuff in parenthesis does not depend on the shape of the conductor. It represents the conductive material's intrinsic resistance, and is called the resistivity, ρ ,

$$\rho = \left(\frac{m}{nq^2\tau} \right)$$

So as the number of charge carriers goes up the resistance goes down. As the time between collisions goes up the resistance goes down. As temperature increases, the atoms of the metal shake around more, and the moving charges collide more often. Therefore, resistance increases with temperature.

Calculation of Resistance from Resistivity: The intrinsic feature of the material which resists current flow is called its resistivity, ρ . The cross-sectional area, A , of the material and the distance, L , through which the current flows also play a role in determining the resistance of a material. The resistance of a material whose resistivity is independent of current is related to its geometry by

$$R = \rho \frac{L}{A}$$

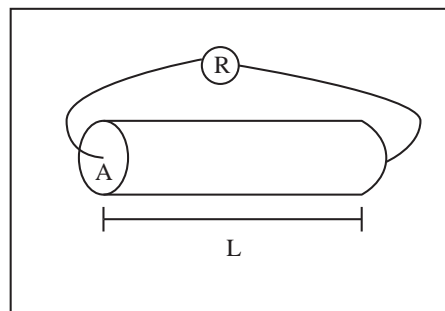

Temperature Dependence of Resistivity : In general, the resistivity will change with environmental conditions, particularly temperature. It will be a number that must be looked up in a table or given in the question. If no temperature is specified, the results will be for 20°C .

Resistivity

Type	Name	Resistivity (20°C)	Resistivity (900°K)
Conductor	Copper	$1.67 \times 10^{-8}\Omega\text{m}$	$6.04 \times 10^{-8}\Omega\text{m}$
	Aluminum	$2.65 \times 10^{-8}\Omega\text{m}$	$10.18 \times 10^{-8}\Omega\text{m}$
	Silver	$1.59 \times 10^{-8}\Omega\text{m}$	$5.64 \times 10^{-8}\Omega\text{m}$
	Stainless Steel	$72 \times 10^{-8}\Omega\text{m}$	
Semi-Conductor	Silicon	$1 \times 10^{-3}\Omega\text{m}$	
Insulator	Cellulose	$10^8 - 10^{10}\Omega\text{m}$	
	Polypropylene	$> 10^{13}\Omega\text{m}$	
	Teflon	$> 10^{16}\Omega\text{m}$	

Example 20.3 Comparing the Resistances of Wires

Problem: Wire A has twice the radius and half the length of wire B ; both are made from the same material. How is the resistance, R_A , of wire A related to the resistance, R_B , of wire B ?

Solution

Let L_A be the length of wire A and $L_B = 2L_A$ the length of wire B . Let r_A be the radius of wire A and $r_B = r_A/2$. The resistance of a wire is given in terms of the resistivity, ρ , by $R = \frac{\rho L}{A}$, so the resistance of wire A is

$$R_A = \frac{\rho L_A}{A_A} = \frac{\rho L_A}{\pi r_A^2}$$

$$R_B = \frac{\rho L_B}{A_B} = \frac{\rho L_B}{\pi r_B^2} = \frac{\rho 2L_A}{\pi (r_A/2)^2} = 8 \frac{\rho L_A}{\pi r_A^2}$$

$$R_A = \frac{1}{8} R_B$$

Example 20.4 Resistance of An Iron Bar

Problem: A rectangular bar of iron has width 1cm and height 1cm. The bar is 3m long. Iron has resistivity $10 \times 10^{-8}\Omega\text{m}$. What is the resistance of the bar along the long dimension?

Solution

The resistance is given by

$$R = \frac{\rho L}{A} = \frac{(10 \times 10^{-8}\Omega\text{m})(3\text{m})}{(0.01\text{m})^2} = 3 \times 10^{-3}\Omega$$

where A is the area of the end and L is the length.

20.2.3 But that's all garbage

A mental model of electrons barrelling through a material under the influence of the electric field and crashing into stuff is kind of intuitive. The problem is when you go measure anything in the model presented above the numbers you come up with are Martian. For example, it seems obvious that the value of the charge moving is $q = -e$, the charge of the electron. If you make the measurement you find different values for the charge in different materials, some positive some negative. Likewise, the mass of the object moving does not turn out to be the mass of the electron. If you make models of how fast the charges should be moving based on the theory of gases, you're off by miles.

Conduction and resistance are intrinsically quantum mechanical phenomena. The mobile electrons travel as waves through the material. To a first approximation the mobile electrons completely ignore the atoms and other mobile electrons. They have the energies associated with a single free particle trapped in a box, where the conductor is the box. Just like filling up atomic orbitals in chemistry, two conduction electrons cannot occupy the same state, by the Pauli exclusion principle. So as conduction electrons are added to the system, each must be added to a different state, with ever increasing energy. So what we actually have is a quantum mechanical gas of Avogadro's number of electrons pretending each other aren't there.

The crystal structure of the metal further complicates things. The waves become grouped into energy *bands*. Filled bands are insulating. Partially filled bands allow conduction. Since bands are filled in order of energy, only the highest energy band conducts and is called the *conduction band*. Sometimes the conduction band is mostly empty, populated only by charges that are thermally excited from a lower band. Since the conduction band is mostly empty, the density of charge carriers is low, and the material is a conductor, but a poor conductor or *semi-conductor*. Semi-conductors have been very important technically because their conduction properties can be adjusted by adding impurities. This process is called *doping*.

Chapter 21

DC Circuits

21.1 Ohm's Law

21.1.1 Ohm's Law

As we saw last chapter, a material's resistance changes with temperature. It is sometimes the case that this change is small over the operating range of a device or system. If a device's resistance over a range of different currents is constant, the object is said to be *ohmic* and obeys Ohm's law. A light bulb is not ohmic because if you plot the voltage across the light bulb against the current through the light bulb you get a curve like the curve shown below. In electric circuits, devices where the voltage vs. current curve is a straight line, called resistors, are common. The voltage-current plot for a resistor is drawn below. Since voltage over current is resistance, light bulbs have a variable resistance, while resistors have a constant resistance.

Voltage vs. Current for Light Bulb

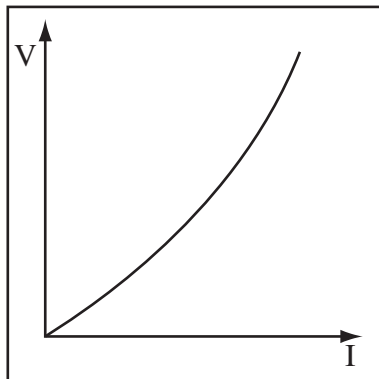

Voltage vs. Current for Resistor

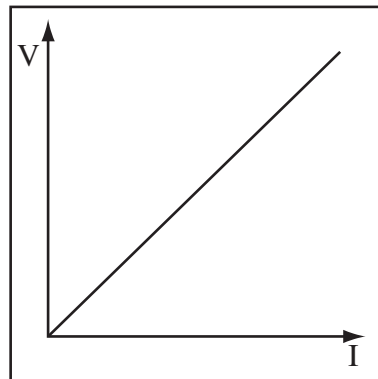

Ohm's Law: In some cases, the resistance of a material remains constant as the potential difference or current is changed. In such cases, the material obeys an experimental relationship called Ohm's Law

$$\Delta V = IR$$

Resistance Abbreviations: Resistances are often large numbers. We will use the following abbreviations for large resistances:

$$1\text{K}\Omega = 1 \times 10^3\Omega \quad \text{kilo-ohms}$$

$$1\text{M}\Omega = 1 \times 10^6\Omega \quad \text{mega-ohms}$$

Resistor Circuit Symbol: The symbol which represents a resistor, which is a circuit device that obeys Ohm's law, is shown to the right.

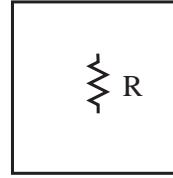

Recognize when Ohm's Law is valid : Ohm's Law is an experimental law and is valid only for materials which have a constant resistance for varying potential differences across them. If the ratio $\Delta V/I$ is not constant for the material in question, the material is not Ohmic and does not obey Ohm's Law.

Example 21.1 Ohm's Law Example

Problem: A $4.0\text{M}\Omega$ resistor is connected across a 12V battery.

- (a) What is the current through the resistor?
- (b) What is the power dissipated by the resistor?
- (c) How much heat is dissipated by the resistor in 3s?

Solution to Part(a)

Convert the units on resistance, $4.0\text{M}\Omega = 4.0 \times 10^6\Omega$. Apply Ohm's law,

$$I = \frac{\Delta V}{R} = \frac{12\text{V}}{4.0 \times 10^6\Omega} = 3 \times 10^{-6}\text{A} = 3\mu\text{A}$$

Solution to Part(b)

The power dissipated by an element is always $P = I\Delta V$. If we substitute Ohm's law,

$$P = I\Delta V = I^2R = (3 \times 10^{-6}\text{A})^2(4.0 \times 10^6\Omega) = 36 \times 10^{-6}\text{W}$$

Solution to Part(c)

Since the power is constant, the energy dissipated, U , is Power multiplied by time

$$U = (36 \times 10^{-6}\text{W})(3\text{s}) = 1.08 \times 10^{-4}\text{J}$$

Example 21.2 Wrench and Car Battery

Problem: While working on your car, you accidentally short your battery with a wrench, which we will approximate as a 1cm diameter iron cylinder, 20cm long. The battery delivers 600A. The resistivity of iron is $10 \times 10^{-8}\Omega\text{m}$. How much heat energy is generated per second?

Solution

The resistance of the wrench is $R = \frac{\rho L}{A}$, where ρ is the resistivity, $L = 20\text{cm}$ is the length, and $A = \pi r^2 = \pi(0.5\text{cm})^2 = 7.8 \times 10^{-5}\text{m}^2$ giving a resistance of

$$R = \frac{\rho L}{A} = \frac{(10 \times 10^{-8}\Omega\text{m})(0.2\text{m})}{7.8 \times 10^{-5}\text{m}^2} = 2.55 \times 10^{-4}\Omega$$

The power dissipated by the wrench is given by

$$P = I^2R = (600\text{A})^2(2.55 \times 10^{-4}\Omega) = 91.8\text{W}$$

Note this is not your biggest problem. The voltage drop across the wrench is

$$\Delta V_{wrench} = IR = (600\text{A})(2.55 \times 10^{-4}\Omega) = 0.153\text{V}$$

A car battery has potential difference 12V, so $12\text{V} - 0.153\text{V} = 11.85\text{V}$ drops across the internal resistance within the battery. Therefore the heat energy deposited in the battery per second is

$$\Delta VI = (11.85\text{V})(600\text{A}) = 7110\text{W}$$

All this energy is heating the sulfuric acid in the battery, which will hurt when it hits you in the face.

21.1.2 Physical Batteries

A perfect battery maintains a potential difference ΔV_{batt} across its terminals regardless of how much current it delivers. The potential difference across a real battery, called the terminal voltage ΔV_{term} , decreases as more current is provided.

Physical Batteries: A real battery can be modelled as a perfect battery with potential difference ΔV_{batt} in series with a resistor whose resistance is called the internal resistance and is given the symbol R . A physical “D”-cell is drawn to the right.

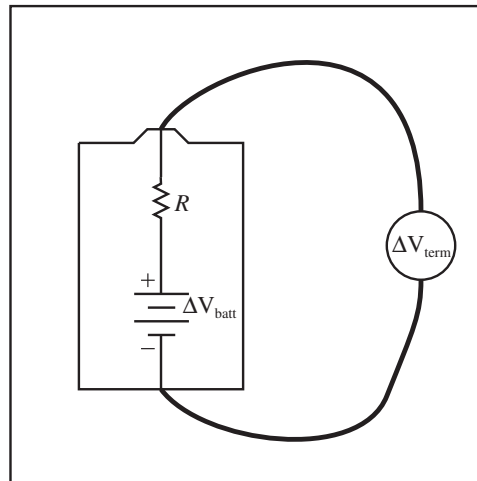

If no current is drawn from the battery, the voltage across the battery is equal the that of the perfect battery, $\Delta V_{batt} = \Delta V_{term}$. A perfect voltmeter draws no current, so connecting a voltmeter across a battery measures ΔV_{batt} . This does not give you an idea of how what the terminal voltage will be at the operating current. As current is drawn from the battery, pumped through the battery, the terminal voltage decreases, $\Delta V_{term} = \Delta V_{batt} - Ir$. Once the terminal voltage drops to zero, you are drawing the maximum current the battery can provide.

21.2 Resistor Networks

Thévenin's theorem states that any network of resistors and voltage sources between two terminals is equivalent to a single resistor and single voltage source. In this section we will investigate a network of resistors only; that is, multiple resistors, but only one voltage source. Although there are techniques for analyzing fairly complex resistor networks, we will investigate only those that are some combination of series and parallel resistors.

21.2.1 Identifying Series and Parallel Combinations of Resistors

The first skill in analyzing a complex circuit containing more than one resistor it to identify which sets of resistors are simple series or parallel combinations.

Definition of Series Combination of Resistors:

Two resistors are in series. If one end of one is connected to one end of the other, in all cases, the same current will flow through each. The resistors at the right are in series.

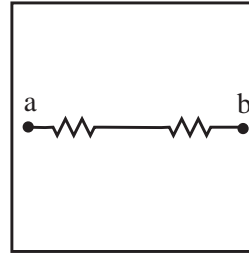
**Definition of Parallel Combination of Resistors:**

Two resistors are in parallel if both ends of each are connected together so that both have the same potential difference for all values of current through the circuit. The resistors at the right are in parallel.

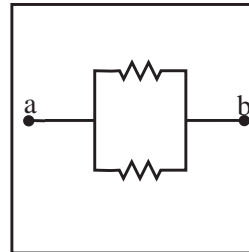
**Example 21.3 Reasoning about Parallel Circuits**

Problem: A $R = 1\Omega$ resistor is in parallel with a $R = 2\Omega$ resistor and connected to a $12V$ battery. Which of the following is the same for both resistors? Power Dissipated, Potential Difference, Current. Justify.

Solution

The potential difference is the same. Since $I = \Delta V/R$ and $P = I\Delta V$, the current and the power dissipated cannot be the same.

Example 21.4 Are Resistors Series/Parallel?

Problem: In the circuit shown at the right, is R_1 in parallel, series, or in no simple relation to R_2 ? How do you know?

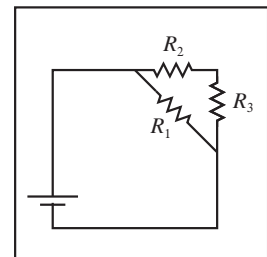

Solution

R_1 has no simple series/parallel relationship to R_2 . R_1 does not carry the same current as R_2 , so they are not in series. R_1 and R_2 are not connected so that each end of each device is at the same potential, so they aren't in parallel.

Example 21.5 Reasoning About Current

Problem: The circuit shown at the right is composed of identical light bulbs. Reason, without calculating, the relation between the currents through B_1 and B_2 .

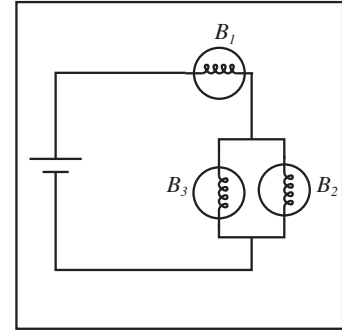

Solution

B_1 is in series with the combination B_2 and B_3 . The current through B_1 is the same as the TOTAL current through B_2 and B_3 . Since the bulbs are identical, half the current flows through each bulb, so B_2 carries half as much current as B_1 .

21.2.2 Reducing Resistor Networks

When a simple series or parallel combination is identified, it can be replaced by an equivalent resistor whose resistance is calculated using the techniques below. This leaves the circuit with fewer resistors and possibly exposes more simple series and parallel combinations. The goal is to reduce the complex circuit to a single resistor, whose resistance is the equivalent resistance of the circuit. With the equivalent resistance, Ohm's law can be used to compute the current drawn by the circuit and the power dissipated.

Definition of Equivalent Resistance: The equivalent resistance of a network of resistors is the resistance of a single resistor which could replace the network and draw the same current with the same potential difference as the network. Since the current and potential difference are the same, the equivalent resistor would also dissipate the same amount of power.

Given resistors R_1 and R_2 connected in series as shown to the right, the sum of the potential differences across each resistor must be the same as the total potential difference across both

$$\Delta V_1 + \Delta V_2 = \Delta V_s$$

The current through each resistor is the same due to conservation of charge

$$I_1 = I_2 = I_s.$$

Since $R_s = \Delta V_s / I_s$, we have a common denominator and

$$R_s = R_1 + R_2$$

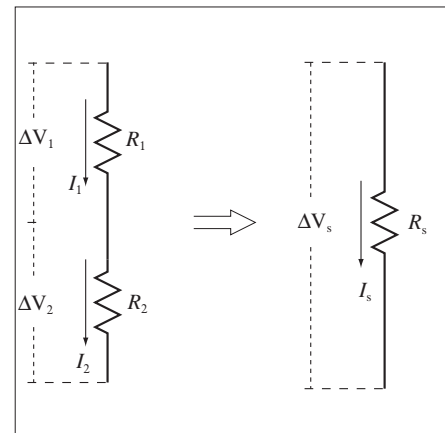

Resistors in Series : Given resistors R_1 and R_2 connected in series the equivalent resistance R_s is

$$R_s = R_1 + R_2$$

Given resistors R_1 and R_2 connected in parallel, the potential difference across each resistor must be the same since the ends are connected by a conductor.

$$\Delta V_1 = \Delta V_2 = \Delta V_p$$

The sum of the currents through each resistor is the same as that coming into the parallel network due to conservation of charge.

$$I_1 + I_2 = I_p.$$

In some sense, a parallel network increases the area through which the current travels, which decreases the resistance. We have $I_p = \Delta V_p / R_p$ which means we have common numerators. To add the currents, we need a common denominator, so we must invert the expression. Thus we can write the equivalent resistance, R_p ,

$$\frac{1}{R_p} = \frac{1}{R_1} + \frac{1}{R_2}$$

Resistors in Parallel : Given resistors R_1 and R_2 connected in parallel, the equivalent resistance, R_p , is

$$\frac{1}{R_p} = \frac{1}{R_1} + \frac{1}{R_2}$$

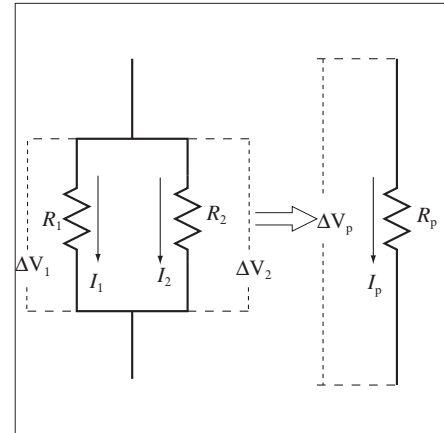

Example 21.6 How to Make Light Bulb Dim

Problem: The circuit to the right is composed of identical light bulbs. What light bulbs, if any, could you unscrew to make B_1 glow brighter?

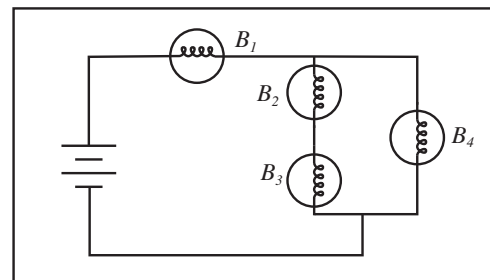

Solution

Unscrewing either B_2 , B_3 , or B_4 will cause B_1 to dim, because the resistance of the combination B_2 , B_3 , B_4 will be increased.

Example 21.7 Current Through More Bulbs

Problem: A light bulb is connected across a battery and glows. Another light bulb is then connected in series with the first bulb and the battery. How does the glow of the first light bulb change? (That is, brighter, dimmer, or no change)? Justify your answer.

Solution

Dimmer. Less current flows through both bulbs because the battery has to push charge through both bulbs in a row. Put another way, the equivalent resistance of the two bulb circuit is higher than the resistance of the single bulb circuit because resistance adds in series. Higher equivalent resistance means lower total current and a dimmer light bulb.

Example 21.8 Reducing a Simple Parallel Combination

Problem: Six 100Ω resistors are connected in parallel and connected across a $6V$ battery.

- (a) What is the equivalent resistance of the six resistors?
 (b) What is the current through ONE of the resistors?
 (c) What is the total power dissipated by the circuit?

Solution to Part(a)

When many resistors with the same resistance are in parallel, the equivalent resistance is the resistance of one divided by the number of resistors, using the equivalent resistance of a parallel combination

$$\frac{1}{R_{eq}} = \frac{1}{R} + \frac{1}{R} + \frac{1}{R} + \frac{1}{R} + \frac{1}{R} + \frac{1}{R} = \frac{6}{R}$$

$$R_{eq} = \frac{R}{6} = \frac{100\Omega}{6} = 16.7\Omega$$

Solution to Part(b)

Each resistor has a potential difference of $6V$, so by Ohm's Law $I = \Delta V/R = 6V/100\Omega = 0.06A$.

Solution to Part(c)

The power dissipated is always $P = I\Delta V$, or substituting Ohm's Law,

$$P = \frac{\Delta V}{R_{eq}} \Delta V = \frac{(\Delta V)^2}{R_{eq}} = \frac{(6V)^2}{16.7\Omega} = 2.2W$$

Finally, let's look at a circuit which has both series and parallel combinations of resistors.

Example 21.9 Find the Equivalent Resistance of a Network of Resistors

Problem: Resistors R_1 and R_2 are in parallel. The R_1 - R_2 combination is in parallel with a series combination of R_3 and R_4 . Compute the equivalent resistance of the combination. The values of the resistors are $R_1 = 60\Omega$, $R_2 = 120\Omega$, $R_3 = 10\Omega$, and $R_4 = 10\Omega$.

Solution

Strategy: Working from the smallest elements, use series and parallel equations to replace them with equivalents and keep working outward.

(a) Draw the Circuit: Examine the circuit, finding simple series and parallel combinations of resistors. Use the series and parallel resistor formulas to compute the equivalent resistance for these combinations. In the figure at the right, resistors R_1 and R_2 are in parallel and resistors R_3 and R_4 are in series.

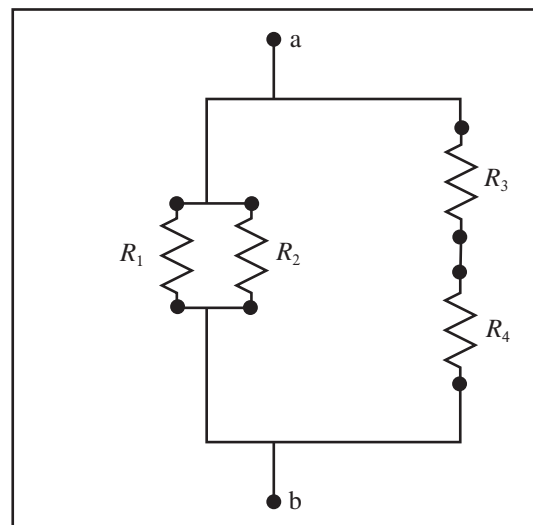

(b) Reduce Series and Parallel Combinations and Redraw:

Working from the individual resistors, reduce parallel and series combinations. Redraw the circuit using equivalents for simple parallel and series combinations. Use the parallel formula on R_1 and R_2 , to compute their equivalent resistance R_p :

$$\frac{1}{R_p} = \frac{1}{R_1} + \frac{1}{R_2} = \frac{1}{60\Omega} + \frac{1}{120\Omega} = \frac{1}{40\Omega}$$

$$R_p = 40\Omega$$

Use the series formula to reduce R_3 and R_4 to their equivalent R_s :

$$R_s = R_3 + R_4 = 10\Omega + 10\Omega = 20\Omega$$

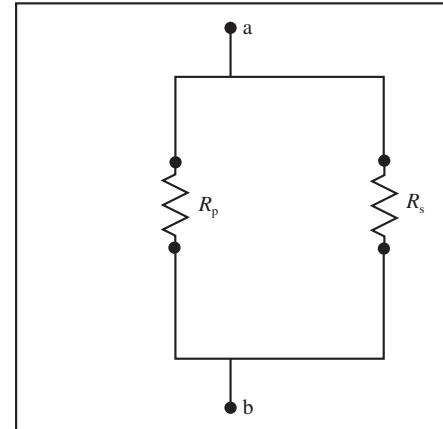

(c) Reduce the Redrawn Circuit: Examine the redrawn circuit for simple series and parallel combinations and continue reduction. Use the parallel formula to reduce the parallel combination R_s and R_p , giving R_{eq} :

$$\frac{1}{R_{eq}} = \frac{1}{R_p} + \frac{1}{R_s} = \frac{1}{40\Omega} + \frac{1}{20\Omega}$$

$$R_{eq} = \frac{40}{3}\Omega$$

Don't get carried away and reduce a part of the circuit which is not a simple combination. Don't do more than one step at a time, or you will make mistakes.

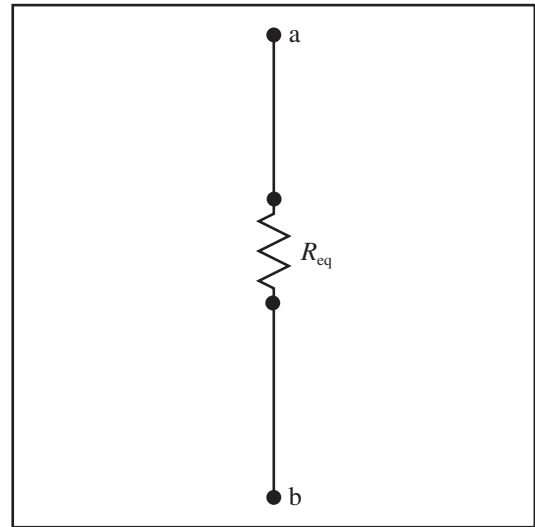
**Example 21.10 Parallel/Series/Parallel Network**

Problem: For the system of resistors to the right, with $\Delta V_0 = 10\text{V}$ and all resistors 100Ω , answer the following,

- What is the equivalent resistance of the network between a and b ?
- What is I_1 ?
- What is I_3 ?
- What is ΔV_5 ?
- How much power does the circuit consume?

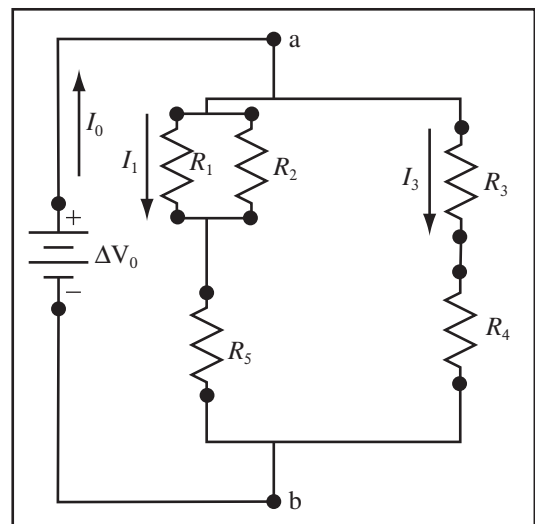

Strategy: Progressively reduce individual series and parallel combinations, and then redraw. Use Ohm's Law and the power dissipated by an Ohmic device to compute the properties of the individual elements.

Solution to Part (a)

(a) First Reduce Parallel Combination: Resistors R_1 and R_2 are in parallel. Replace them with their equivalent resistance R_{12} . In this problem, I_i will be the current through and ΔV_i the voltage across resistor R_i . When a resistor is an equivalent, i will be the numbers of the resistors that went into the equivalent. The value of R_{12} is given by

$$\frac{1}{R_{12}} = \frac{1}{R_1} + \frac{1}{R_2} = \frac{1}{100\Omega} + \frac{1}{100\Omega}$$

$$R_{12} = 50\Omega$$

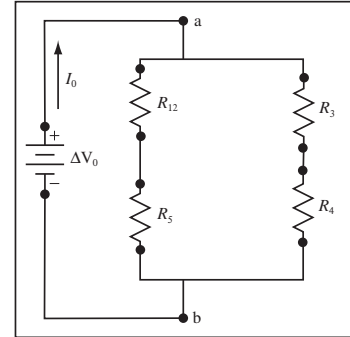

(b) Reduce the Two Series Combinations: Resistors R_{12} and R_5 are in series and resistors add in series, so their equivalent resistance is

$$R_{125} = R_{12} + R_5 = 50\Omega + 100\Omega = 150\Omega.$$

R_3 and R_4 are also in series, so their equivalent resistance, R_{34} is

$$R_{34} = R_3 + R_4 = 100\Omega + 100\Omega = 200\Omega$$

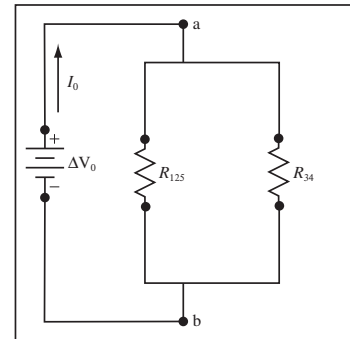

(c) Reduce the Final Parallel Combination: Resistors R_{125} and R_{34} are in parallel and resistors in parallel add, using the formula

$$\frac{1}{R_{eq}} = \frac{1}{R_{125}} + \frac{1}{R_{34}} = \frac{1}{150\Omega} + \frac{1}{200\Omega} = \frac{7}{600\Omega}$$

So the equivalent resistance, R_{eq} , of the circuit is

$$R_{eq} = \frac{600\Omega}{7} = 85.7\Omega$$

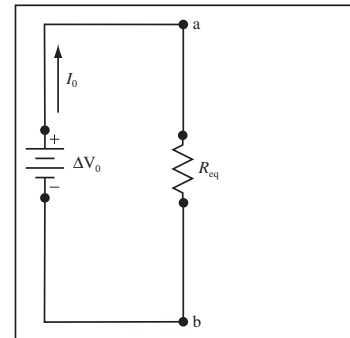

Solution to Part (b)

(a) Compute the Current in the Parallel Branches: Both R_{125} and R_{34} have the full $\Delta V_0 = 10V$ across them, so by Ohm's Law

$$I_{125} = \frac{\Delta V_0}{R_{125}} = \frac{10V}{150\Omega} = 0.067A = I_5 = I_{12}$$

(b) Compute the Voltage Drops in the Series Circuits: Since we have the currents in the series circuits, we can use Ohm's Law to compute the voltage drops,

$$\Delta V_{12} = I_{12}R_{12} = (0.067A)(50\Omega) = 3.3V$$

$$\Delta V_5 = I_5 R_5 = (0.067A)(100\Omega) = 6.7V$$

$$\Delta V_3 = \Delta V_4 = I_3 R_3 = (0.05A)(100\Omega) = 5V$$

(c) Compute the Current Through the R_1 or R_2 : We found the voltage drop across the combination to be $\Delta V_{12} = 3.3V$, now apply Ohm's Law to get the currents, which have to be the same since $R_1 = R_2$.

$$I_1 = \frac{\Delta V_{12}}{R_1} = \frac{3.3V}{100\Omega} = 0.033A = I_2$$

Solution to Part (c)

As computed above

$$I_{34} = \frac{\Delta V_0}{R_{34}} = \frac{10V}{200\Omega} = 0.05A = I_3 = I_4$$

Solution to Part (d)

As computed above,

$$\Delta V_5 = I_5 R_5 = (0.067A)(100\Omega) = 6.7V$$

As is often the case, these circuit reductions have their own pattern of solution which should be followed regardless of the order in which the circuit properties are asked in the problem.

Solution to Part (e)

By Ohm's Law, the total current drawn by the circuit is

$$I_0 = \frac{\Delta V_0}{R_{eq}} = \frac{10V}{85.7\Omega} = 0.12A$$

and the total power consumed by the circuit has to be the same as the total power provided,

$$P_0 = \Delta V_0 I_0 = (10V)(0.12A) = 1.2W$$

21.3 Kirchhoff's Laws

Thus far we have approached the analysis of circuits falling under certain guidelines: multiple resistors in series, parallel, and single constant voltage source (single battery). We have been able to analyze these circuits by reducing the network of resistors to a single equivalent resistance, and then expanding the network back to its original configuration.

We will now set to the task of analyzing circuits with more than one constant voltage source (multiple batteries). The complication that this brings is that sometimes a battery can come "between" resistors in the sense that the simple series or parallel relation no longer holds.

21.3.1 Kirchhoff's Laws

We stated Kirchhoff's laws last chapter, but we called them conservation of charge and independence of path. Kirchhoff's laws allow the calculation of the currents in circuits that are not simple series and parallel combinations. We could get away without the baggage of additional language, but it's traditional. As physicists though, we could just apply physical laws, all we have to do is find convenient points in the circuit to conserve charge and convenient paths around the circuit on which to impose independence of path.

Kirchhoff's Junction Equation: Since charge is conserved and the circuit elements store negligible charge, the current flowing into a junction must equal the current flowing out of the junction

$$\sum I_{in} = \sum I_{out}$$

Kirchhoff's Loop Equation: If there are no significant changing magnetic fields the integral of the electric potential around any closed loop is zero. Therefore, if the wires in a system have negligible resistance (support negligible potential differences), the sum of the potential drops or gains across the devices in a circuit must be zero for any loop:

$$\sum_{loop} \Delta V = 0$$

Later on, we will find that changing magnetic fields are responsible for the spark you sometimes see when unplugging a device.

21.3.2 Navigating Multi-Loop Circuits

The hard part of solving a circuit that cannot be reduced to a single equivalent resistor is finding the currents through EVERY circuit element. The first step in the solution is to figure out what independent currents we need to solve for. To do this we identify the junctions, branches, and loops of a circuit.

Identify Circuit Junctions: The junctions of a circuit are those points at which the current has more than a single path to continue its flow. In the circuit to the right, b and e are junctions since current coming into them can go out by either of two routes.

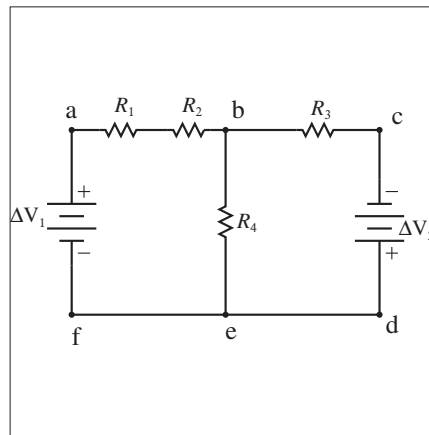

Identify Circuit Branches : Circuit branches are those portions of the circuit that are between junctions. In the circuit to the right, there are three distinct branches (shown in exploded view): b-c-d-e, b-e, and b-a-f-e. In each branch, the direction of current flow needs to be specified. (The direction of current can be a full-out guess ... the mathematics will tell the tale at the problem's end. But once you pick a direction for current, you have to use it consistently.) Since current is conserved, the current through every element of a branch is the same.

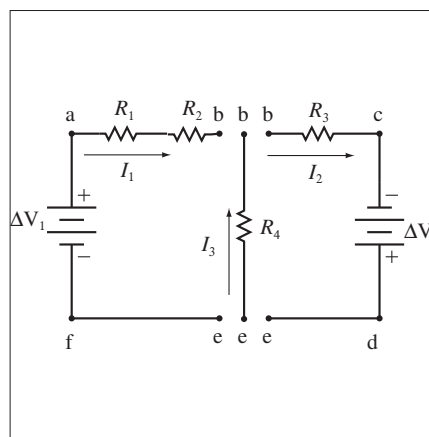

Identify Circuit Loops : A circuit loop is the path from a point in a circuit back to itself. In the circuit to the right, there are three loops (shown in separated views): b-c-d-e-b, b-a-f-e-b, and b-c-d-e-f-a-b. Take note that there are only *two independent* loops for this circuit. (Choosing the direction of the loop is completely arbitrary.)

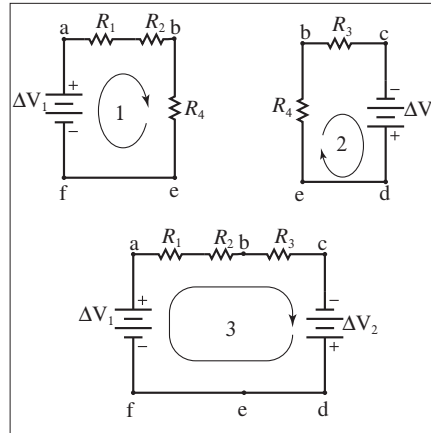

21.3.3 Analyzing Kirchhoff's Law Problems

Let's continue to work with the system above, with the loop and current choices made earlier. The simple series combination R_1 and R_2 has been replaced by its series equivalent, R_s . The sum of the potential differences around loop 1 is

$$\Delta V_{fa} + \Delta V_{ab} + \Delta V_{be} + \Delta V_{ef} = 0$$

Likewise the sum of the potential differences around loop 2 is

$$\Delta V_{eb} + \Delta V_{bc} + \Delta V_{cd} + \Delta V_{de} = 0$$

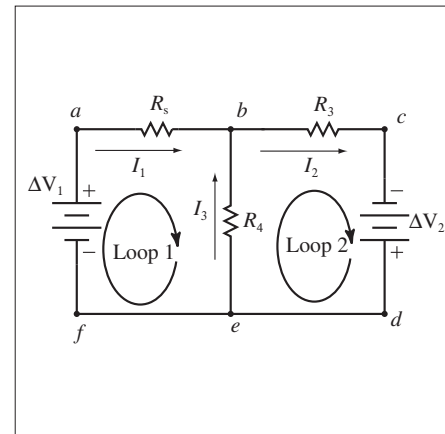

We can reason about the sign of these potential differences physically. We already know the magnitudes. The magnitude of the potential difference across a battery is the battery voltage. The magnitude of the potential difference across a resistor is given by Ohm's law, IR . Batteries are easy, if the potential difference goes from negative to positive, it is positive. If this is reversed, it is negative. For resistors, we know that the current loses energy as it goes through the resistor, so the potential goes down in the direction the current flows.

	Potential Difference	Value	Rise/Drop	Explanation
$f \Rightarrow a$	ΔV_{fa}	$+\Delta V_1$	Rise	The potential difference is from negative to positive across a battery, and is therefore positive.
$a \Rightarrow b$	ΔV_{ab}	$-I_1 R_s$	Drop	The potential goes down as current goes through a resistor.
$b \Rightarrow e$	ΔV_{be}	$+I_3 R_4$	Rise	The potential goes down as current goes through a resistor, therefore the potential at the upstream side of a resistor is higher than the potential at the downstream side.
$e \Rightarrow f$	ΔV_{ef}	0		The potential difference across a conductor is zero.
$b \Rightarrow c$	ΔV_{bc}	$-I_2 R_3$	Drop	The potential difference goes down as current goes through a resistor.
$c \Rightarrow d$	ΔV_{cd}	$+\Delta V_2$	Rise	The potential difference is from negative to positive across a battery, and is therefore positive.
$d \Rightarrow e$	ΔV_{de}	0		The potential difference across a conductor is zero.
$e \Rightarrow b$	ΔV_{eb}	$-I_3 R_4$	Drop	The potential difference goes down as current goes through a resistor.

With these observations, we can make a table of sign conventions for the sign of the potential differences.

Sign Convention for Potential Changes in a Kirchhoff Loop: When applying Kirchhoff's Loop rule, there is a distinction between a potential drop and a potential increase(rise). When traversing the loop in the direction chosen for the loop, the sign of the potential change will either be negative (a potential drop) or positive (a potential increase) according to the following conventions:

Through battery from negative terminal to positive terminal

Add $+\Delta V_{battery}$ to the loop equation, potential increase.

Through battery from positive terminal to negative terminal

Add $-\Delta V_{battery}$ to the loop equation, potential drop.

Through resistor in the direction of the stated current

Add $-IR$ to the loop equation, potential drop.

Through resistor in the opposite direction of the stated current

Add $+IR$ to the loop equation, potential increase.

First, an example where a shortcut simplifies the math.

Example 21.11 Multi-loop Resistor Problem

Problem: Consider the circuit to the right with $\Delta V_1 = 18\text{V}$ and $\Delta V_2 = 6\text{V}$. All resistors are 5Ω . Use the currents I_i and loops that are drawn.

- Write the junction equation for junction j .
- Write the loop equation for Loop 1.
- Write the loop equation for Loop 2.
- Compute I_1 , I_2 , and I_3 .
- What is the total power lost through the resistors in the circuit?
- How much power is provided to the circuit by the batteries in the circuit?

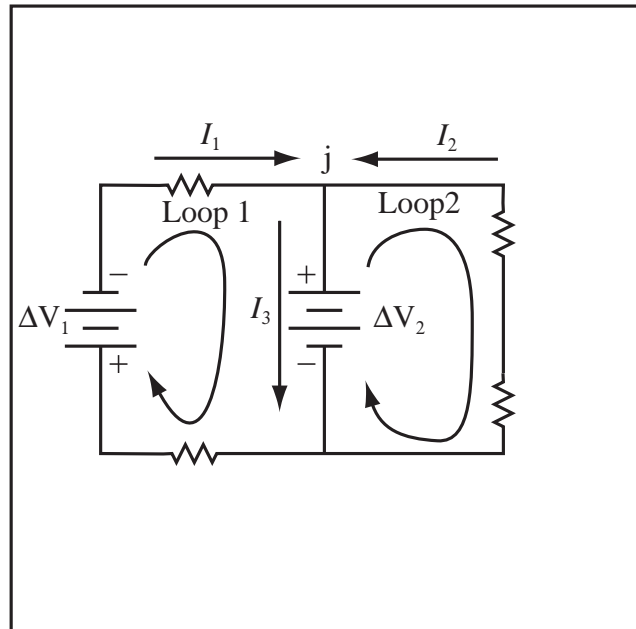

Solution to Part (a)

Because of conservation of charge and the because surface junctions store minimal charge the current into a junction is equal to the current out of a junction, so

$$I_1 + I_2 = I_3$$

Solution to Part (b)

(a) Label Circuit Nodes: Label the nodes in the circuit. It is not necessary to reduce the simple series combination from d to e , Kirchhoff's laws will take care of it for us. I have drawn the direction of the currents at the resistors to help write the potential rise and drop.

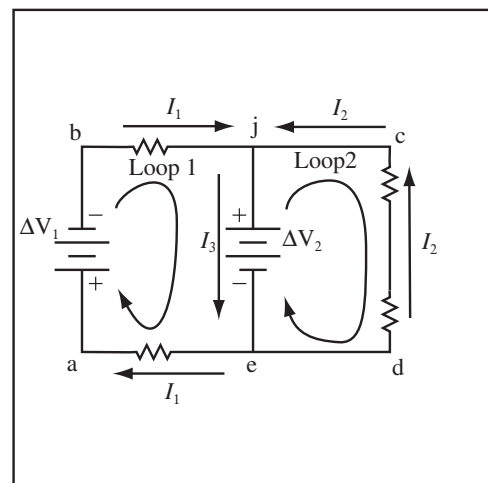

(b) Write Loop Equation 1: The potential difference around any closed path is zero, so

$$\Delta V_{ab} + \Delta V_{bj} + \Delta V_{je} + \Delta V_{ea} = 0$$

To move from a to b , one must move from the $+$ to $-$ end of battery 1, so $\Delta V_{ab} = -\Delta V_1$. To move from b to j , we move through a resistor in the direction of current, so the potential decreases, $\Delta V_{bj} = -I_1 R$. To move from j to e , one must move from the $+$ to $-$ end of battery 2, so $\Delta V_{je} = -\Delta V_2$. Finally, to move from e to a ,

we move through a resistor in the direction of current, so the potential decreases, $\Delta V_{ea} = -I_1 R$. Substitute to produce the first loop equation,

$$\begin{aligned} -\Delta V_1 - I_1 R - \Delta V_2 - I_1 R &= 0 \\ \Delta V_1 + \Delta V_2 + 2I_1 R &= 0 \quad \text{Loop 1} \end{aligned}$$

Solution to Part (c)

The potential difference around loop 2 is also zero, so

$$\Delta V_{ej} + \Delta V_{jc} + \Delta V_{cd} + \Delta V_{de} = 0$$

To move from e to j , one must move from the $-$ to $+$ end of battery 2 increasing the potential, so $\Delta V_{ej} = +\Delta V_2$. To move from j to c , we move through a wire, $\Delta V_{jc} = 0$. To move from c to d , one must move through two resistors opposite the direction of current, so potential increases in each resistor, therefore $\Delta V_{cd} = +I_2 R + I_2 R$. To move from d to e , we again move through a wire so the potential does not change, $\Delta V_{de} = 0$. Substitute to produce the second loop equation,

$$\begin{aligned} \Delta V_2 + 0 + 2I_2 R + 0 &= 0 \\ \Delta V_2 + 2I_2 R &= 0 \quad \text{Loop 2} \end{aligned}$$

Solution to Part (d)

(a) Look for Simplifications: Before punching the three equations with three unknowns into your calculator, see if there are simplifications. In this problem, loop 1 only depends on current 1 and loop 2 only depends on current 2.

(b) Solve for I_1 : Solve loop equation 1 for I_1 ,

$$I_1 = -\frac{\Delta V_1 + \Delta V_2}{2R} = -\frac{18\text{V} + 6\text{V}}{2(5\Omega)} = -2.4\text{A}$$

(c) Solve for I_2 : Solve loop equation 2 for I_2 ,

$$I_2 = -\frac{\Delta V_2}{2R} = -\frac{6\text{V}}{2(5\Omega)} = -0.6\text{A}$$

(d) Solve for I_3 : Solve the junction equation for I_3 ,

$$I_3 = I_1 + I_2 = (-2.4\text{A}) + (-0.6\text{A}) = -3.0\text{A}$$

Solution to Part (e)

The power dissipated by a resistor is $P = I\Delta V = I^2 R$. There are four resistors in the circuit, add the power up,

$$\begin{aligned} P_{lost} &= I_1^2 R + I_1^2 R + I_2^2 R + I_2^2 R \\ P_{lost} &= (-2.4\text{A})^2(5\Omega) + (-2.4\text{A})^2(5\Omega) + (-0.6\text{A})^2(5\Omega) + (-0.6\text{A})^2(5\Omega) \\ P_{lost} &= 61.2\text{W} \end{aligned}$$

Solution to Part (f)

We have to be careful as we calculate the power provided by the batteries. If current flows from $-$ to $+$, the battery provides $I\Delta V$ power. If current flows from $+$ to $-$, the battery is charged by the circuit and removes $I\Delta V$ power from the circuit. For the current directions drawn on the figure, both batteries would be charged by positive current, so

$$P_{batt} = -I_1 \Delta V_1 - I_3 \Delta V_3 = -(-2.4\text{A})(18\text{V}) - (-3\text{A})(6\text{V}) = 61.2\text{W}$$

Energy is conserved and our calculation checks.

Then, an example where no simplification is possible.

Example 21.12 Determining Network Properties of a Circuit Using Kirchhoff's Laws

Problem: Consider the circuit at the right with the following values for the circuit elements: $R_1 = 2.0\Omega$, $R_2 = 4.0\Omega$, $R_3 = 3.0\Omega$, $R_4 = 8.0\Omega$, $\Delta V_1 = 6.0V$, and $\Delta V_2 = 9.0V$. Determine the current through each resistor, the potential difference across each resistor, and the power dissipated or delivered by each circuit element.

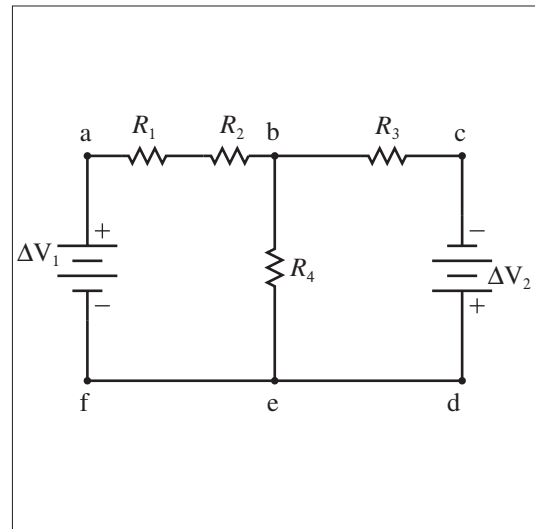

Solution

Definitions

- $R_1 = 2.0\Omega \equiv$ Resistance of Resistor 1
- $R_2 = 4.0\Omega \equiv$ Resistance of Resistor 2
- $R_3 = 3.0\Omega \equiv$ Resistance of Resistor 3
- $R_4 = 8.0\Omega \equiv$ Resistance of Resistor 4
- $V_1 = 6.0V \equiv$ Potential difference of Battery 1
- $V_2 = 9.0V \equiv$ Potential difference of Battery 2
- $R_s \equiv$ Resistance of Series Combination
- $I_i \equiv$ Current through resistor i
- $V_i \equiv$ Voltage Drop across Resistor i
- $P_{R_i} \equiv$ Power Dissipated in Resistor i

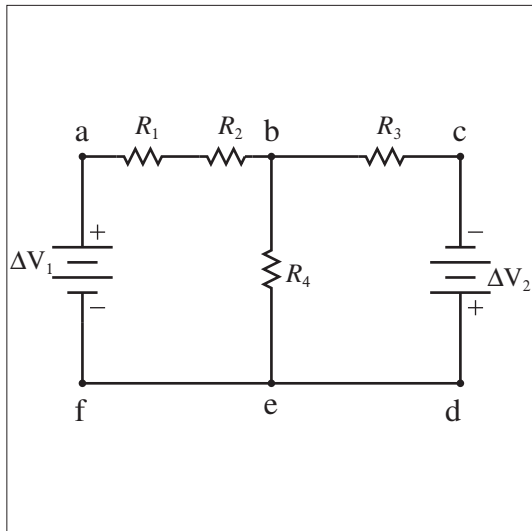

Strategy: Use Kirchhoff's Loop and Junction Equations to produce a sufficient set of independent equations to find the currents.

Section 1 - Draw the Circuit Draw the circuit to be reduced as given (shown above).

Section 2 - Reduce any Simple Series/Parallel Combinations

(a) If there are simple parallel or series combinations of resistors, reduce them. R_1 and R_2 form a series combination:

$$R_s = R_1 + R_2 = 6.0\Omega$$

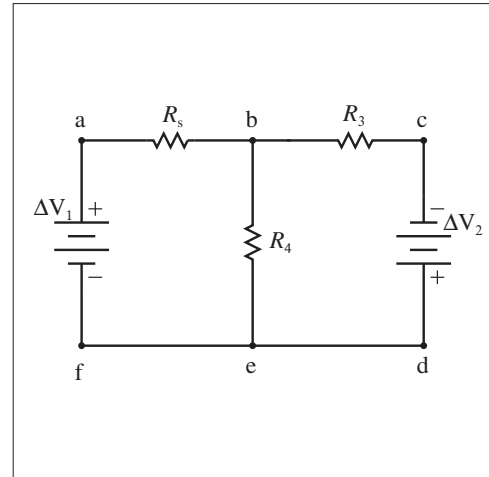

Section 3 - Assign Currents

(a) Assign a current, I_i , to each branch of the circuit. Draw a labelled arrow on the diagram for each current. Be careful not to introduce currents that are redundant, they complicate the math. The direction for each of the currents is a guess; if any of the numerical values for current turn out to be negative, then we know that the direction represented here is opposite to the actual current direction. There are three branches, each with a (possibly) unique current, I_1 , I_2 , and I_3 .

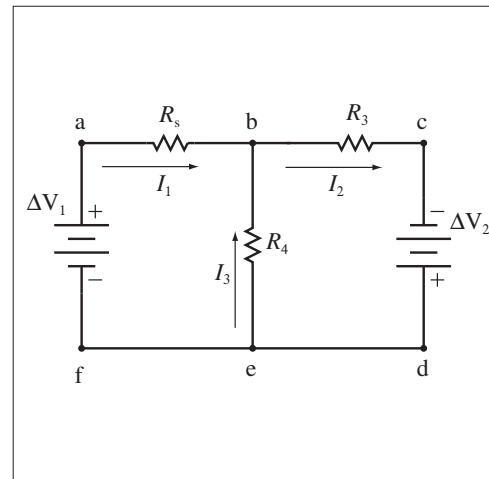

Section 4 - Write Junction Equation

(a) A junction is any place in the circuit where more than two wires are connected. Write a junction equation for each junction until you have a junction equation containing each current. Both junctions, b and e , give the same junction equations using $\sum I_{in} = \sum I_{out}$. Using junction b , the junction equation is

$$I_1 + I_3 = I_2$$

Section 5 - Draw Loops

(a) Draw circuit loops on the drawing. A loop is a path that returns to its starting point. Draw enough loops so that a loop goes through each circuit element. Two loops are sufficient to go through each circuit element. Loop 1 is $a - b - e - f - a$ while Loop 2 is $d - e - b - c - d$.

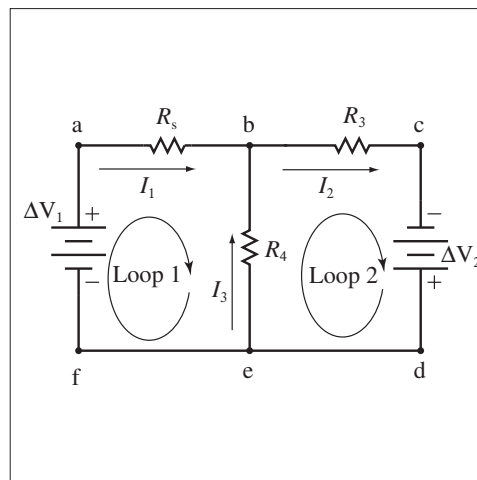

Section 6 - Write Loop Equations For each loop, write a loop equation. Make sure each circuit element appears in at least one loop equation. Furthermore, recall the sign convention for potential differences. Kirchhoff's Rule for circuit loops is $\sum_{loop} \Delta V = 0$.

(a) **Write Loop Equation 1:** The sum of the potential differences for loop 1 is

$$\Delta V_{fa} + \Delta V_{ab} + \Delta V_{be} + \Delta V_{ef} = 0$$

From f to a , the loop goes through the battery from $-$ to $+$, so the potential increases $\Delta V_{fa} = +\Delta V_1$. From a to b , the current goes through a resistor in the same direction as the loop causing a potential drop, $\Delta V_{ab} = -I_1 R_s$. From b to e , the loop goes through the resistor in the opposite direction as the loop, causing a potential rise, $\Delta V_{be} = +I_3 R_4$. From f to e , there is no circuit element. The potential difference across a perfect wire is zero, $\Delta V_{ef} = 0$. The loop equation for Loop 1 is

$$\Delta V_1 - I_1 R_s + I_3 R_4 = 0$$

(b) **Write Loop Equation 2:** The sum of the potential differences for loop 2 is

$$\Delta V_{eb} + \Delta V_{bc} + \Delta V_{cd} + \Delta V_{de} = 0$$

From e to b , the loop goes through a resistor in the same direction as the current, so the potential decreases (drops) $\Delta V_{eb} = -I_3 R_4$. From b to c , the current goes through a resistor in the same direction as the loop, causing a potential drop, $\Delta V_{bc} = -I_2 R_3$. From c to d , the loop goes through a battery from negative to positive causing a potential rise, $\Delta V_{cd} = +\Delta V_2$. From d to e , there is no circuit element. The potential difference across a perfect wire is zero, $\Delta V_{de} = 0$.

The loop equation for Loop 2 is

$$-I_3 R_4 - I_2 R_3 + \Delta V_2 = 0$$

Section 7 - Solve the Complete Set of Equations Use mathematical techniques to solve for the unknown currents. We have three unknown currents and three equations, so we're in business.

(a) **System of Equations to be Solved:** Solve the three independent equations:

$$I_1 + I_3 = I_2 \quad (1)$$

$$-I_1 R_s + I_3 R_4 + \Delta V_1 = 0 \quad (2)$$

$$-I_3 R_4 - I_2 R_3 + \Delta V_2 = 0 \quad (3)$$

(b) **Eliminate I_2 :** Substitute (1) into (3) to eliminate I_2 giving (4):

$$-I_3 R_4 - (I_1 + I_3) R_3 + \Delta V_2 = 0 \quad (4)$$

Group in terms of current:

$$-I_1 R_3 - (R_3 + R_4) I_3 + \Delta V_2 = 0 \quad (4')$$

(c) **Solve for I_1 :** Solve (2) for I_1 in terms of I_3 to give (5):

$$I_1 = \frac{I_3 R_4 + \Delta V_1}{R_s} \quad (5)$$

(d) **Substitute:** Substitute (5) into (4) giving (6):

$$-\left(\frac{I_3 R_4 + \Delta V_1}{R_s}\right)R_3 - (R_3 + R_4)I_3 + \Delta V_2 = 0 \quad (6)$$

(e) **Solve for I_3 :** Solve (6) for I_3 :

$$I_3 = \frac{\Delta V_2 - \frac{\Delta V_1 R_3}{R_s}}{\frac{R_3 R_4}{R_s} + R_3 + R_4} = \frac{9V - \frac{(6V)(3\Omega)}{6\Omega}}{\frac{(8\Omega)(3\Omega)}{(6\Omega)} + 3\Omega + 8\Omega}$$

$$I_3 = \frac{2}{5} \text{ A}$$

(f) **Solve for I_1 :** Solve (2) for I_1

$$I_1 = \frac{I_3 R_4 + \Delta V_1}{R_s}$$

$$= \frac{(\frac{2}{5} \text{ A})(8\Omega) + 6V}{6\Omega} = \frac{16V + 30V}{30\Omega}$$

$$I_1 = \frac{23}{15} \text{ A}$$

(g) **Solve for I_2 :** Use (1) to compute I_2 :

$$I_2 = I_1 + I_3 = \frac{2}{5} \text{ A} + \frac{23}{15} \text{ A}$$

$$I_2 = \frac{29}{15} \text{ A}$$

Section 8 - Calculate Potential Differences Across Resistors

(a) Use Ohm's Law, $V = IR$, to calculate the potential difference across each resistor.

Using Ohm's Law:

$$\Delta V_{R_3} = I_2 R_3 = \frac{29}{5} \text{ V}$$

$$\Delta V_{R_4} = I_3 R_4 = \frac{16}{5} \text{ V}$$

$$\Delta V_{R_s} = I_1 R_s = \frac{46}{5} \text{ V}$$

The potential difference across R_s is actually the potential difference across two resistors, R_1 and R_2 . Since they are in series, we know that the current is the same through both, I_1 . Use Ohm's Law for these two resistors to obtain

$$\Delta V_{R_1} = I_1 R_1 = \frac{46}{15} \text{ V}$$

$$\Delta V_{R_2} = I_1 R_2 = \frac{92}{15} \text{ V}$$

Section 9 - Check for Consistency

(a) Check that the junction equation and the loop equations work with the numeric answers. I often make mistakes in Kirchhoff's Law problems, checking the loops allows me to find the errors and fix them.

symbolic equation	numerical equation	checks?
$I_1 + I_3 = I_2$	$\frac{23}{15} + \frac{2}{5} = \frac{29}{15}$	yes
$-I_1 R_s + I_3 R_4 + \Delta V_1 = 0$	$-\frac{23}{15} \cdot 6.0 + \frac{2}{5} \cdot 8.0 + 6.0 = 0$	yes
$-I_3 R_4 - I_2 R_3 + \Delta V_2 = 0$	$-\frac{2}{5} \cdot 8.0 - \frac{29}{15} \cdot 3.0 + 9.0 = 0$	yes

Section 10 - Compute Power Dissipated

(a) Use the power law for Ohmic devices, $P = IV$, to calculate the power lost by each resistor.

$$P_1 = I_1 \Delta V_1 = \left(\frac{23}{15} \text{ A} \right) \left(\frac{46}{15} \text{ V} \right) = 4.7 \text{ W}$$

$$P_2 = I_1 \Delta V_2 = \left(\frac{23}{15} \text{ A} \right) \left(\frac{92}{15} \text{ V} \right) = 9.4 \text{ W}$$

$$P_3 = I_2 \Delta V_3 = \left(\frac{29}{15} \text{ A} \right) \left(\frac{29}{5} \text{ V} \right) = 11 \text{ W}$$

$$P_4 = I_3 \Delta V_4 = \left(\frac{2}{5} \text{ A} \right) \left(\frac{16}{5} \text{ V} \right) = 1.3 \text{ W}$$

Chapter 22

Capacitive Circuits

In this chapter, we learn to work with capacitors in electric circuits.

22.1 Capacitor Networks

22.1.1 Combining Capacitors

In the first two chapters, we used capacity or the size of the conductor to reason about how charge is shared between two conductors in contact. Electrical connection between conducting spheres is the same as electrical connection in circuits; an electrical connection makes the potential difference between the two connected objects zero, because the potential difference across a conductor is zero. We now have enough physics to formally analyze circuits containing capacitors.

Circuit Symbols for Capacitor: The symbol for a capacitor in an electric circuit is shown to the right.

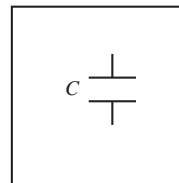

Let's consider two parallel plate capacitors as shown below. There are two ways to make a connection to the battery; the series and the parallel circuit.

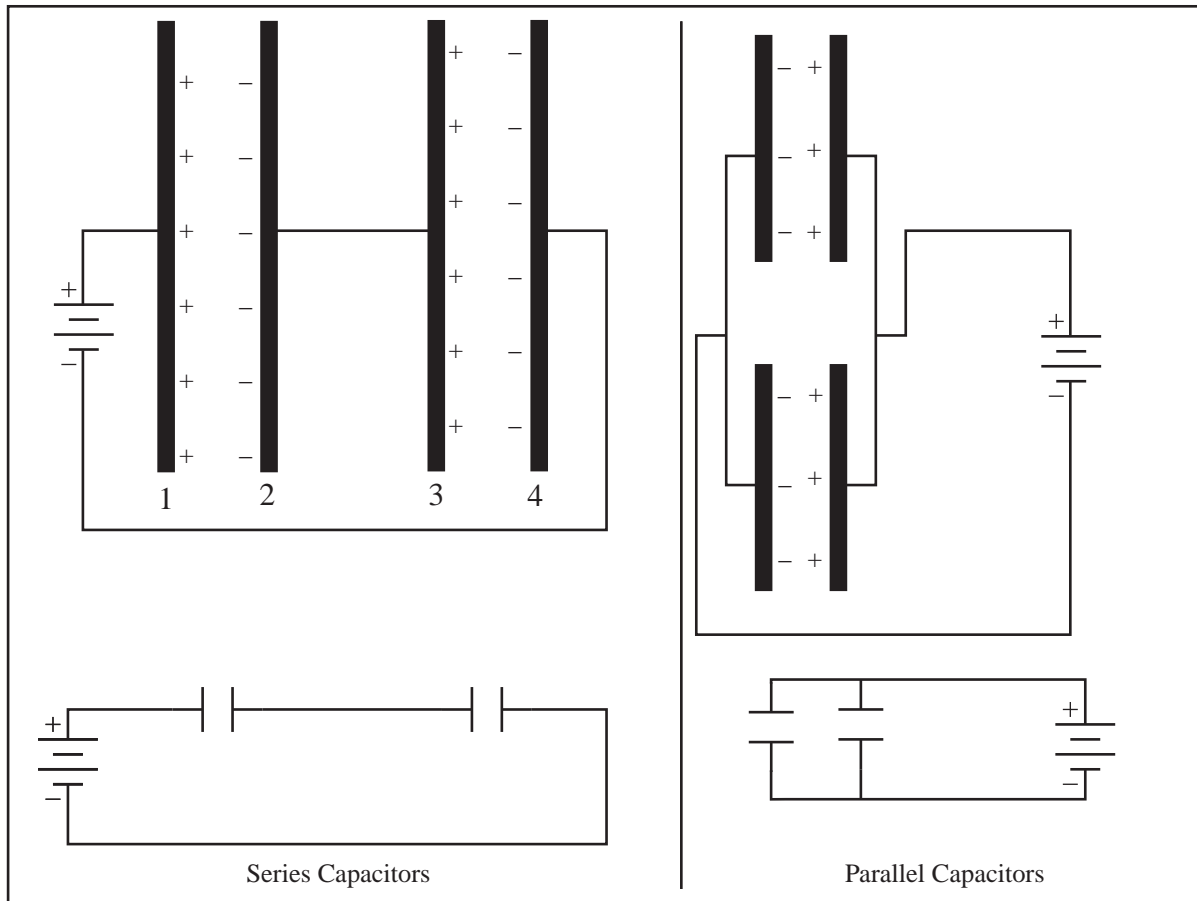

For two identical parallel capacitors, the two-capacitor system simply increases the plate area by a factor of two (imagine sliding the capacitors together). For parallel plate capacitors, the capacitance is $C = \epsilon_0 A/d$, so doubling the plate area doubles the capacitance. In general, for a parallel combination $C_{parallel} = C_1 + C_2$; the capacitance adds.

In the series combination of two identical capacitors, we have halved the potential difference, since half the potential difference of the battery is established across each capacitor. In general for a series combination, $1/C_{series} = 1/C_1 + 1/C_2$. This expression is derived in the next section.

In the series combination, where does the charge on plates 2 and 3 come from? Charge cannot be moved from plate 1 to plate 2 or from plate 3 to plate 4 because the airspace between the plates is an insulator. The negative charge on plate 2 must be taken from plate 3 leaving a positive charge on plate 3.

What about two of our isolated spherical capacitors connected together? For example, two of the 12cm globes we use with the Van de Graaff are connected by a wire. The capacitance of each isolated globe is computed with respect to the ground. All grounds may be assumed to be connected. If the globes were connected to a battery, the circuit to the right would result. If we imagine connecting the grounds, the isolated spheres are in parallel and their capacitance adds.

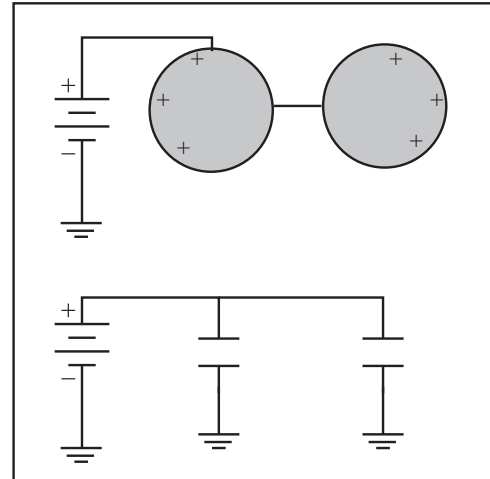

22.1.2 Reducing Capacitive Circuits

Reducing a capacitive circuit involves taking a combination of capacitors and figuring out what capacitor they could be replaced with and still behave the same.

Definition of Equivalent Capacitance: If a potential difference ΔV is applied to an arbitrarily complicated system of conductors, a charge Q will be transferred through the source of potential difference to the capacitors. This is the same electrical behavior of a single “equivalent” capacitor with capacitance $C_{eq} = Q/\Delta V$. The equivalent capacitance is the capacitance of a single capacitor that could replace a network of capacitors and yield the same electrical properties.

The strategy is to locate series and parallel combinations in the circuit and replace them with their equivalent capacitors using the formulas which follow; redraw the circuit, and keep doing it until only one capacitor is left. The capacitance of the capacitor is the equivalent capacitance of the circuit.

Capacitors C_1 and C_2 are connected in parallel (as in the figure to the right). In effect, the area of the capacitor plates has been increased which increases the capacitance. The potential drop across each capacitor is the same (definition of parallel)

$$\Delta V_1 = \Delta V_2 = \Delta V_R.$$

where ΔV_R is the voltage applied across the equivalent capacitance. The total charge is shared between the capacitors

$$Q_1 + Q_2 = Q_R.$$

Since $C_R = Q_R/\Delta V_R$ and we have a common denominator, we can simply write the equivalent capacitance, C_R ,

$$C_R = C_1 + C_2,$$

which is larger than either of the capacitors alone.

Capacitors in Parallel: The equivalent capacitance of two capacitors C_1 and C_2 connected in parallel is

$$C_R = C_1 + C_2,$$

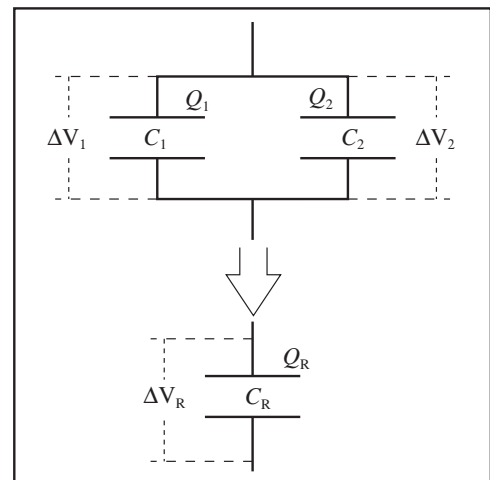

Now, we need to handle the series case. Capacitors C_1 and C_2 are connected in series (as in the figure to the right). The sum of the potential drops across each capacitor must be the same as the total drop across both

$$\Delta V_1 + \Delta V_2 = \Delta V_R.$$

The potential drop across each capacitor can be found from the definition of capacitance.

$$\Delta V_1 = \frac{Q_1}{C_1} \quad \Delta V_2 = \frac{Q_2}{C_2} \quad \Delta V_R = \frac{Q_R}{C_R}$$

Substituting yields

$$\frac{Q_1}{C_1} + \frac{Q_2}{C_2} = \frac{Q_R}{C_R}$$

The charge on each plate is the same (in magnitude) due to conservation of charge

$$Q_1 = Q_2 = Q_R.$$

Canceling the Q_i s gives the equivalent capacitance, C_R ,

$$\frac{1}{C_R} = \frac{1}{C_1} + \frac{1}{C_2},$$

which is always less than either of the capacitors alone.

Capacitors in Series: The equivalent capacitance of C_1 and C_2 connected in series is

$$\frac{1}{C_R} = \frac{1}{C_1} + \frac{1}{C_2},$$

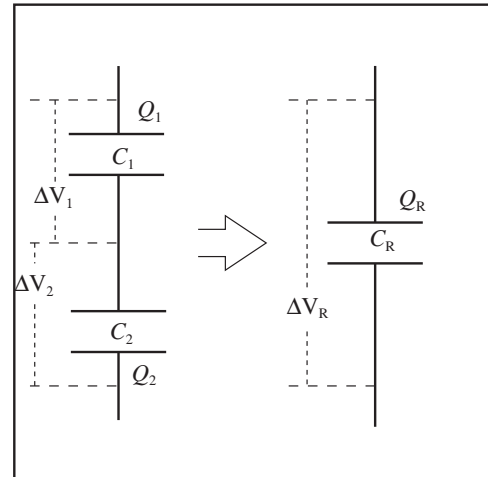

Example 22.1 Find the Equivalent Capacitance and Circuit Properties of a Network of Capacitors

Problem: Three capacitors comprise a network, as shown at the right. Two capacitors, $C_1 = 12\text{nF}$ and $C_2 = 6.0\text{nF}$, are connected in series. These are then connected in parallel with another capacitor, $C_3 = 3.0\text{nF}$, to complete the network of capacitors. A potential difference of $V_a - V_b = 12\text{V}$ is established from a to b . Find the equivalent capacitance, the potential difference, energy, and charge of each capacitor and sub-network.

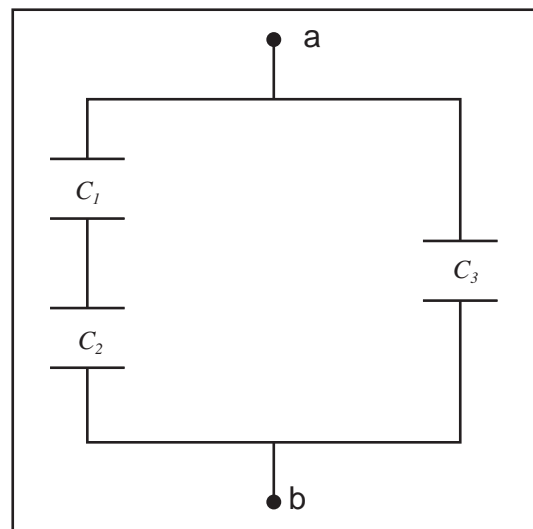

Solution

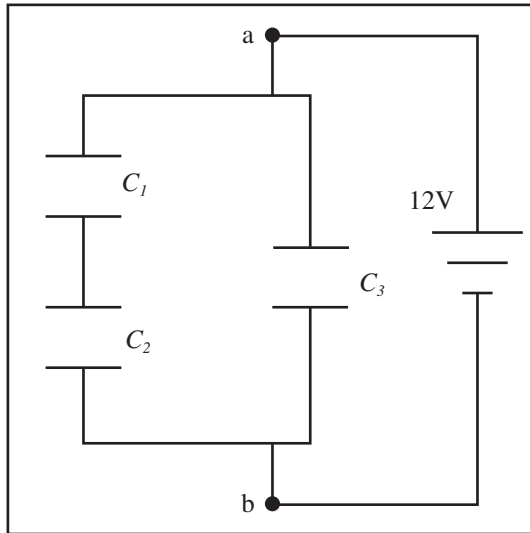

Definitions

- $Q_i \equiv$ Charge on one plate of Capacitor i
- $C_i \equiv$ Capacitance of Capacitor i
- $\Delta V_i \equiv$ Potential Difference across Capacitor i
- $\Delta V_0 = 12V \equiv$ Applied Voltage
- $\Delta V_s \equiv$ Voltage Across Series Combination
- $C_p \equiv$ Equivalent Capacitance
- $C_s \equiv$ Equivalent Series Capacitance
- $U_i \equiv$ Energy Stored in i

Strategy: Working from the smallest elements, use series and parallel equations to replace them with equivalents and keep working outward. Then apply the definition of capacitance to each sub-network to compute the potential difference and charge of each element.

(a) Working from the individual capacitors, reduce parallel and series combinations. Redraw the circuit using equivalents for simple parallel and series combinations. Use the formula for capacitors in series on C_1 and C_2 :

$$\begin{aligned} \frac{1}{C_s} &= \frac{1}{C_1} + \frac{1}{C_2} \\ &= \frac{C_1 + C_2}{C_1 C_2} \\ C_s &= \frac{C_1 C_2}{C_1 + C_2} \\ C_s &= \frac{(12 \times 10^{-9}\text{F})(6.0 \times 10^{-9}\text{F})}{12 \times 10^{-9}\text{F} + 6.0 \times 10^{-9}\text{F}} = 4.0 \times 10^{-9}\text{F} \\ C_s &= 4.0\text{nF} \end{aligned}$$

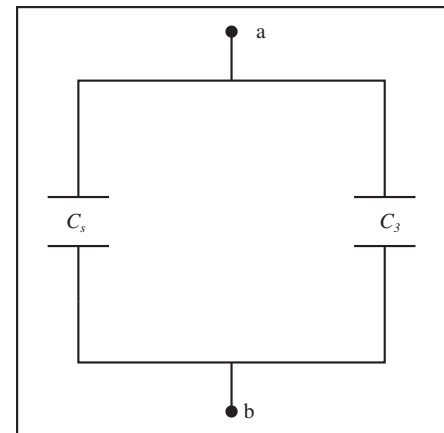

Redraw the circuit.

(b) Examine the redrawn circuit for simple series and parallel combinations and continue reduction. Use parallel capacitor formula on C_s and C_3

$$\begin{aligned} C_p &= C_s + C_3 \\ C_p &= 4.0 \times 10^{-9}\text{F} + 3.0 \times 10^{-9}\text{F} \\ C_p &= 7.0\text{nF} \end{aligned}$$

Don't get carried away and reduce a part of the circuit which is not a simple combination. Don't do more than one step at a time, you will make mistakes.

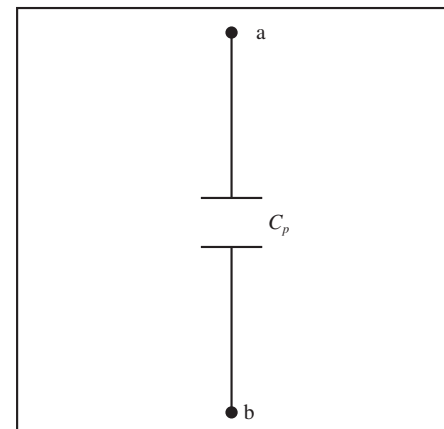

(c) Begin with the equivalent circuit, and apply the definition of capacitance. We know that the potential difference across the equivalent capacitor is $\Delta V_p = \Delta V_0 = 12\text{V}$. The charge on the equivalent capacitor is

$$Q_p = C_p \Delta V_p = (7.0 \times 10^{-9}\text{F})(12\text{V}) = 84 \times 10^{-9}\text{C}$$

$$Q_p = 84\text{nC}$$

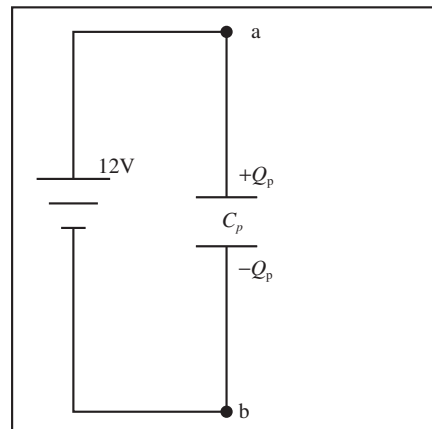

(d) Now the network is the parallel combination of C_s and C_3 . The potential difference across each is the same since they are in parallel, $\Delta V_s = \Delta V_3 = 12\text{V}$. Use definition of capacitance to compute the charge on one plate of C_3 and on the outermost plate of the series combination.

$$Q_s = C_s \Delta V_s = (4.0 \times 10^{-9}\text{F})(12\text{V}) = 48\text{nC}$$

$$Q_3 = C_3 \Delta V_3 = (3.0 \times 10^{-9}\text{F})(12\text{V}) = 36\text{nC}$$

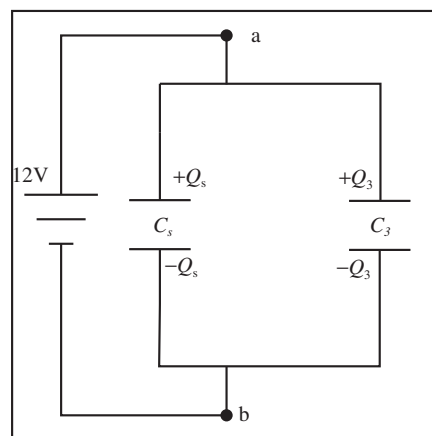

(e) For the series combination of C_1 and C_2 , the charge on each is the same as the equivalent capacitor,

$$Q_1 = Q_2 = Q_s = 48\text{nC}.$$

The potential differences across each can be determined from the definition of capacitance

$$\Delta V_1 = Q_1/C_1 = 48 \times 10^{-9}\text{C}/12 \times 10^{-9}\text{F}$$

$$\Delta V_1 = 4.0\text{V}$$

$$\Delta V_2 = Q_2/C_2 = 48 \times 10^{-9}\text{C}/6.0 \times 10^{-9}\text{F}$$

$$\Delta V_2 = 8.0\text{V}$$

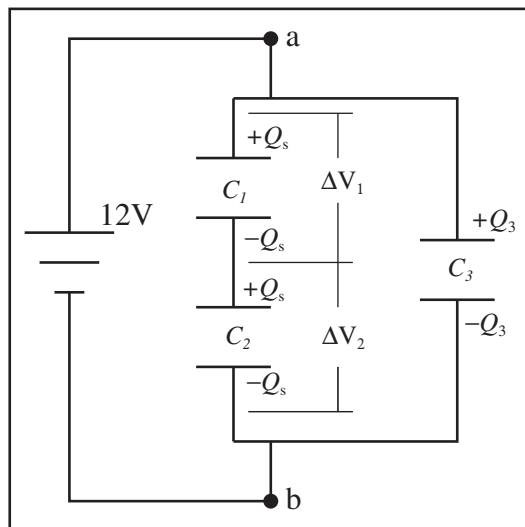

(f) Once the voltage and charge on each capacitor in the network is known we can determine the energy stored in each one. Use the energy stored in a capacitor, $U = \frac{1}{2}Q\Delta V$ to compute the energy in each capacitor,

$$U_1 = \frac{1}{2}Q_1\Delta V_1 = \frac{1}{2}(48 \times 10^{-9}\text{C})(4.0\text{V}) = 96\text{nJ}$$

$$U_2 = \frac{1}{2}Q_2\Delta V_2 = \frac{1}{2}(48 \times 10^{-9}\text{C})(8.0\text{V}) = 192\text{nJ}$$

$$U_3 = \frac{1}{2}Q_3\Delta V_3 = \frac{1}{2}(36 \times 10^{-9}\text{C})(12\text{V}) = 216\text{nJ}$$

Once the equivalent capacitance is found, it can be used to find the total energy stored in a circuit and the total charge delivered by the battery. You can work backward to find the charge and potential difference of each of the individual capacitors.

Example 22.2 Charge Stored in an Equivalent Capacitance

Problem: Two 12pF capacitors are connected in parallel. The combination is in series with a 36pF capacitor and are connected to a 12V battery. How much negative charge does the negative terminal of the battery provide?

Solution

Capacitors add in parallel, so the equivalent capacitance of the parallel combination is $C_{parallel} = 12\text{pF} + 12\text{pF} = 24\text{pF}$. This parallel combination is in series with the 36pF capacitor. Using the series formula for capacitance, the equivalent capacitance of the circuit is

$$\frac{1}{C_{eq}} = \frac{1}{36\text{pF}} + \frac{1}{24\text{pF}} = \frac{5}{72\text{pF}}$$

Therefore the equivalent capacitance is $C_{eq} = 14.4\text{pF}$. By definition of capacitance,

$$Q = C_{eq}\Delta V = (14.4\text{pF})(12\text{V}) = 1.72 \times 10^{-10}\text{C} = 0.2\text{nC}$$

Chapter 23

RC Circuits

23.1 Reasoning About RC Circuits

The next three sections consider circuits involving both capacitors and resistors.

23.1.1 General Behavior of RC Circuits

An RC circuit is a circuit composed of resistors, capacitors, and sometimes batteries. When an RC circuit is initially connected to a battery, current flows, and the capacitors begin to charge. In lecture, I charged a capacitor by connecting it directly across the terminals of a battery. The battery pumped charge from one plate of the capacitor to the other until the potential difference across the capacitor was the same as the potential difference across the battery. Nothing happens instantaneously (except maybe EPR). The battery cannot transfer charge to the capacitor in zero time. Furthermore, as charge starts to build up on the capacitor plates, a potential difference develops between the plates, and it becomes harder to push more charge into the capacitor, so the rate of charging slows. If a resistor were connected in series with the capacitor and battery, a lower current would flow and it would take longer to charge the capacitor. If the capacitor had larger capacitance, it would take more charge to develop the battery potential difference, and therefore longer to charge. The rate of charging or discharging is captured by a characteristic time, called the time constant τ , to complete about 1/3 of the operation.

If an RC circuit starts out with capacitors uncharged and is connected to a battery causing the capacitors to charge, the circuit is said to *charge*. We will call such a circuit a *charging RC circuit*. If only resistors and capacitors are in the circuit and the capacitors start out charged when the circuit is connected and lose their charge by passing current through the resistors, the circuit is said to *discharge*. We will call such a circuit a *discharging RC circuit*.

23.1.2 Short and Long Time Behavior of RC Circuits

Kirchhoff's laws apply to RC circuits (and to any other kind of circuit). To understand an RC circuit, we need to know how the capacitors affect the potential differences and currents in the circuit. At all times, the potential difference across a capacitor is by definition

$$\Delta V_C = \frac{Q}{C}$$

where Q is the charge on one plate of the capacitor and C is the capacitance. The current "through" the capacitor is always

$$I = \pm \frac{dQ}{dt}$$

No current actually goes through the capacitor, since charge cannot pass directly from plate to plate. For a charging capacitor, equal amounts of negative charge flow away from the positive plate and flow to the negative plate, making it appear that current is passing directly through the capacitor. Discharging capacitors are discussed later in the chapter.

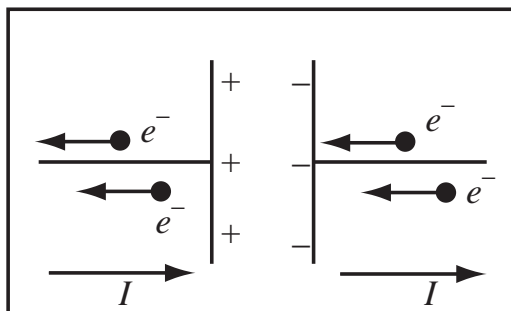

If the capacitor is uncharged, the potential difference across the capacitor is

$$\Delta V_C = \frac{Q}{C} = \frac{0}{C} = 0$$

and it behaves as a wire, an element with no potential difference, in a circuit.

Uncharged Capacitor Behavior: A fully uncharged capacitor has zero potential difference across the capacitor plates.

If a capacitor is fully charged, it can accept no more charge, and zero current passes through it. The capacitor behaves as an open circuit.

Fully Charged Capacitor Behavior: The current through a fully charged capacitor is zero.

Example 23.1 Long and Short Time Behavior of a Charging RC Circuit

Problem: In the circuit to the right, $R_1 = 1000\Omega$, $R_2 = 1000\Omega$, $C_1 = 1000\mu\text{F}$, $C_2 = 2000\mu\text{F}$, and $\Delta V_0 = 10\text{V}$. Initially, all capacitors are uncharged.

- What are the currents and voltage drops across all components immediately after S_1 is closed?
- What are the currents and voltage drops across all components after a long time?

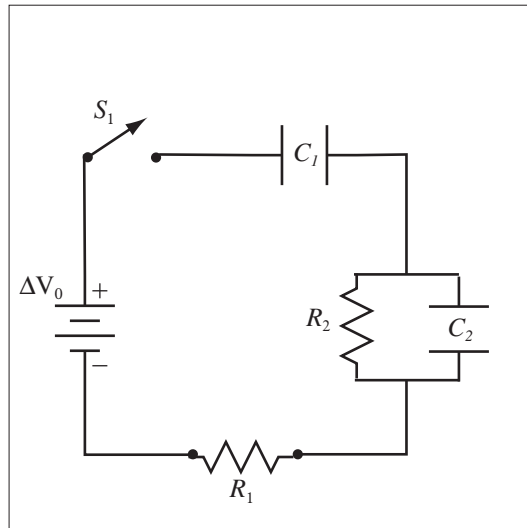

Solution to Part(a)

Immediately after S_1 closes, the capacitors offer no resistance to the flow of current and so the potential difference across the capacitors is zero, therefore $\Delta V_{C_1} = 0$ and $\Delta V_{C_2} = 0$. Because it is in parallel with a capacitor, $\Delta V_{R_2} = 0$. Then by Kirchhoff's Loop Equation, $\Delta V_0 = \Delta V_{R_1} = 10\text{V}$. The currents in the circuit are found by Ohm's Law, $I_1 = \Delta V_1/R_1 = 10\text{mA}$. All this current flows through C_2 because at the time switch S_1 is closed, it presents zero resistance while R_2 has finite resistance, so $I_{R_2} = 0$ and $I_{C_2} = I_1$. This current must also flow through C_1 , so $I_{C_1} = I_1$.

Solution to Part(b)

After a long time, C_1 becomes fully charged and blocks all current; the current in all elements of the circuit becomes zero. By Ohm's Law, if zero current is flowing, $\Delta V_{R_1} = \Delta V_{R_2} = 0$. This implies $\Delta V_{C_2} = 0$. By Kirchhoff's Loop Equation, this means $\Delta V_{C_1} = \Delta V_0 = 10\text{V}$.

Example 23.2 Analyze Long Time Behavior of a Charging RC Circuit

Problem: The RC circuit shown below has circuit elements of the following values: $\Delta V = 12\text{V}$, $R_1 = 3.0\text{M}\Omega$, $R_2 = 6.0\text{M}\Omega$, and $C = 3.0\mu\text{F}$. When answering the following questions, assume that the circuit has been closed for a long time. What is the current through each resistor? What is the potential difference across each resistor? How much charge is stored on each plate of the capacitor?

Solution

Definitions

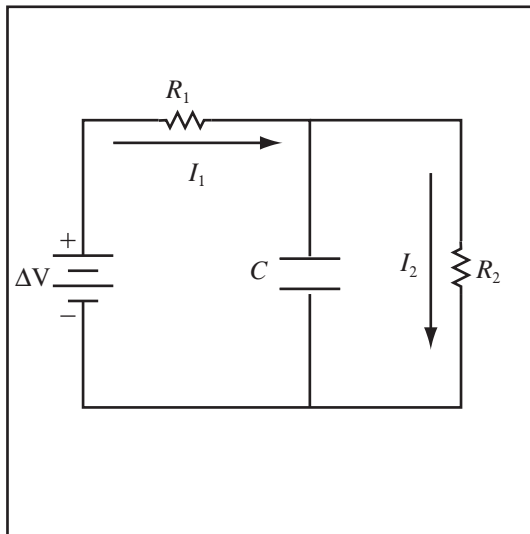

$\Delta V = 12\text{V} \equiv$ Potential difference between battery terminals

$R_1 = 3.0\text{M}\Omega \equiv$ Resistance of first resistor

$R_2 = 6.0\text{M}\Omega \equiv$ Resistance of second resistor

$C = 3.0\mu\text{F} \equiv$ Capacitance of capacitor

$I_1 \equiv$ Current through first resistor

$I_2 \equiv$ Current through second resistor

$\Delta V_1 \equiv$ Potential difference across first resistor

$\Delta V_2 \equiv$ Potential difference across second resistor

$\Delta V_C \equiv$ Potential difference across capacitor

Strategy: Use the fact that at long times, capacitors do not pass any current, analyze the resulting DC Circuit, and use the voltage drops to get the capacitor voltage, and the definition of capacitance to get the charge.

(a) Redraw the circuit leaving connection points for the capacitors, but exclude the capacitors. Since at long times the capacitors draw no current, they do not contribute to the circuit properties. The circuit given in the sample problem is simplified in the long-time limit to be without the capacitor, leaving the two resistors in series with the battery.

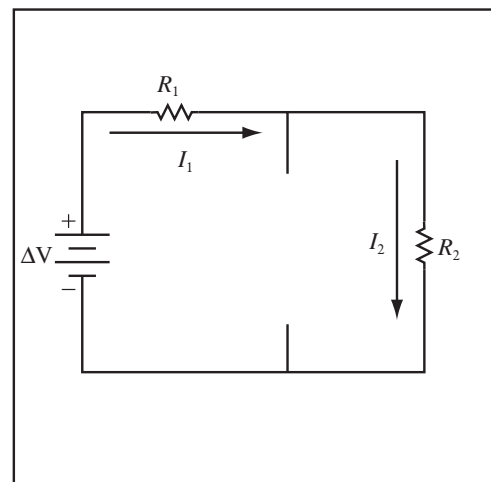

(b) The resulting circuit is a simple DC circuit and the currents can be solved for using techniques for DC circuits. The two resistors in series can be reduced to a single equivalent resistor, $R_s = 9.0\text{M}\Omega$. The potential drop across this resistor is the same as that between the terminals of the battery. Using Ohm's Law we find the current through the equivalent resistor

$$I = \Delta V / R_s = 12\text{V} / (9.0 \times 10^6 \Omega) = \frac{4}{3} \times 10^{-6} \text{A}$$

which is the current through both real resistors since they are in series $I_1 = I_2 = I$.

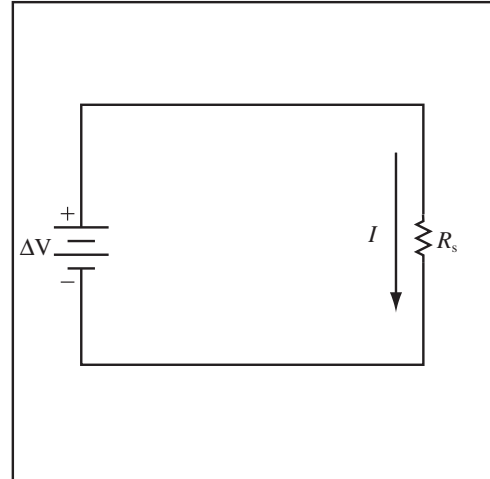

(c) We can use Ohm's Law, $\Delta V = IR$, to find the potential difference across each resistor.

$$\Delta V_1 = I_1 R_1 = \left(\frac{4}{3} \times 10^{-6} \text{A} \right) \cdot (3.0 \times 10^6 \Omega) = 4.0\text{V}$$

$$\Delta V_2 = I_2 R_2 = \left(\frac{4}{3} \times 10^{-6} \text{A} \right) \cdot (6.0 \times 10^6 \Omega) = 8.0\text{V}$$

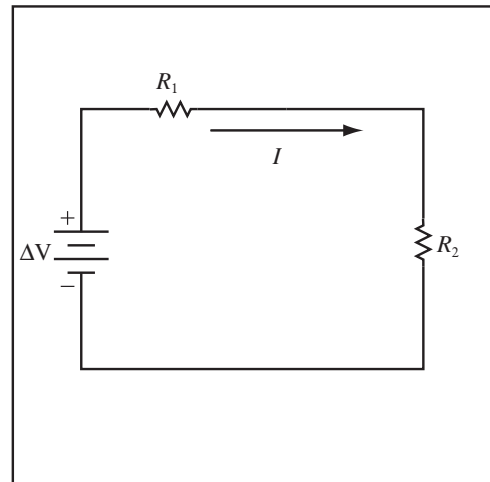

(d) **Compute Voltage Drop Across Capacitor:** Use the network properties (found in the previous section) to calculate the voltage drop between the points where the capacitor was connected before you redrew the circuit. This gives the potential difference across the capacitor. The capacitor is in parallel with R_2 , so they have the same potential drop

$$\Delta V_C = \Delta V_2 = 8.0\text{V}$$

(e) **Compute the Charge:** Use the Definition of Capacitance to compute the charge on the capacitor. By definition of capacitance,

$$Q_C = C \Delta V_C = (3.0 \times 10^{-6} \text{F}) \cdot (8.0\text{V}) = 24 \mu\text{C}$$

Example 23.3 Analyze Short Time Behavior of a Charging RC Circuit

Problem: The RC circuit shown below has circuit elements of the following values: $\Delta V = 12\text{V}$, $R_1 = 3.0\text{M}\Omega$, $R_2 = 6.0\text{M}\Omega$, and $C = 3.0\mu\text{F}$. When answering the following questions, assume that the circuit has *just* been closed (analysis in the short-time limit). What is the current through each resistor? What is the potential difference across each resistor?

Solution

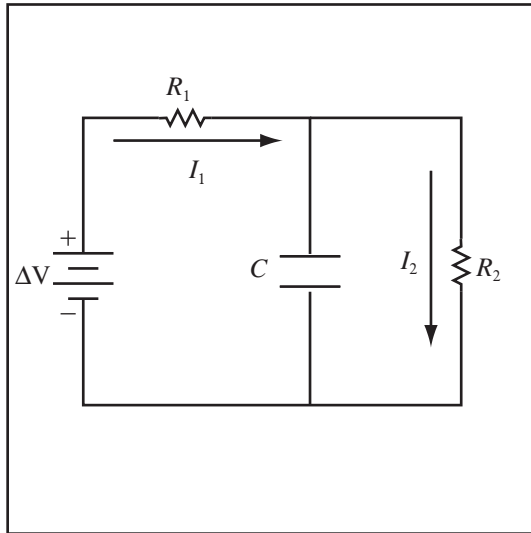

Definitions

$\Delta V = 12\text{V} \equiv$ Potential difference between battery terminals

$R_1 = 3.0\text{M}\Omega \equiv$ Resistance of first resistor

$R_2 = 6.0\text{M}\Omega \equiv$ Resistance of second resistor

$C = 3.0\mu\text{F} \equiv$ Capacitance of capacitor

$I_1 \equiv$ Current through first resistor

$I_2 \equiv$ Current through second resistor

$\Delta V_1 \equiv$ Potential difference across first resistor

$\Delta V_2 \equiv$ Potential difference across second resistor

$\Delta V_C \equiv$ Potential difference across capacitor

Strategy: Use the fact that at short times, the capacitors do not resist the current. Analyze the resulting DC circuit.

(a) Redraw the circuit replacing the capacitors with wires. Since the wire has less resistance than the resistor it is in parallel with, R_2 , the current flows through the wire instead of R_2 .

$$I_2 \approx 0\text{A}$$

$$\Delta V_2 \approx 0\text{V}$$

Since the capacitor is in parallel with R_2 , they have the same potential difference across the terminals

$$\Delta V_C = \Delta V_2 \approx 0\text{V}$$

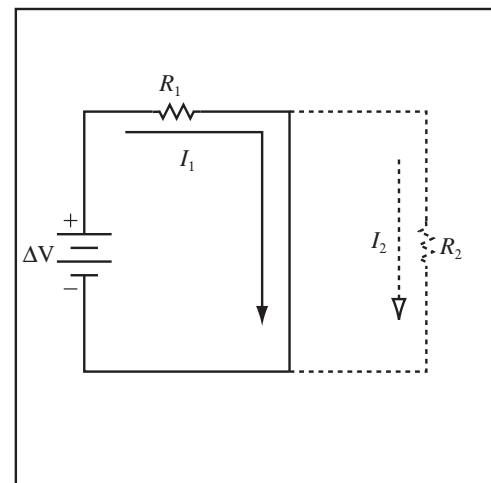

(b) **Solve the DC Circuit:** The resulting circuit is a simple DC circuit and the currents can be solved for using techniques for DC circuits. We can use Ohm's Law, $\Delta V = IR$, to find the current through R_1 . Since R_1 is the only circuit element across the battery, the potential drop across it is the same as that across the battery, $\Delta V = \Delta V_1$.

$$I_1 = \Delta V_1 / R_1 = 12\text{V} / (3.0 \times 10^6 \Omega) = 4.0\mu\text{A}$$

23.2 RC Circuits

23.2.1 General Behavior of RC Circuits

Both charging and discharging RC circuits have exponential time dependencies. The rate of change of any factor in the circuit is controlled by an exponential factor $e^{-\frac{t}{\tau}}$ where t is the time and τ is the time constant. All circuit quantities, charge, current, and potential difference change with this time dependence. The number e is not the electric charge, it is the base of the natural logarithm, $\ln(e) = 1$. For quantities which decrease with time,

the quantity decays to $1/e \approx 1/2.72 \approx 1/3$ of its initial value in one time constant. Quantities which increase with time reach $1 - \frac{1}{e} \approx \frac{2}{3}$ their final value in one time constant.

Time Constant, τ : The time constant of an RC circuit is $\tau = RC$, where R is the total resistance the capacitor charges or discharges through and C is the total capacitance.

Base of the Natural Logarithm: The number e is the base of the natural logarithm. To a few decimal places $e = 2.7182818$. e is a constant that is programmed into some TI calculators, or you can use the function $e^x = e$.

Example 23.4 Approximate Time Constant Solution

Problem: A charged capacitor discharges through a light bulb. After 10s, the bulb dims to one-third its original brightness. Without calculation, what approximately is the time constant? Justify your answer.

Solution

$$e^{-1} \approx \frac{1}{3} = e^{-\frac{\tau}{10}},$$

so $\tau \approx 10\text{s}$.

23.2.2 Exponential Time Dependence

Before working out the time dependence of the parameters of an RC circuit from the physics, let's review the properties of exponential curves.

Decreasing Exponential Curve: Some features of RC circuits decrease with time. They have a general time dependence of

$$\exp(-t/\tau)$$

which at time $t = 0$ is one and decreases to 0 at long times. The graph below might be the voltage across a resistor in a discharging RC circuit with initial voltage, $\Delta V_0 = 10V$, and time constant $\tau = 10s$. τ is the time required to the initial voltage ΔV_0 to decay to $\Delta V_0/e = \Delta V_0/2.72 = 0.37\Delta V_0$.

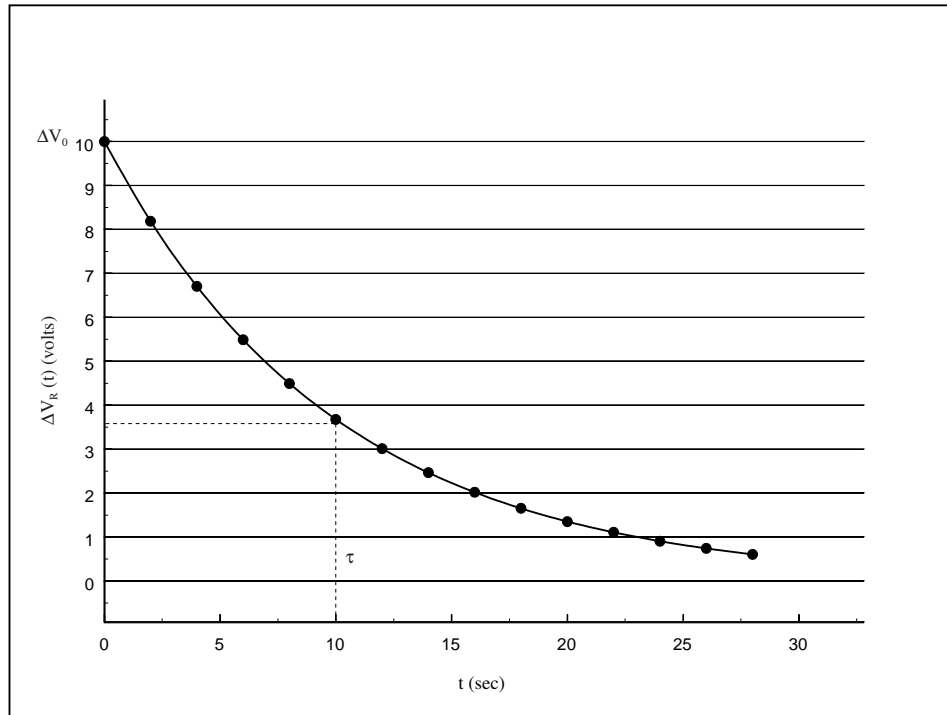

Increasing Exponential Curve: Some features of RC circuits increase with time. They have a general time dependence of

$$1 - \exp(-t/\tau),$$

which at time $t = 0$ is zero and increases to 1 at long periods of time. The graph below might be the voltage across a charging capacitor with final voltage, $\Delta V_f = 10\text{V}$, and time constant $\tau = 10\text{s}$. The time τ is the time required for the voltage to reach $1 - \frac{1}{e} = 0.63$ of the final voltage.

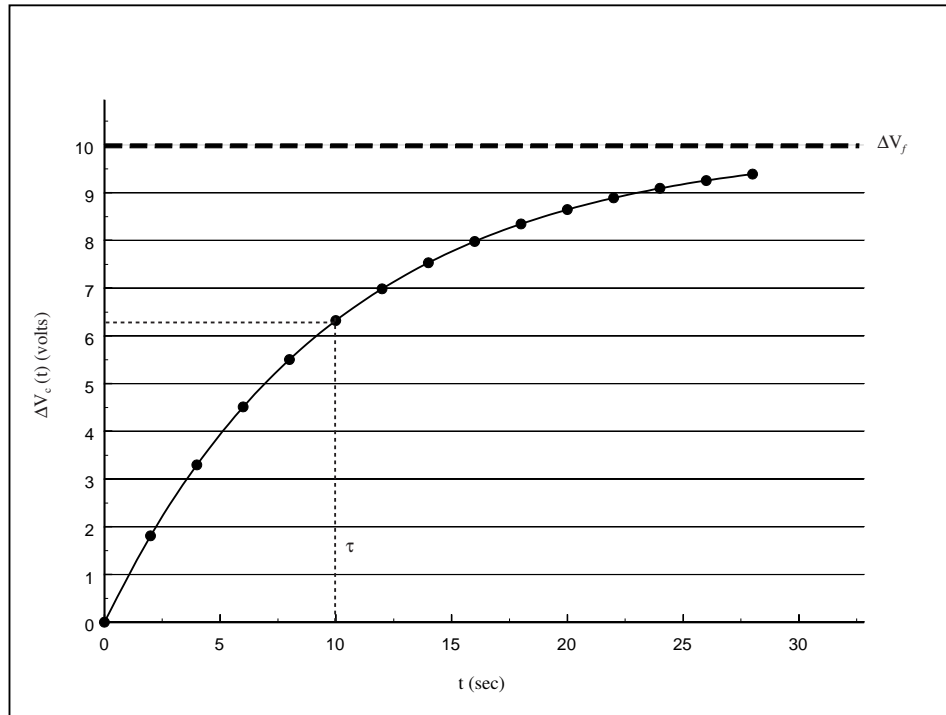

Exponential is Dimensionless: The thing, X , in the exponential function $\exp(X) = e^X$ or the log function $\ln(X)$ cannot have any dimensions, so if the dimensions fail to cancel, you blew it.

Solving an Equation Containing Exponentials : If we have the equation, $Y = \exp(X)$, then we can take the natural log of both sides to get $X = \ln(Y)$. If however we have the equation $Y = 1 - \exp(X)$ then the log of both sides is $\ln(Y) = \ln(1 - \exp(X))$. To solve this equation, we rearrange before taking the log, $\exp(X) = 1 - Y$, or $X = \ln(1 - Y)$.

23.2.3 Discharging RC Circuits

An RC circuit is drawn to the right. The charge on the positive capacitor plate changes as a function of time, $Q(t)$, causing a current through the circuit. The charge and electric field of the capacitor are drawn. Initially the capacitor has charge $Q(0)$. Since opposite charges attract, the initial charge on the capacitor flows through the resistor until at long periods of time, the capacitor becomes uncharged. The corners of the circuit are labelled and applying Kirchhoff's loop equation to the one loop circuit gives,

$$\Delta V_{AB} + \Delta V_{BC} + \Delta V_{CD} + \Delta V_{DA} = 0$$

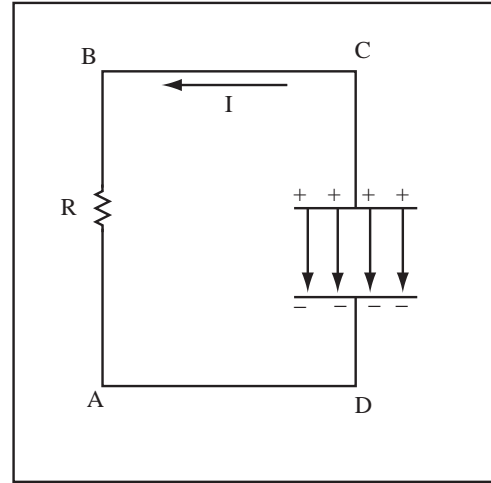

The potential differences $\Delta V_{BC} = \Delta V_{DA} = 0$ because the potential difference across a perfect wire is zero. The potential difference $\Delta V_{AB} = +IR$ because the potential drops as current crosses a resistor. The potential across the capacitor is $\Delta V_{CD} = -Q/C$ because potential decreases in the direction of the electric field. Substituting into the loop equation gives,

$$IR - \frac{Q}{C} = 0$$

For the direction of I chosen, the current is related to the charge on the positive capacitor plate by

$$I = -\frac{dQ}{dt}$$

because a decrease in the charge on the plate causes a positive current.

$$-R\frac{dQ}{dt} - \frac{Q}{C} = 0$$

Rearranging gives,

$$\frac{dQ}{Q} = -\frac{1}{RC}dt$$

Integrate from time 0 when the capacitor has charge $Q(0)$ to time t ,

$$\int_{Q(0)}^{Q(t)} \frac{dQ}{Q} = -\frac{1}{RC} \int_0^t dt$$

$$\ln(Q(t)) - \ln(Q(0)) = \frac{-t}{RC}$$

Use a property of logarithms, $\ln(B) - \ln(A) = \ln(B/A)$,

$$\ln(Q(t)/Q(0)) = \frac{-t}{RC}$$

Exponentiate both sides. We will write the exponential both as $\exp(x)$ and e^x .

$$\exp\left(\ln(Q(t)/Q(0))\right) = \exp(-t/RC)$$

Use the property of exponentials that $\exp(\ln(x)) = x$, to yield the final result

$$Q(t) = Q(0)e^{-\frac{t}{\tau}}$$

where $\tau = RC$. All other circuit properties are related to $Q(t)$ as shown in the table below:

Circuit Property	Time Dependence
Charge of Capacitor	$Q(t) = Q(0)e^{-\frac{t}{\tau}}$
Current	$I(t) = -\frac{dQ}{dt} = \frac{Q(0)}{RC}e^{-\frac{t}{\tau}} = I(0)e^{-\frac{t}{\tau}}$
Potential Difference Across Capacitor	$\Delta V_C(t) = \frac{Q(t)}{C} = \frac{Q(0)}{C}e^{-\frac{t}{\tau}} = \Delta V_C(0)e^{-\frac{t}{\tau}}$
Potential Difference Across Resistor	$\Delta V_R(t) = RI(t) = \Delta V_R(0)e^{-\frac{t}{\tau}}$

Example 23.5 Analyze Discharging Behavior of an RC Circuit

Problem: A 3.0nF capacitor is charged to the point that it has a 6.0V potential difference between the plates. This charged capacitor is then placed in series with a $9.0\text{M}\Omega$ resistor and allowed to discharge. What is the time-dependent charge on the capacitor? What is the time-dependent current through the resistor?

Solution

Definitions

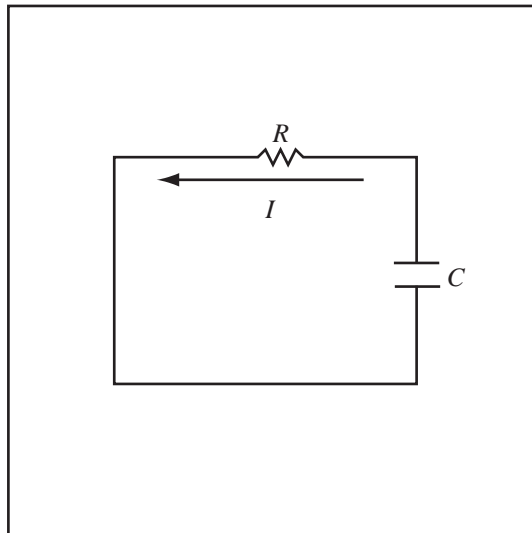

- $R_1 \equiv$ Resistance of Resistor 1
- $\Delta V_0 \equiv$ Initial Potential Difference Across C
- $C \equiv$ Capacitance of the capacitor
- $I(t) \equiv$ Current in the circuit
- $Q(t) \equiv$ Charge on the Capacitor
- $I_0 \equiv$ Initial Current
- $Q_0 \equiv$ Initial Charge on Capacitor

Strategy: Use formula for discharging capacitor.

(a) Compute Initial Charge, Q_0 , on Capacitor: By definition of capacitance, the initial charge on the capacitor is $Q_0 = C\Delta V_0$.

$$Q_0 = C\Delta V_0 = (3.0 \times 10^{-9}\text{F}) \cdot (6.0\text{V}) = 18\text{nC}$$

(b) Compute Time Constant, τ : The time constant of an RC circuit is $\tau = RC$,

$$\tau = R_1C = 9.0 \times 10^6\Omega \cdot 3.0 \times 10^{-9}\text{F} = 27\text{ms}$$

(c) Use Discharging Form for Charge: Since the charge on the capacitor starts at its highest value Q_0 and decays toward zero, the correct form of the time dependence is a decaying exponential,

$$Q(t) = Q_0 \exp(-t/\tau)$$

$$Q(t) = (18 \times 10^{-9}\text{C}) \exp[-t/(27 \times 10^{-3}\text{s})]$$

(d) Compute Initial Current, I_0 , Through Resistor: Initially, the voltage across the capacitor is V_C , so the initial current is by Ohm's Law

$$I_0 = \frac{\Delta V_C}{R_1} = 6.0\text{V}/9.0\text{M}\Omega = \frac{2}{3} \times 10^{-6}\text{A}$$

(e) Use Discharging Form of Current: Since the current in the circuit starts at its highest value I_0 and decays toward zero, the correct form of the time dependence is a decaying exponential,

$$I(t) = I_0 \exp(-t/\tau)$$

$$I(t) = \left(\frac{2}{3} \times 10^{-6} \text{A}\right) \exp[-t/(27 \times 10^{-3} \text{s})]$$

Example 23.6 Graphical RC Decay Problem

Problem: A capacitor is allowed to discharge through a 100Ω resistor and the voltage across the capacitor is measured using a voltmeter and plotted below.

- Write the equation for $\Delta V_C(t)$, the voltage across the capacitor as a function of time, and give numerical values for any constants you introduce including the time constant τ .
- Compute the capacitance of the capacitor.
- How long does it take the voltage across the capacitor to decay to $\frac{1}{4}$ of its initial value? Solve the equation you wrote using the constants in part (a) instead of reading them off of the graph.

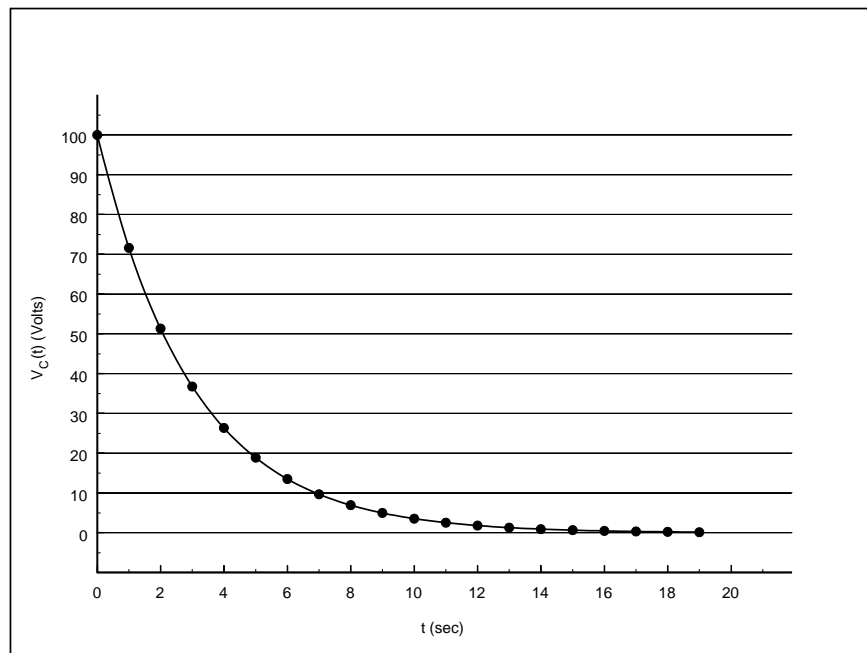

Solution to Part(a)

The potential difference across the capacitor decays as a function of time, so the time dependence is

$$\Delta V_C(t) = \Delta V_{C0} e^{-\frac{t}{\tau}}$$

where $\Delta V_{C0} = 100\text{V}$ which can be read directly from the graph. The time constant $\tau = RC$ is the time for the voltage to decay to $e^{-1} = 0.37$ of its initial value, so it is the time when the voltage crosses $(0.37)(100\text{V}) = 37\text{V}$, which can be read from the graph as $\tau = 3\text{s}$.

Solution to Part(b)

The capacitance of the capacitor is $C = \tau/R = 3\text{s}/100\Omega = 0.03\text{F}$.

Solution to Part(c)

The time for the voltage to fall to $\frac{1}{4}$ of its initial value is found by solving the decay equation,

$$0.25 = \frac{\Delta V_C}{\Delta V_{C0}} = e^{-\frac{t}{\tau}}$$

$$\ln(0.25) = -\frac{t}{\tau}$$

$$t = -\tau \ln(0.25) = -(3\text{s})\ln(0.25) = 4.2\text{s}$$

23.2.4 Charging RC Circuit Behavior

A charging RC circuit connects an uncharged capacitor and a resistor in series with a battery at time $t = 0$. The capacitor charges and gradually blocks the current in the circuit until as $t \Rightarrow \infty$, the capacitor is fully charged and no current flows in the circuit. The table below summarizes the time dependence of a charging RC circuit. Note, some quantities increase with time and some quantities decay with time.

Circuit Property	Time Dependence
Charge of Capacitor	$Q(t) = Q(\infty)(1 - e^{-\frac{t}{\tau}})$
Current	$I(t) = I(0)e^{-\frac{t}{\tau}}$
Potential Difference Across Capacitor	$\Delta V_C(t) = \Delta V_C(\infty)(1 - e^{-\frac{t}{\tau}})$
Potential Difference Across Resistor	$\Delta V_R(t) = RI(t) = \Delta V_R(0)e^{-\frac{t}{\tau}}$

In the table, $Q(\infty)$ is the charge on the capacitor at long times and $\Delta V_C(\infty)$ is the potential difference across the capacitor at long times.

Example 23.7 Analyze Charging Behavior of an RC Circuit

Problem: An uncharged 3.0nF capacitor is in series with a $9.0\text{M}\Omega$ resistor. These are then connected across a 6.0V battery and the capacitor is allowed to charge. What is the time-dependent charge on the capacitor? What is the time-dependent current through the resistor?

Solution

Definitions

- $R_1 \equiv$ Resistance of Resistor 1
- $\Delta V_1 \equiv$ Potential Difference Across Battery
- $C \equiv$ Capacitance of the capacitor
- $I(t) \equiv$ Current in the circuit
- $Q(t) \equiv$ Charge on the Capacitor
- $I_0 \equiv$ Initial Current
- $Q_f \equiv$ Final Charge on Capacitor = $Q(\infty)$

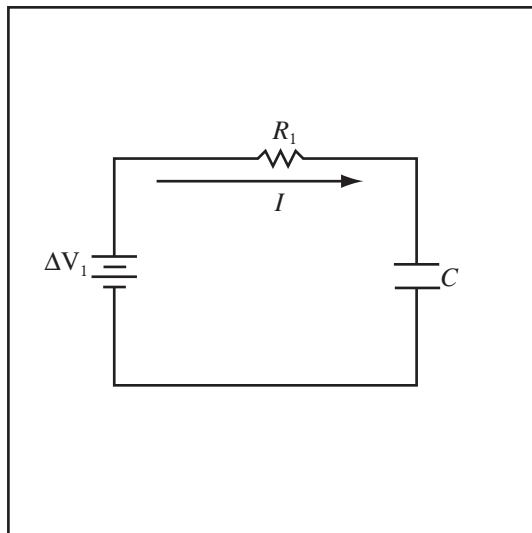

Strategy: Use formula for charging capacitor.

(a) Compute Final Charge, Q_f , on Capacitor: At long times, the capacitor draws no current, so using the loop equation for the circuit $\Delta V_1 - IR_1 - \Delta V_C = 0$ with $I_f = 0$, gives $\Delta V_1 = \Delta V_C$, and by definition of capacitance, $Q_f = \Delta V_C C$,

$$Q_f = 6.0\text{V} \cdot 3.0 \times 10^{-9}\text{F} = 18 \times 10^{-9}\text{C} = 18\text{nC}$$

(b) **Compute Time Constant, τ :** The time constant of an RC circuit is

$$\tau = R_1 C = 9.0 \times 10^6 \Omega \cdot 3.0 \times 10^{-9} \text{F} = 27 \text{ms}$$

(c) **Use Charging Form for Charge on Capacitor:** Since the charge on the capacitor starts at zero and increases toward Q_f , an increasing exponential time dependence is appropriate,

$$Q(t) = Q_f(1 - \exp(-t/\tau))$$

$$Q(t) = (18 \times 10^{-9} \text{C}) \{1 - \exp[-t/(27 \times 10^{-3} \text{s})]\}$$

(d) **Compute Initial Current, I_0 , Through Resistor:** Use Ohm's Law to calculate initial current, the current is $I_0 = \Delta V_1 / R_1$

$$I_0 = 6.0 \text{V} / 9.0 \text{M}\Omega = \frac{2}{3} \times 10^{-6} \text{A}$$

(e) **Use Charging Form of Current:** The current has its maximum value at $t = 0$ and then decays toward zero, so the proper form of the time dependence is

$$I(t) = I_0 \exp(-t/\tau)$$

$$I(t) = \left(\frac{2}{3} \times 10^{-6} \text{A}\right) \{\exp[-t/(27 \times 10^{-3} \text{s})]\}$$

Example 23.8 RC Circuit Problem

Problem: A $1000 \mu\text{F}$ capacitor is charged to 12V by a car battery through a 10000Ω resistor.

- What is the time constant for the charging process?
- Write the function for the potential difference across the capacitor if it begins charging at $t = 0$.
- After a long time, how much energy is stored in the capacitor?

Solution to Part(a)

The time constant for an RC circuit is $\tau = RC = (1000 \mu\text{F})(10000 \Omega) = 10 \text{s}$.

Solution to Part(b)

For a charging capacitor, the potential difference starts at zero and charges to the applied voltage,

$$\Delta V_C(t) = \Delta V_f(1 - e^{-\frac{t}{\tau}})$$

where $\Delta V_f = 12 \text{V}$.

Solution to Part(c)

The energy stored in a capacitor is

$$U = \frac{1}{2} C \Delta V^2 = \frac{1}{2} (1000 \mu\text{F})(12 \text{V})^2 = 72000 \mu\text{J} = 0.072 \text{J}$$

23.3 Graphing RC Circuits

The behavior of an RC circuit involves a time dependence which can be measured and graphed. Interpreting those graphs is a key skill in understanding RC circuits.

Determine Time Dependence from Graph: If the plot increases toward a maximum value for a long period of time, then the time dependence is $1 - \exp(-t/\tau)$. If the plot begins at its highest value and decays toward zero, then the time dependence has the functional form $\exp(-t/\tau)$.

Determine Leading Constant for Decaying Exponential: For a decaying exponential time dependence of the form $\Delta V(t) = \Delta V_0 \exp(-t/\tau)$, the constant ΔV_0 is $\Delta V(0)$, the value of the function at time zero.

Determine Leading Constant for Increasing Exponential: For an increasing exponential time dependence of the form $\Delta V(t) = \Delta V_f(1 - \exp(-t/\tau))$, the constant ΔV_f is $\Delta V(t \rightarrow \infty)$; so it is the value $\Delta V(t)$ approaches as t becomes large.

Compute Time Constant from Point: The time constant can be approximated by taking any point off the graph and using this point to solve for τ , as shown in Example 23.9 Use a Potential versus Time Plot to Determine RC Circuit Properties.

Example 23.9 Use a Potential versus Time Plot to Determine RC Circuit Properties

Problem: A capacitor is charged to some value, then connected in series with a 100Ω resistor and allowed to discharge. A measurement of the potential difference across the capacitor is shown in the figure below. Compute the time constant of the circuit, the capacitance of the capacitor, and the initial charge stored on the capacitor.

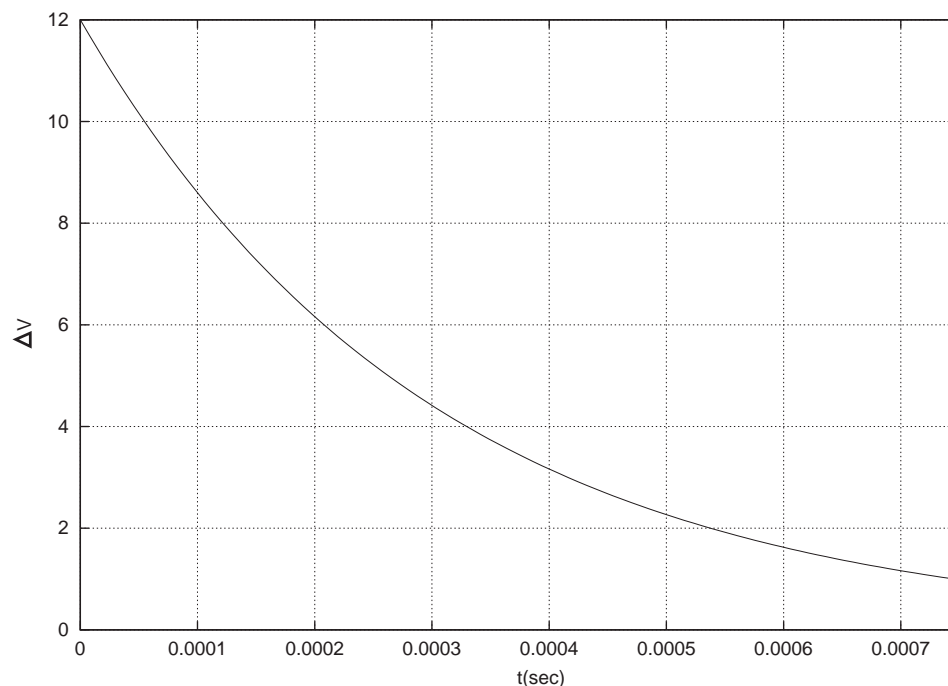

Solution

Strategy: Determine the time constant from the plot, then use the definition of the time constant and the definition of capacitance.

(a) Determine Form of Time Dependence: Examine the graph and determine the functional form of the time dependence, whether it is $\exp(-t/\tau)$ or $1 - \exp(-t/\tau)$. Read the overall constant off the curve. Since the curve begins at its maximum value and decays toward zero, the time dependence has the form

$$\Delta V_C = \Delta V_0 \exp\left(-\frac{t}{\tau}\right).$$

The constant $\Delta V_0 = 12\text{V}$ is voltage at $t = 0$.

(b) Determine the Time Constant: Choose any point on the curve. Determine the time t_s and the potential $\Delta V(t_s)$ for that particular point. Solve time dependence for τ , at $t_s \approx 0.00054\text{s}$ the potential difference is $\Delta V_C(t_s) = 2\text{V}$. Solve the time dependence for the time constant,

$$\begin{aligned}\Delta V_C(t_s) &= \Delta V_0 \exp\left(-\frac{t_s}{\tau}\right) \\ \ln\left(\frac{\Delta V_C}{\Delta V_0}\right) &= \ln\left(\exp\left(-\frac{t_s}{\tau}\right)\right) = -\frac{t_s}{\tau} \\ \tau &= -\frac{t_s}{\ln\left(\frac{\Delta V_C}{\Delta V_0}\right)}\end{aligned}$$

The time constant is then

$$\tau = -\frac{0.00054\text{s}}{\ln(2\text{V}/12\text{V})} = 0.00030\text{s} = 0.3\text{ms}$$

(c) Compute the Capacitance: The capacitance can be determined from the definition of the time constant, $\tau = RC$. Using definition of the time constant $C = \tau/R$ gives

$$C = 0.00030\text{s}/100\Omega = 3 \times 10^{-6}\text{F} = 3\mu\text{F}$$

(d) Compute the Initial Charge Stored: Use the definition of capacitance, $C = Q/\Delta V$, to determine the initial charge stored on the capacitor. The initial charge is given by $Q_0 = C\Delta V_0$

$$Q_0 = 3 \times 10^{-6}\text{F} \cdot 12\text{V} = 36 \times 10^{-6}\text{C} = 36\mu\text{C}$$

Example 23.10 Sketch Voltage Curve for RC Circuit

Problem: An RC circuit is constructed from a 12V battery, a $1\text{M}\Omega$ resistor, and a $5000\mu\text{F}$ capacitor in series.

(a) What is the time constant of the circuit?

(b) In the space below, make an approximate sketch of the voltage across the capacitor as the RC circuit charges.

Solution to Part(a)

The time constant is $\tau = RC = (5000\mu\text{F})(1 \times 10^6\Omega) = 5000\text{sec}$.

Solution to Part(b)

In one time constant, the voltage across the capacitor reaches $(1 - e^{-1}) = 0.63$ of its final value.

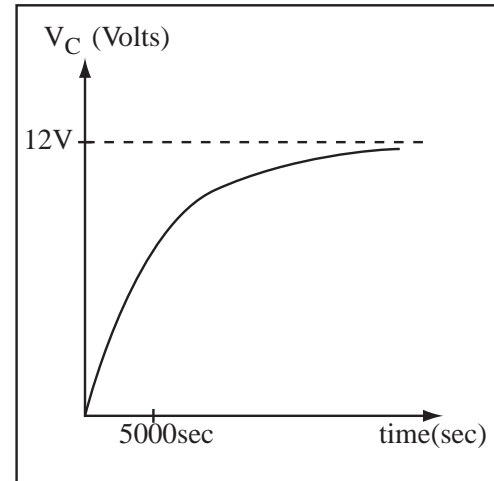

Chapter 24

Final Topics Test 2

24.1 What Does a Capacitor Do?

In physics lab, we use capacitors as energy storage devices. A battery is an energy storage device designed to provide energy to a circuit at a roughly constant potential difference. A battery will provide energy for hours before fully discharging. We can adjust the rate at which a battery provides energy to a circuit by changing the resistance in a circuit. The rate energy can be provided by a battery is restricted by the internal resistance of the battery. Capacitors also store energy, but deliver it back with a changing voltage. The rate at which energy is stored or returned can be adjusted by changing the resistance and therefore the time constant. A capacitor's internal resistance is very small, so if we wish, we can get energy out of a capacitor very fast.

We will use this property to fire one of our energy weapons, called a Gauss Gun. The Gauss gun is just a coil of wire wrapped around a glass tube. The gun fires a magnetic slug. We use a $1000\mu\text{F}$ capacitor to power the Gauss gun. This capacitor is charged to 150V by a power supply in about 5s . So if $\tau = 5\text{s} = RC$, then $R = 5\text{s}/0.001\text{F} = 5000\Omega$ and the maximum current in the charging process is $I_{max} = \Delta V/R = 150\text{V}/5000\Omega = 0.3\text{A}$, a very reasonable current. We, then, connect the capacitor to the Gauss Gun which has a resistance of 0.1Ω . The capacitor delivers a peak current of $V/R = 150\text{V}/0.1\Omega = 1500\text{A}$, which is a very big current. The capacitor returns the energy we placed in it in a time $\tau = RC = (0.1\Omega)(0.001\text{F}) = 1 \times 10^{-4}\text{s}$. We put in energy slowly and got it back fast.

Capacitors are one of the most common electric circuit elements and are used to smooth signals. Since capacitors store energy, they maintain their own potential difference, and act to resist a change in potential. The two figures below show the result of applying a step in potential to a circuit with no capacitance and to a circuit with capacitance.

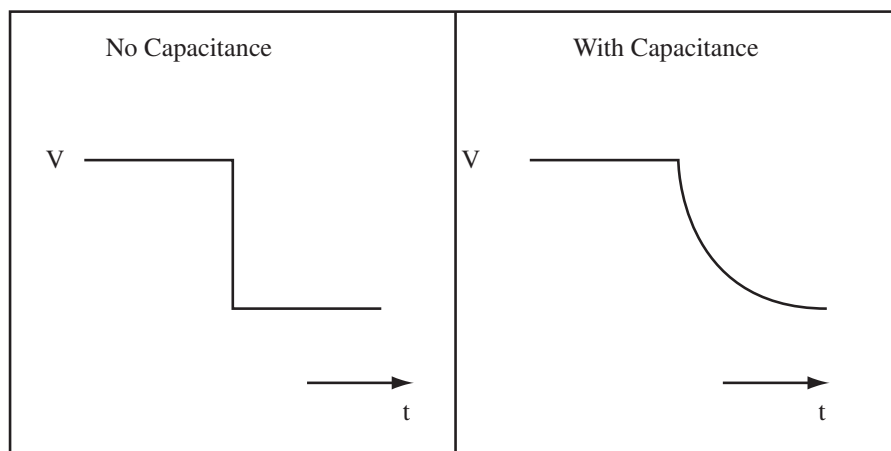

The voltage step in the circuit with capacitance is smoothed out. If we return to the plumbing analogy developed in lab, a capacitor acts like a pressure tank. When pressure rises in a system the capacitor takes up

some of the excess. When pressure falls, the capacitor acts as a reservoir to maintain the pressure.

24.2 Revisiting Shielding by Conductors

The electric field is zero in a conductor. This means that if a conductor separates two regions of space the field in one region does not affect the field in the other region. The conductor isolates the two regions. The figure below shows a conducting slab and a conducting shell in the field of a positive charge. The conducting slab has zero net charge, so there must be a charge density on its right surface to balance the charge density on the left surface. However, the charge density on the right surface spreads uniformly over the surface just as if the golf tube was not there.

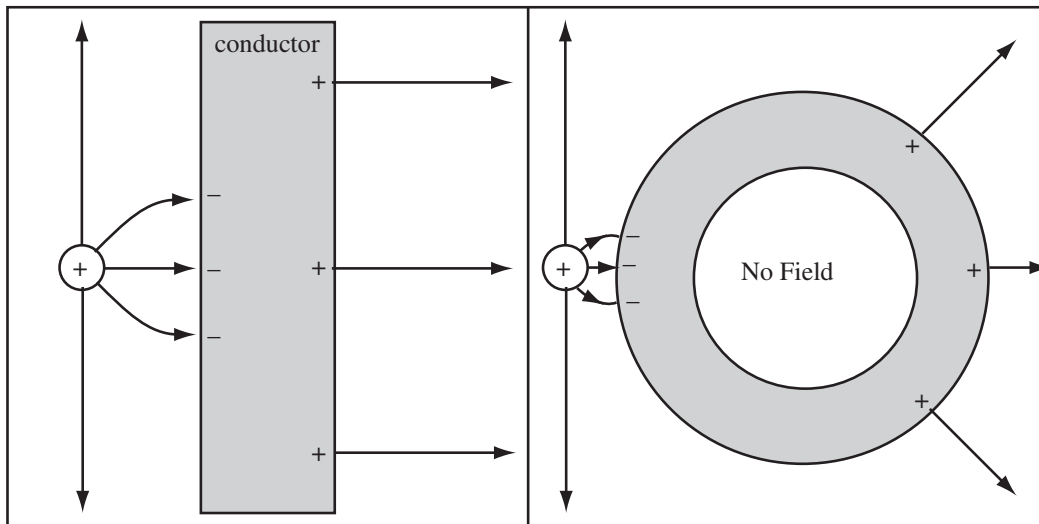

We can reverse the situation for the conducting shell and place the charge inside as shown in the example below.

Example 24.1 Charge inside a Conducting Shell

Problem: On the figure to the right,

- sketch the electric field lines emphasizing important features to make sure you demonstrate your understanding of electric field maps. Draw in any induced charge. The object is an infinite cylindrical uncharged conductor, with an infinite line charge of charge density $+\lambda$ that is parallel to the cylinder's axis, but off center.
- Using $>$, $<$ and/or $=$ signs, rank the electric field at points a , b , c , and d . Are any of these zero. If so, why?

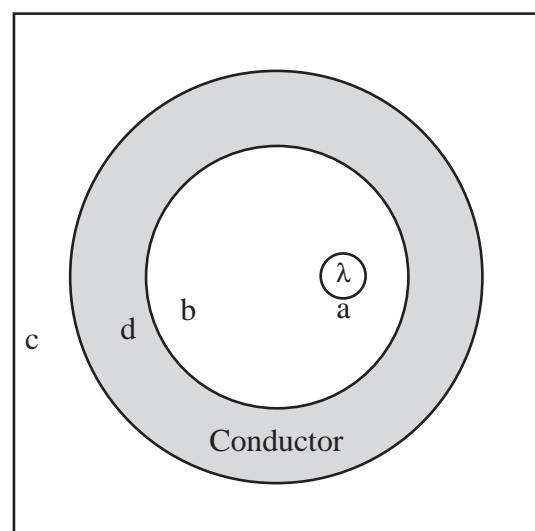

Solution to Part(a)

The drawing should have the following features: The field lines should leave λ symmetrically and radially. The lines should be evenly spaced about λ . The lines should curve and hit the inner surface of the conductor perpendicular to the surface. An equal number of lines should leave the outer surface of the conductor radially. + charge should be drawn where lines begin and - charge should be drawn where lines end.

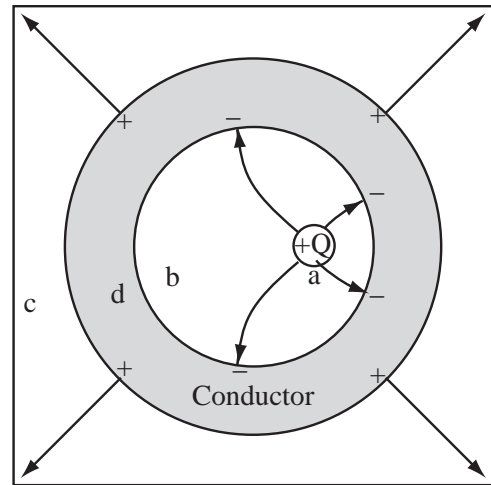

Solution to Part(b)

$E_a > E_b > E_c > E_d = 0$. $E_d = 0$ because the region is inside a conductor.

Finally, we can consider grounding the conductor. The surface charge densities not held in place by the charged objects will escape to ground, completely isolating one region from the charge in the other region.

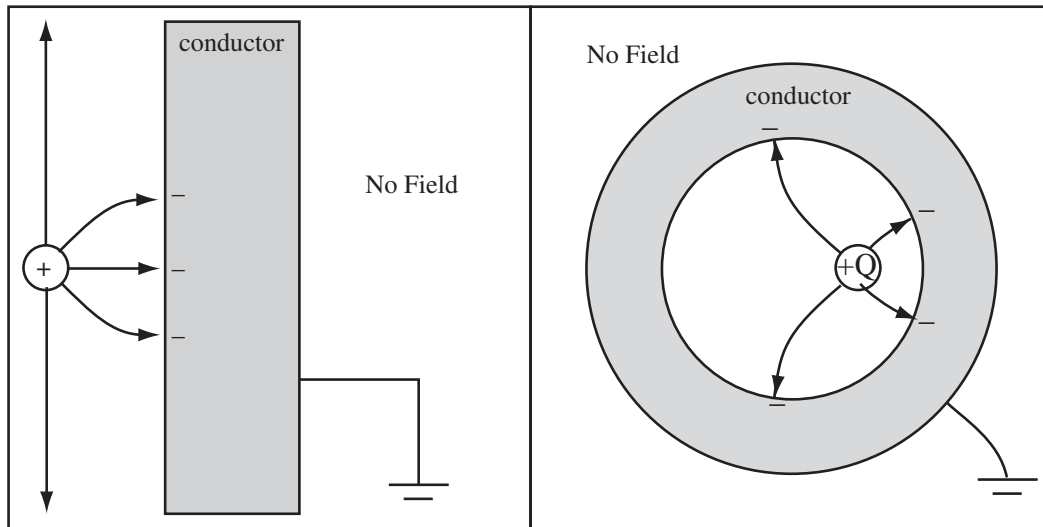

Chapter 25

Biot-Savart Law

Electric charges produce electric fields. **Moving** electric charges produce magnetic fields. This might come as something of a surprise, since as a kid you probably discovered (without really saying it) that “magnets make magnetic fields.” Why don’t we start from this point, using magnets as our basic building blocks? We might hope for a nice analogy between electric charge as the source of electric field and something else as the source of magnetic field, but it turns out that there is no such thing as magnetic “charge”. Magnets can be explained in terms of the motion of the electric charges they contain. So we begin with the more basic concept of moving charges. We will come back to magnets later.

25.1 No Magnetic Charge

25.1.1 No Magnetic Charge

It would be nice at this point to write down a Coulomb’s law for magnetism and tell you everything you’ve learned for electric fields carries over for magnetic fields. The universe is not that cooperative.

No Magnetic Charge: There is no magnetic analogue to an electric point charge. Magnetic charge simply does not exist. The simplest magnetic fields are therefore dipole fields, instead of monopole fields. Physicists sometime state this as, “no magnetic monopoles”.

The absence of magnetic charge means the expression which corresponds to Gauss’ Law for magnetism is particularly simple.

Magnetic Flux Through any Closed Surface (Maxwell II): The mathematical expression of non-existence of magnetic charge is that the magnetic flux, ϕ_m , through any closed surface is always zero.

$$\phi_m = \int_S (\vec{B} \cdot \hat{n}) dA = 0$$

where \vec{B} is the magnetic field on the surface. Note the similarity to Gauss’ Law, where the flux from the electric field is equal to $Q_{enclosed}/\epsilon_0$, but for magnetic fields, the magnetic charge enclosed is always zero. This is the second Maxwell equation, Gauss’ law is the first.

The fact that there is no magnetic charge is a restriction on the kind of magnetic field map we can draw.

Example 25.1 Identifying Valid Magnetic Field Maps

Problem: In some region, you are told the magnetic field is $\vec{B} = B_0 x \hat{x}$. Is this a possible magnetic field? Why or why not?

Solution

This cannot be a valid field, since it produces a net flux out of a parallel-piped with sides \perp to the x -axis.

Example 25.2 Possible Magnetic Field Maps

Problem: Is the field map to the right an electric field, magnetic field, or possibly both? Why?

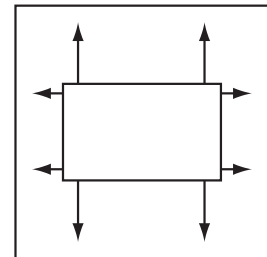

Solution

Since net flux exits the region, it must be an electric field map. The net flux exiting any region for a magnetic field is zero.

25.1.2 Maxwell's Equations Part I

Four equations, called Maxwell's equations, after James Clerk Maxwell, the physicist who completed the equations, completely describe the behavior of electric and magnetic fields. The Lorentz force describes how these fields act on charged particles. We have been working with two of Maxwell's equations for weeks, Gauss' law and Faraday's law in the special case where there are no changing magnetic fields. Over the next few weeks we will complete this set of equations and I will show the addition of new pieces of Maxwell's equations as we complete our understanding of the behavior of the electromagnetic field.

Maxwell's Equations Part I: Maxwell's Equations and the Lorentz force as introduced to this point are:

Maxwell's Equations

Gauss' Law: $\int_S (\vec{E} \cdot \hat{n}) dA = \frac{Q_{\text{enclosed}}}{\epsilon_0}$

No Magnetic Monopoles: $\int_S (\vec{B} \cdot \hat{n}) dA = 0$

Faraday's Law (Independence of Path): $\oint_C \vec{E} \cdot d\vec{\ell} = 0$ when there are no changing magnetic fields.

Ampere's Law:

Lorentz Force

$$\vec{F} = q\vec{E} \quad \text{when there are no magnetic fields}$$

One Maxwell's equation is simply missing and is the integral expression of the Biot-Savart law of next section. A number of the equations have restrictions that we will remove over the next few weeks.

25.2 Biot-Savart Law

A magnetic field is produced by moving electric charge, which might be charged particles in flight, electric current flowing in a wire, or electrons 'spinning' and orbiting the nucleus of an atom. Magnetic fields are different from electric fields in several ways. By now you should have a feel for the way an electrostatic \vec{E} field "radiates" from (or toward) electric charges. Mathematically, \vec{E} for a point charge is directed along the line from the source charge to the field point. Magnetic field isn't that simple—it has a sort of "sideways" character.

25.2.1 Mathematical Preliminaries - The Cross Product

Since there is no magnetic charge, the actual law that allows the calculation of the magnetic field from the charge is a bit more complicated. It involves a new vector operation, the *cross product*. The cross product is an operation which takes two vectors and returns a third vector perpendicular to both, with length equal to the area of the parallelogram formed by the two vectors. If the cartesian form of the two vectors is known, the cross product can be defined:

Definition of Cross-Product in Cartesian Coordinates:

$$\vec{C} = \vec{A} \times \vec{B} = (A_y B_z - A_z B_y)\hat{x} + (A_z B_x - A_x B_z)\hat{y} + (A_x B_y - A_y B_x)\hat{z}$$

We will rarely use this definition to compute the cross product. It is usually easier to compute the magnitude of the cross product, then use the right hand rule to compute the direction.

The Magnitude of the Cross Product : The magnitude of a cross-product is

$$|\vec{A} \times \vec{B}| = AB \sin \theta$$

where A and B are the magnitudes of \vec{A} and \vec{B} respectively, and θ is the angle smaller than 180 degrees between \vec{A} and \vec{B} . Note that since sine is greatest when the angle is 90 degrees, a cross product is largest when the two vectors are perpendicular.

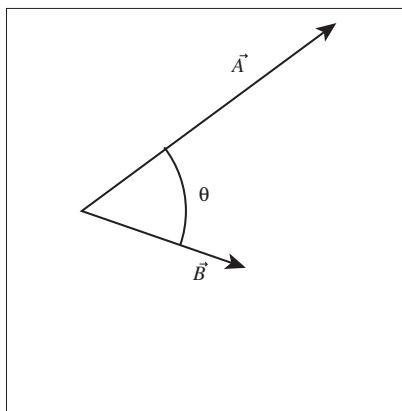

The above means that the cross-product of two parallel vectors or a vector with itself is zero. The magnitude of the cross-product of two perpendicular vectors is $|\vec{C}| = |\vec{A} \times \vec{B}| = |\vec{A}||\vec{B}|$.

The “Right-Hand Rule” (RHR) :

To find the direction of $\vec{C} = \vec{A} \times \vec{B}$, point the fingers of your right hand in the direction of \vec{A} . Then rotate your wrist around the axis formed by \vec{A} until your hand is in a position to allow curling your fingers in the direction of \vec{B} through an angle less than 180° . (Sometimes this gets very awkward! You might have to stand on your head or turn around to achieve it.) Your thumb will then point in the direction of \vec{C} .

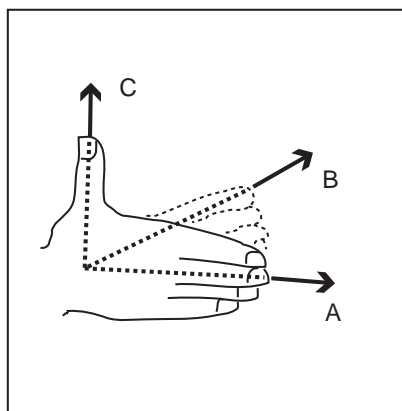

Avoid these pitfalls: Make sure you are using your *right* hand in all these manipulations! (We laugh ourselves silly when we see students' left hands in motion during a test.) Also make sure you do things in the right order; $\vec{A} \times \vec{B}$ is not the same as $\vec{B} \times \vec{A}$ —they differ by a minus sign—so you must align your fingers with the *first* vector in the cross product, then curl them into the *second* vector in the cross product, not the other way around.

Example 25.3 Cross-Product Example

Problem: Two vectors have values $\vec{A} = (1, 2, 3)$ and $\vec{B} = (5, 2, 1)$. Compute $\vec{C} = \vec{A} \times \vec{B}$.

Solution

$$\begin{aligned}\vec{C} &= \vec{A} \times \vec{B} = (A_y B_z - A_z B_y)\hat{x} + (A_z B_x - A_x B_z)\hat{y} + (A_x B_y - A_y B_x)\hat{z} \\ \vec{C} &= (2 - 6)\hat{x} + (15 - 1)\hat{y} + (2 - 10)\hat{z} = -4\hat{x} + 14\hat{y} - 8\hat{z}\end{aligned}$$

Because of the form of the physical laws governing magnetic fields, we have to work in three dimensions. When a three-dimensional coordinate system is drawn, you must make choices about the direction of the axes. This choice must be made by some criteria or all the signs of the numbers we compute are arbitrary.

Right and Left Handed Coordinate Systems: When we draw a three-dimensional coordinate system on a flat piece of paper, we can choose the positive directions for two of the axes in any direction we want. The third axis must be chosen so $\hat{x} \times \hat{y} = \hat{z}$. Such a coordinate system is called a right-handed coordinate system and will give us correct signs. If we choose the third axis so that $\hat{x} \times \hat{y} = -\hat{z}$, we have drawn a left handed coordinate system and all the quantities we compute will be incorrect.

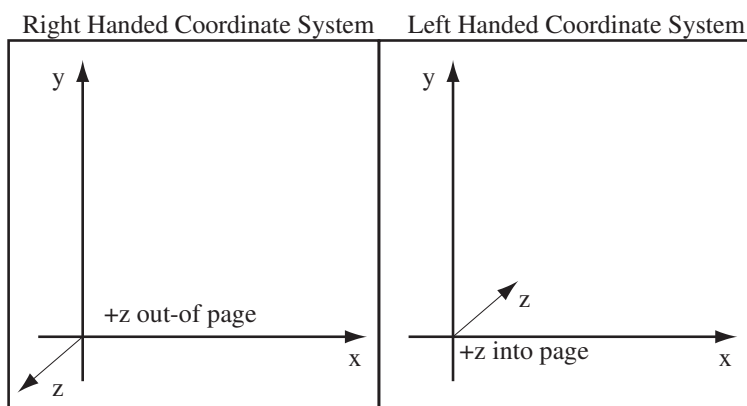

Example 25.4 Selecting Right Handed Coordinate System

Problem: You draw a coordinate system with $+\hat{x}$ pointing to the right on the page and $+\hat{z}$ pointing to the bottom of the page. In what direction is $+\hat{y}$?

Solution

We have to select a direction for \hat{y} so that $\hat{z} = \hat{x} \times \hat{y}$. If \hat{x} points to the right and \hat{z} points to the bottom of the page, then \hat{y} must point out-of the page. Check this by applying the right hand rule to $\hat{x} \times \hat{y}$.

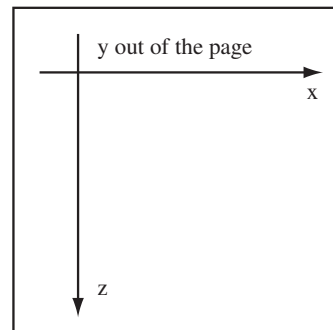

When I do a cross-product, I draw a right-handed coordinate system and use it to work out the results of crossing various combinations of unit vector.

Example 25.5 Dr. Stewart's Cross-Product Method

Problem: The vector $\vec{A} = (2, 0, 3) = 2\hat{x} + 3\hat{z}$ is crossed with the vector $\vec{B} = (4, 3, 0) = 4\hat{x} + 3\hat{y}$. Calculate the cross-product $\vec{C} = \vec{A} \times \vec{B}$.

Solution

(a) Draw a Right-Handed Coordinate System: Use the definition of a right-handed coordinate system, $\hat{z} = \hat{x} \times \hat{y}$, to select the correct direction for the z -axis.

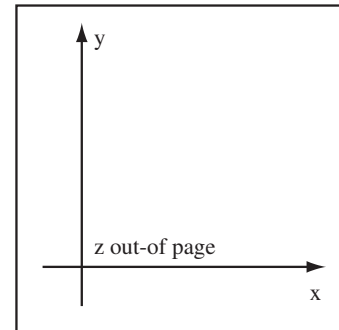

(b) Multiply Out Cross-Product:

$$\vec{C} = \vec{A} \times \vec{B} = (2\hat{x} + 3\hat{z}) \times (4\hat{x} + 3\hat{y})$$

Multiply out the cross-product without changing the order of the terms.

$$\vec{C} = (8\hat{x} \times \hat{x} + 9\hat{z} \times \hat{y} + 12\hat{z} \times \hat{x} + 6\hat{x} \times \hat{y})$$

Since the angle between a vector and itself is zero, a vector crossed with itself is zero, so $\hat{x} \times \hat{x} = 0$. To do the other cross-products, use the right hand rule on the coordinate system drawn above, $\hat{x} \times \hat{y} = \hat{z}$, $\hat{z} \times \hat{y} = -\hat{x}$, and $\hat{z} \times \hat{x} = \hat{y}$.

$$\vec{C} = -9\hat{x} + 12\hat{y} + 6\hat{z}$$

25.2.2 Introduction to Magnetostatics

Electricity and magnetism is such a large subject that the only way to digest it is in bits. We started with electrostatics to keep things simple at first. Electrostatics means that the charges are stationary, and that's why we had only electric fields to consider (no motion—no \vec{B} fields). Traditionally we start studying magnetic fields with *magnetostatics*, too, to keep things simple at first. But this sounds like a contradiction—how can we have statics when \vec{B} requires charges in motion?

By magnetostatics we don't mean that charges aren't moving. We mean that the charge distributions are not changing with time. This can happen even when charges are in motion, provided every charge has a neighboring charge that moves over to take its place right away. Here's an example: a very large number of charges flow continuously around a circular loop of wire (this is indeed physically possible if the wire is a superconductor). Another example is a lit flashlight. The battery drives a constant electric current through the bulb. In both cases, charges are moving, but the charge distribution is maintained, since the charges simply follow each other around the path. (I am thinking of a very large number of charges following each other very closely, so that the flow looks smooth and continuous.)

Definition of the Magnetic Field: The magnetic field, \vec{B} , is a vector field produced by moving charges.

Units of the Magnetic Field: The units of the magnetic field are the Tesla(T).

$$1\text{T} = 1 \frac{\text{Ns}}{\text{Cm}}$$

The unit Gauss (G) is also used for magnetic fields. It must be converted to Tesla before any calculations are performed.

$$1\text{G} = 1 \times 10^{-4}\text{T}$$

Permeability of Free Space: The permeability of free space, μ_0 , (pronounced “mew naught”) is a new fundamental constant of the universe.

$$\mu_0 = 4\pi \times 10^{-7} \frac{\text{Tm}}{\text{A}}$$

The strength of the magnetic field is set by μ_0 .

25.2.3 Biot-Savart Law

There is only charge and field. Since the beginning of the class, we have worked with charge and electric field—first with stationary charge, then with charge moving as constant current in DC circuits, and finally as charge moving in variable currents in RC circuits. In this section, the basic law governing the relation between the magnetic field and moving charge is presented. The law will be presented in two forms; first for an isolated moving charge, then for a current of charges moving in a wire.

Stationary Charges Produce NO Magnetic Field: Every moving charge in the universe produces a magnetic field. An unmoving or stationary charge does not produce a magnetic field.

Biot-Savart Law (Particle Form): The magnetic field, \vec{B}_0 , produced by a particle of charge q moving with velocity \vec{v} is

$$\vec{B}_0 = \frac{\mu_0}{4\pi} \frac{q\vec{v} \times \hat{r}_{10}}{r_{10}^2}$$

where \vec{r}_{10} is the vector from the location of the charge to the location where the field is calculated, and $\mu_0 = 4\pi \times 10^{-7} \frac{\text{Tm}}{\text{A}}$. This formula is an approximation valid for particle speeds that are small compared to the speed of light.

Example 25.6 Magnetic Field of Moving Electron

Problem: An electron is shot in the $-\hat{y}$ direction along the y axis at 0.1% the speed of light. What is the magnetic field at $(10\text{cm}, 0, 0)$ when it reaches the origin?

Solution

Definitions

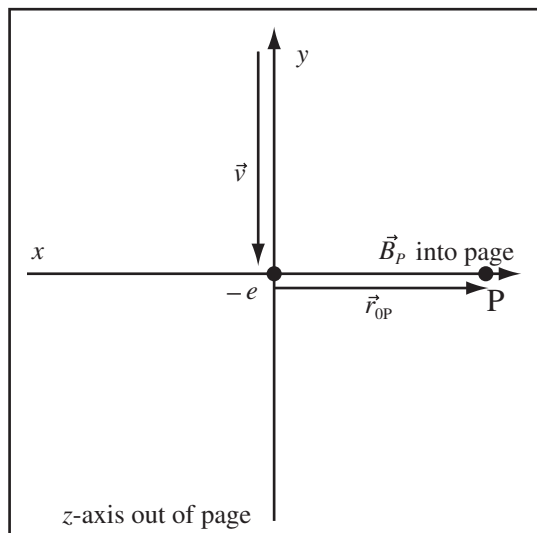

$$\vec{r}_{0P} = (10\text{cm}, 0, 0) \equiv \text{Vector Pointing from Electron at Origin}$$

$$-q = 1.609 \times 10^{-19}\text{C} \equiv \text{Charge of Electron}$$

$$\vec{v} = -0.001c\hat{y} \equiv \text{Velocity of Electron}$$

$$\vec{B}_P \equiv \text{Magnetic Field at } P$$

Strategy: Use Biot-Savart Law (Particle Form) to compute the magnetic field.

(a) Determine Direction of \hat{z} : Use the Right Hand Rule to determine the direction of \hat{z} for a right-handed coordinate system. Point the fingers of your right hand in the direction of \hat{x} and curl the fingers in the \hat{y} direction, which causes your thumb to point out of the page. So for $\hat{x} \times \hat{y} = \hat{z}$, \hat{z} points out of the page.

(b) Use the Magnetic Field of a Moving Particle: Let P be the point where the field is computed. The Biot-Savart Law gives the magnetic field of a moving particle as

$$\vec{B}_{0P} = \left(\frac{\mu_0}{4\pi} \right) \frac{q\vec{v} \times \hat{r}_{0P}}{r_{0P}^2}$$

where \vec{r}_{0P} points from the origin to the point P .

(c) Compute the Magnitude of \vec{B}_{0P} : Since \vec{v} and \hat{r}_{0P} are \perp , the magnitude of $|\vec{v} \times \hat{r}_{0P}| = |\vec{v}||\hat{r}_{0P}| = |\vec{v}|$ and

$$|\vec{B}_P| = \frac{\mu_0 |q| |\vec{v}|}{4\pi r_{0P}^2}$$

(d) Compute Direction of Magnetic Field: First compute the direction of $\vec{v} \times \hat{r}_{0P}$ using the Right Hand Rule. Pointing the fingers of the right hand in the \vec{v} direction and curling the fingers in the \hat{r}_{0P} direction gives the direction of $\vec{v} \times \hat{r}_{0P}$ out of the page. Since $q < 0$, \vec{B}_P is into the page in the $-\hat{z}$ direction.

(e) Substitute and Compute:

$$|\vec{B}_P| = \frac{(4\pi \times 10^{-7} \frac{\text{Tm}}{\text{A}})(1.609 \times 10^{-19} \text{C})(0.001)(3 \times 10^8 \frac{\text{m}}{\text{s}})}{4\pi(0.1\text{m})^2} = 4.827 \times 10^{-19} \text{T}$$

Combine this with the direction of the field to write the magnetic field as a vector

$$\vec{B}_P = -4.827 \times 10^{-19} \text{T} \hat{z}$$

In physics, we routinely deal with charge moving through space, but in everyday life, most of the magnetic fields we work with are generated by currents flowing in wires. The reformulated expression for the magnetic field due to a current is called the Biot-Savart law. There is a subtlety though, a current is continuous (Kirchhoff's Junction Law), so it really does not make sense to talk of an isolated current at a point. We therefore express the Biot-Savart law in terms of the infinitesimal magnetic field $d\vec{B}$ generated by an infinitesimal element of current $I d\vec{\ell}$ where the current, I , flows in the direction $\vec{\ell}$ and the field is generated by a segment of length $d\ell$ of the current.

Biot-Savart Law: The magnetic field $d\vec{B}_0$ produced by the current element $I d\vec{\ell}$ is

$$d\vec{B}_0 = \frac{\mu_0}{4\pi} \frac{I d\vec{\ell} \times \hat{r}_{10}}{r_{10}^2}$$

where \vec{r}_{10} is the vector from the current element to the location where the field is computed, and $\mu_0 = 4\pi \times 10^{-7} \frac{\text{Tm}}{\text{A}}$. This is the fundamental starting point for computing the magnetic field of any current distribution. We imagine the distribution as a collection of current elements, use the Biot-Savart law to find the field contributed by each current element, then sum all the contributions to get the total net field.

Biot-Savart Law - Magnitude Only: The magnitude of the magnetic field $|d\vec{B}_0|$ produced by the current element $I d\vec{\ell}$ is

$$dB_0 = \frac{\mu_0}{4\pi} \frac{I |d\vec{\ell} \times \hat{r}_{10}|}{r_{10}^2} = \frac{\mu_0}{4\pi} \frac{I d\ell \sin \theta}{r_{10}^2}$$

where \vec{r}_{10} is the vector from the current element to the location where the field is computed and θ is the angle between $d\vec{\ell}$ and \vec{r}_{10} and the angle is measured from $d\vec{\ell}$ to \vec{r}_{10} .

Definition of Current Element: Think of a current element $I d\vec{\ell}$ as a tiny bit of a wire carrying electric current I . $d\ell$ is the length of the bit of wire, and $d\vec{\ell}$ points along the wire in the direction of current flow. We will need to imagine current-carrying conductors as collections of current elements in order to apply the principle of linear superposition in computing the magnetic field.

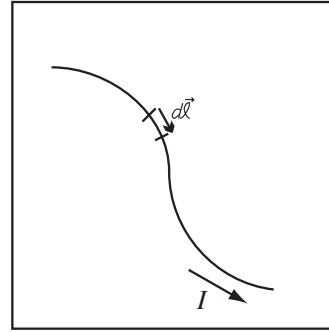

25.2.4 Representing Magnetic Fields at Right Angles to the Page

When drawing electric fields, the field maps showed a side view of the field. Because of the cross product in the definition of the magnetic field, the field is at right angles to the source of the field. It is sometimes useful to draw the end view of a field.

Representing a Third Dimension on a Two-Dimensional Drawing : Represent a vector going into the page as a circle with a cross inside and a vector pointing out of the page as a circle with a dot in it. This is supposed to represent whether the arrow is coming toward you (arrow head = circle/dot) or going away from you (arrow tail = circle/cross). The cross is supposed to represent the feathers on the arrow. This is also used to represent a current flowing into or out of the page.

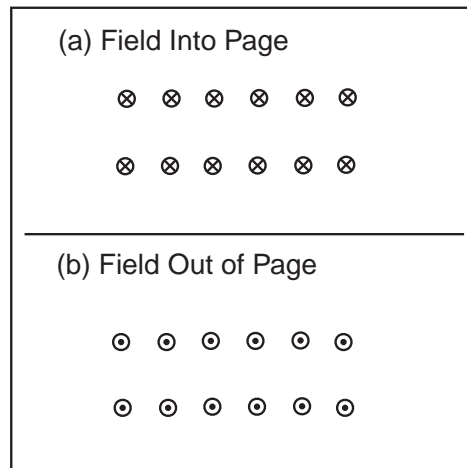

Representing Magnitude of Field Into or Out of Paper: There are two ways to represent the strength of the field into or out of the paper. The magnetic field is stronger where arrows are closer, so a stronger field can be represented by arrows spaced closer together. We will also sometimes ask for the magnetic field at isolated points, in this case the spacing of the arrow heads/tails does not mean anything. Use larger or smaller circles to represent relative magnitudes in this case.

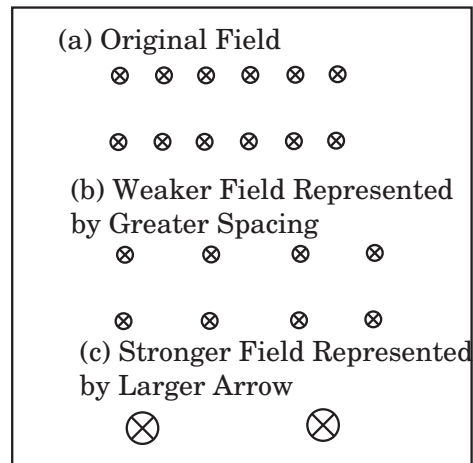

We can use this notation to show the z axis direction in a right-handed coordinate system. The figure to the right shows a right-handed coordinate system.

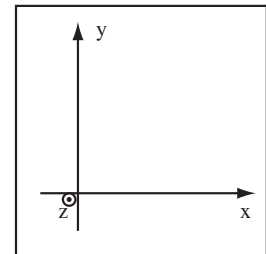

25.3 Simple Current Distributions

25.3.1 Understanding the Difference Between Important Magnetic Fields

You'll note that no example of the computation of a magnetic field from the Biot-Savart law was given earlier. This is because the law involves an infinitesimal current element which must be integrated to produce a finite field. To become familiar with the magnetic field, we will select a few important current distributions and try to understand their fields. The formula for the magnetic fields we present can either be found by integrating the Biot-Savart law (next chapter) or applying Ampere's Law (two chapters down the line). The first two systems, the infinite straight wire and the finite current element, are different limits in the calculation of any circuit. If the point where the field is computed is very near to the wire, the magnetic field will be that of an infinite straight wire. If the field point is very far from a straight wire, all the current appears to be at the same point and the system can be approximated with a finite current element, $I\Delta\ell$ where $\Delta\ell$ is the total length of the wire. The third system is the infinite solenoid, because it produces a uniform field in its interior.

25.3.2 Magnetic Field of Infinite Wire

Magnetic Field of an Infinite Wire Segment: The magnitude of the magnetic field of an infinite straight wire is

$$B = \frac{\mu_0 I}{2\pi R}$$

where I is the current and R is the distance out from the wire. The direction of the field is along a circle concentric with the wire. The direction along the circle is given by the Right Hand Rule for a Wire.

Right Hand Rule for Wire: Grab the wire with your right hand with your thumb pointing along the wire in the direction that the current is flowing. Then, the direction your fingers curl around the wire tells you the direction of the field. Know this one cold!!!!

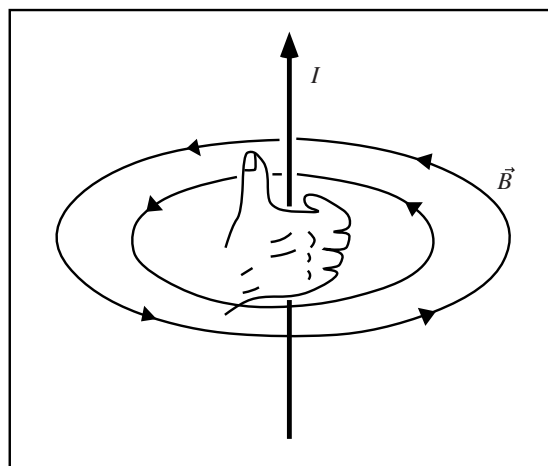

The figure below shows the magnetic field of an infinite straight wire viewed from the end and viewed from the side.

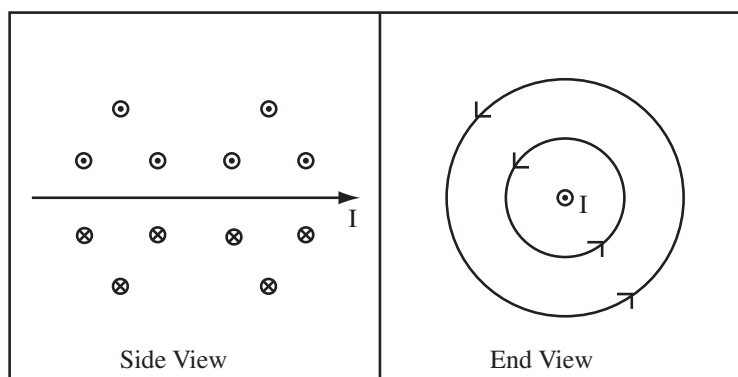

Example 25.7 Magnetic Field of a Current Carrying Wire

Problem: An infinite straight wire runs down the z axis carrying a current of $3A$ in the $+z$ direction. Compute the magnetic field at the point P at $10\text{cm}\hat{x}$

Solution

(a) Compute the Direction: Let the direction z be upward and x to the right. For a right handed coordinate system, y must be into the page so that $\hat{z} = \hat{x} \times \hat{y}$ as drawn to the right. Use the right hand rule for a wire. Imagine grabbing the wire with your right hand so that your fingers curl around the wire and your thumb points in the direction of the current. Your fingers curl in the direction of the field. At point P, your fingers point into the page, so the magnetic field is into the page in the $+y$ direction.

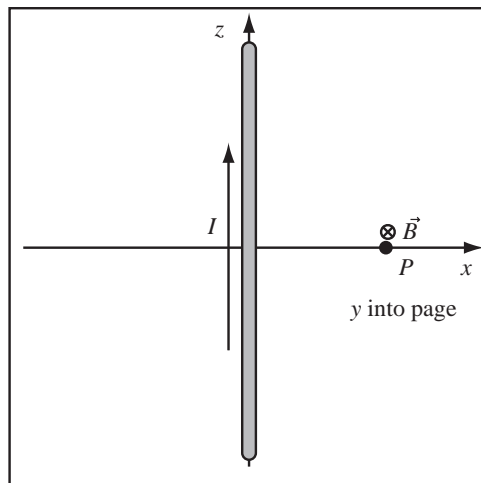

(b) Compute the Magnitude: The magnitude of the magnetic field is given by the formula for the magnetic field of an infinite wire,

$$|B| = \frac{\mu_0 I}{2\pi R}$$

where R is the distance from the wire.

$$|B| = \frac{(4\pi \times 10^{-7} \frac{\text{Tm}}{\text{A}})(3\text{A})}{2\pi(0.1\text{m})} = 6 \times 10^{-6} \text{T}$$

Therefore, the full magnetic field is

$$\vec{B} = 6 \times 10^{-6} \text{T} \hat{y}$$

25.3.3 Field of a Finite Current Element

When the distance to the field point is large compared to the length of the current element, we can use the finite current element approximation to the Biot-Savart law.

Definition Finite Current Element: A continuous current, like that flowing in an electrical circuit, can be approximately represented by a set of finite current elements $I\Delta\vec{\ell}$. The vector $\Delta\vec{\ell}$ is a vector with finite length $\Delta\ell$, which is the length of some segment of the current, and points in the direction of the current.

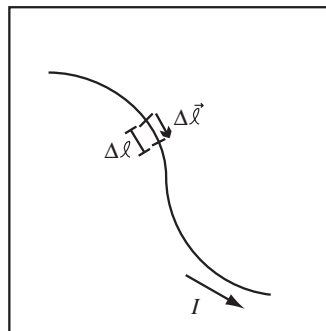

Consider the segment of wire from A to B shown below. The vector $\Delta\vec{\ell}_{AB}$ points in the same direction as the wire and has length the distance between points A and B . As such the vector $\Delta\vec{\ell}_{AB} = \vec{r}_{AB}$ the displacement vector from A to B . So if we have a well-drawn figure, we can just read $\Delta\vec{\ell}$ off the figure. For example, if the large blocks on the figure below represent 1cm then $\Delta\vec{\ell}_{AB} = (2\text{cm}, -2\text{cm}, 0)$.

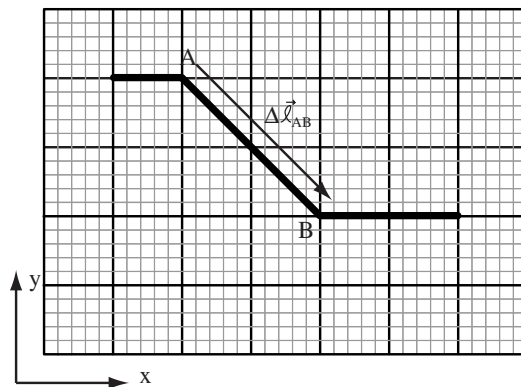

Magnetic Field of a Finite Current Element: The magnetic field \vec{B}_0 produced by the finite current element $I\Delta\vec{l}$ can be approximated by

$$\vec{B}_0 = \frac{\mu_0}{4\pi} \frac{I\Delta\vec{l} \times \hat{r}_{10}}{r_{10}^2} = \frac{\mu_0}{4\pi} \frac{I\Delta\vec{l} \times \vec{r}_{10}}{r_{10}^3}$$

where \vec{r}_{10} is the vector from the center of the current element to the location where the field is computed. The vector $\Delta\vec{l}$ points in the direction of the current and has magnitude ℓ , the length of the current element. The approximation improves as the distance to the field point becomes large compared length of the current element. The second expression uses the definition of the unit vector, $\hat{r}_{10} = \vec{r}_{10}/r_{10}$.

The field of the finite current element is simply the Biot-Savart law before the limit $\Delta\vec{l} \Rightarrow d\vec{l}$ is taken.

Example 25.8 Finite Current Element

Problem: A wire carrying current 0.5A passes through the origin such that the wire is parallel to the z -axis at the origin. The current flows in the positive z direction. Compute the contribution to the magnetic field at the point P (5cm, 0, 5cm) from an element of current of length 1mm at the origin.

Solution

(a) Compute the Magnitude: The displacement vector from the origin to the point (5cm, 0, 5cm) makes an angle of 45° to the current. The displacement vector from the origin to the point P (see figure below) has length

$$r_{0P} = \sqrt{(5\text{cm})^2 + 0 + (5\text{cm})^2} = 5\sqrt{2}\text{cm}$$

The finite current element approximation to the Biot-Savart law is

$$\vec{B}_P = \frac{\mu_0}{4\pi} \frac{I\Delta\vec{l} \times \hat{r}_{0P}}{r_{0P}^2}$$

The current element given is 1mm in length and flows in the $+\hat{z}$ direction.

$$I\Delta\vec{l} = I(1\text{mm})(\hat{z}) = (0.5\text{A})(1 \times 10^{-3})(\hat{z}) = 5 \times 10^{-4} \text{Am}\hat{z}$$

Substitute

$$\vec{B}_P = \frac{\mu_0}{4\pi} \frac{(5 \times 10^{-4} \text{Am}\hat{z}) \times \hat{r}_{0P}}{r_{0P}^2}$$

The magnitude of the cross product is

$$|\hat{z} \times \hat{r}_{0P}| = |\hat{z}||\hat{r}_{0P}| \sin(45^\circ) = \sin(45^\circ) = \frac{1}{\sqrt{2}}$$

where 45° is the angle between \hat{z} and \hat{r}_{0P} . Substitute and compute the magnitude

$$|\vec{B}_P| = \left| \frac{\mu_0 (5 \times 10^{-4} \text{Am})(\hat{z} \times \hat{r}_{0P})}{4\pi (5\sqrt{2}\text{cm})^2} \right| = \frac{(4\pi \times 10^{-7} \frac{\text{Tm}}{\text{A}}) (5 \times 10^{-4} \text{Am})}{4\pi (5\sqrt{2}\text{cm})^2} \frac{1}{\sqrt{2}}$$

$$|\vec{B}_P| = 7.07 \times 10^{-9} \text{T}$$

(b) Compute the Direction: First, draw a right handed coordinate system such that $\hat{z} = \hat{x} \times \hat{y}$. For the choice of the x and z axes to the right, the y -axis points into the page. The direction of the magnetic field is found by the right hand rule. Point the fingers of your right hand in the direction of the current and curl your fingers in the direction of the displacement vector. Your thumb should end up pointing into the page, in the $+y$ direction. Therefore,

$$\vec{B}_P = 7.07 \times 10^{-9} \text{T} \hat{y}$$

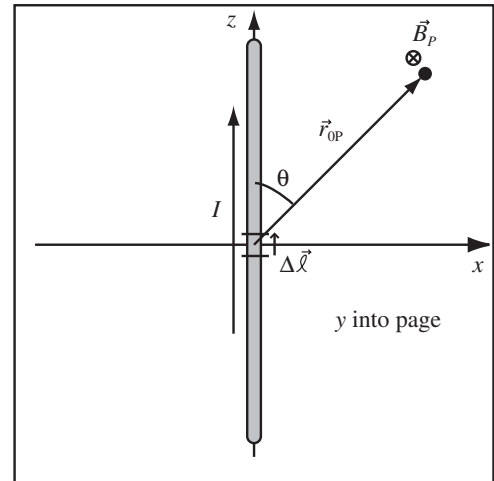

Let's rework the above example by letting the vectors do the work for us.

Example 25.9 Finite Current Element - Part II

Problem: A wire carrying current 0.5A passes through the origin such that the wire is parallel to the z -axis at the origin. The current flows in the positive z direction. Compute the contribution to the magnetic field at the point $P (5\text{cm}, 0, 5\text{cm})$ from an element of current of length 1mm at the origin.

Solution

(a) Compute the Displacement Vector: The displacement vector points from the origin to the point $(5\text{cm}, 0, 5\text{cm})$, therefore $\vec{r}_{0P} = (5\text{cm}, 0, 5\text{cm})$. The length of the displacement vector is

$$r_{0P} = \sqrt{(5\text{cm})^2 + (5\text{cm})^2} = 5\sqrt{2}\text{cm}$$

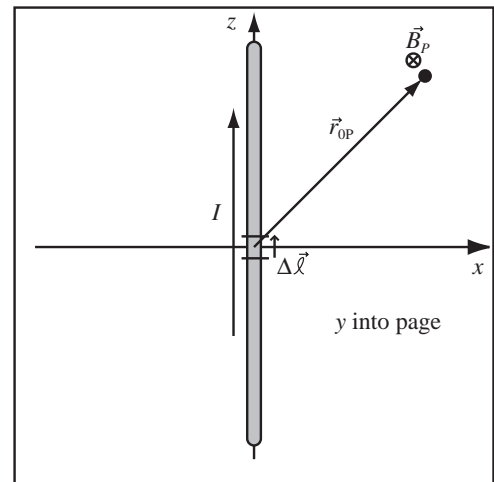

(b) Compute the Current Element: The path element given is $\Delta\ell = 1\text{mm}$ in length and flows in the $+\hat{z}$ direction, $I\Delta\vec{\ell} = I\Delta\ell\hat{z}$

(c) **Compute the Field:** The finite current element approximation to the Biot-Savart law is

$$\vec{B}_P = \frac{\mu_0}{4\pi} \frac{I \Delta \vec{\ell} \times \hat{r}_{0P}}{r_{0P}^2} = \frac{\mu_0}{4\pi} \frac{I \Delta \vec{\ell} \times \vec{r}_{0P}}{r_{0P}^3}$$

Substitute

$$\vec{B}_P = \frac{\mu_0}{4\pi} \frac{(I \Delta \ell \hat{z}) \times \vec{r}_{0P}}{r_{0P}^3} = \frac{\mu_0}{4\pi} \frac{((0.5\text{A})(0.001\text{m})\hat{z}) \times (0.05\text{m}\hat{x} + 0.05\text{m}\hat{z})}{(5\sqrt{2} \times 10^{-2}\text{m})^3}$$

$$\vec{B}_P = 7.07 \times 10^{-9}\text{T}(\hat{z} \times (\hat{x} + \hat{z})) = 7.07 \times 10^{-9}\text{T}(\hat{z} \times \hat{x} + \hat{z} \times \hat{z})$$

Therefore,

$$\vec{B}_P = 7.07 \times 10^{-9}\text{T}\hat{y}$$

since $\hat{z} \times \hat{z}$ and $\hat{z} \times \hat{x} = \hat{y}$ which I found using the right-hand-rule on my diagram.

25.3.4 Magnetic Field of an Infinite Solenoid

Our final common field is that of the infinite solenoid. The solenoid is important because it can be used to create much stronger fields than a single wire and the field interior to the solenoid is uniform.

Field of an Infinite Solenoid: The magnetic field inside an infinitely long solenoid wound with n of wire turns per unit length carrying current I is

$$|\vec{B}| = \mu_0 n I$$

The field is uniform and directed along the axis of the solenoid in the following right-handed sense: if you curl the fingers of your right hand to follow the current in the solenoid windings, your right thumb points in the direction of the field inside. Outside of the infinite solenoid, the field is zero. *Avoid a notorious trap*— n is *not* the number of turns of wire wrapped around the solenoid! It's a number of turns divided by the length over which they are wrapped along the solenoid cylinder.

$$n = \frac{N}{L}$$

where N is the number of wraps and L is the length.

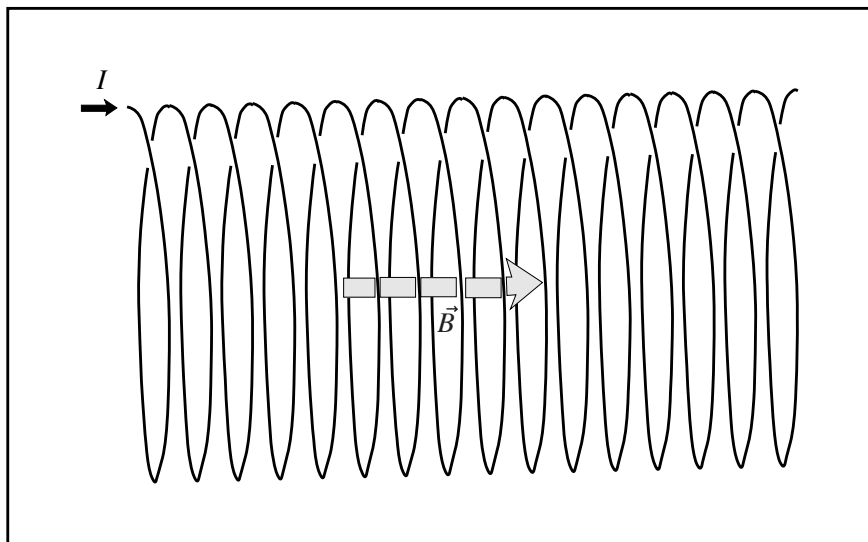

It is a pain drawing all those curves and it is also difficult to determine direction of the field. I will represent a solenoid by the cut-away drawing shown below where the current direction is clearly shown. If you don't want to use the right-hand rule given above (and I don't), the direction of the field can be found by using the right-hand-rule for a wire on any of the loops. The field is uniform inside and zero outside. I have drawn the field of one of the individual loops as a dashed line. The direction of the field of one of the loops, inside the solenoid, is the same as the direction of the solenoid's field.

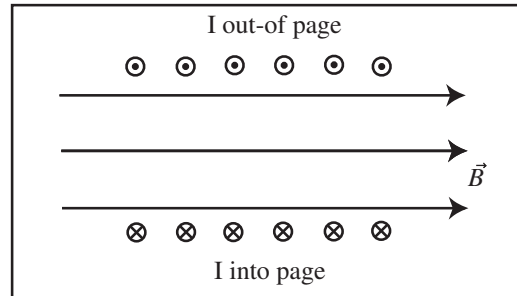

Example 25.10 Magnetic Field of an Infinite Solenoid

Problem: You wind a solenoid on a paper towel tube of length 30cm using 500 wraps of wire.

- (a) Compute the magnetic field in the solenoid if the solenoid carried 0.5A.
 (b) How much current would you have to run through your homemade solenoid to produce a 1T magnetic field (yes, it would burn up)?

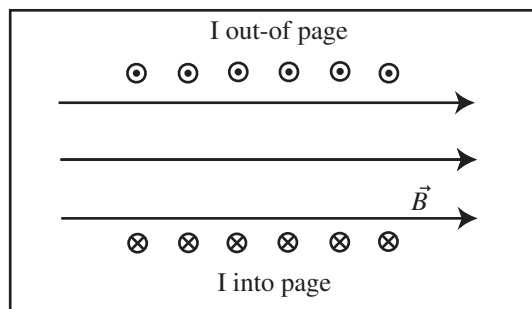

Definitions

- $N = 500\text{turns} \equiv$ Number of turns
 $L = 30\text{cm} \equiv$ Length of solenoid
 $n = N/\ell \equiv$ Turns per unit length of solenoid
 $I \equiv$ Current in solenoid
 $B \equiv$ Magnitude of Field in Solenoid
 $r = 1.5\text{cm} \equiv$ Radius of Solenoid
 $I_C \equiv$ Total Current Enclosed

Solution to Part(a)

The magnitude of the magnetic field of an infinite straight solenoid is

$$B = n\mu_0 I = \frac{N}{L}\mu_0 I$$

where n is the turns per unit length, N is the total number of turns of wire, and L is the length of the solenoid. If the solenoid carries 0.5A and has length $L = 30\text{cm}$ and is wound with a total of $N = 500\text{turns}$ of wire, then

$$B = \frac{500\text{turns}}{30\text{cm}}(4\pi \times 10^{-7} \frac{\text{Tm}}{\text{A}})(0.5\text{A}) = 1.05 \times 10^{-3}\text{T}$$

Solution to Part(b)

Solve the expression for B for the current and substitute 1T for the magnetic field,

$$I = \frac{BL}{N\mu_0} = \frac{(1\text{T})(0.30\text{m})}{(500\text{turns})(4\pi \times 10^{-7} \frac{\text{Tm}}{\text{A}})} = 477\text{A}$$

25.4 Drawing the Magnetic Field

This section takes you through the process of drawing magnetic field maps for system of wires and systems of permanent magnets. There is an additional feature to these field maps resulting from the non-existence of magnetic charge.

Magnetic Field Lines Are Closed Curves: Since there is no magnetic charge, magnetic field lines are closed curves. Recall that field lines begin and end on charge and there is no magnetic charge.

The best way to learn to draw a magnetic field map is from an example.

Example 25.11 Draw the Magnetic Field Lines for Two Parallel Currents

Problem: Two wires are parallel and carry currents of equal magnitude in the same direction. Draw the field map for this situation.

Solution

(a) Draw Magnetic Field Lines of Individual Wires: The right-hand rule gives clockwise orientation of magnetic fields for each wire. There should be the same number of magnetic field lines for each wire, since they each have the same current.

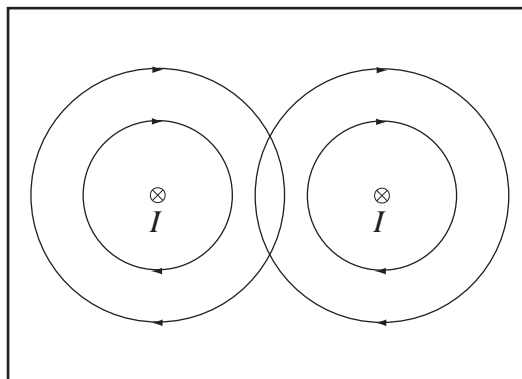

(b) Connect Crossing Lines of Same Orientation: Where field lines intersect and have the same clockwise or counterclockwise orientation connect the lines, erase the portion where the lines go in opposite directions and smooth the result. Work from the outside in until no lines cross.

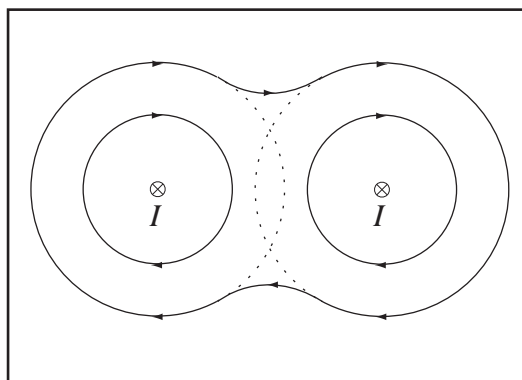

(c) The Completed Magnetic Field Map:

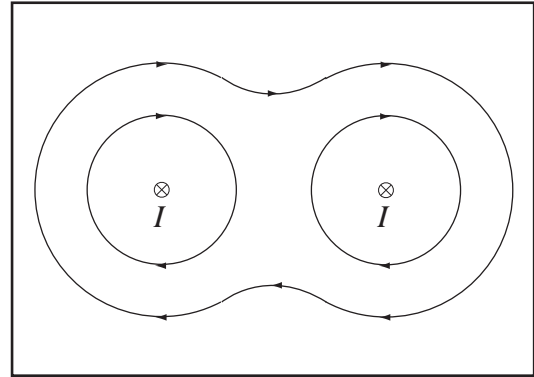

Example 25.12 Draw the Magnetic Field Lines for Two Anti-Parallel Currents.

Problem: Two wires are parallel and carry currents of equal magnitude in opposite directions. Draw the field map for this situation.

Solution

(a) Draw Magnetic Field Lines of Individual Wires: The right-hand rule gives clockwise orientation of the magnetic field for one wire and counterclockwise for the other. There should be the same number of magnetic field lines for each wire since they each have the same magnitude of current. The symbol \otimes represents current into the page and the symbol \odot current out of the page.

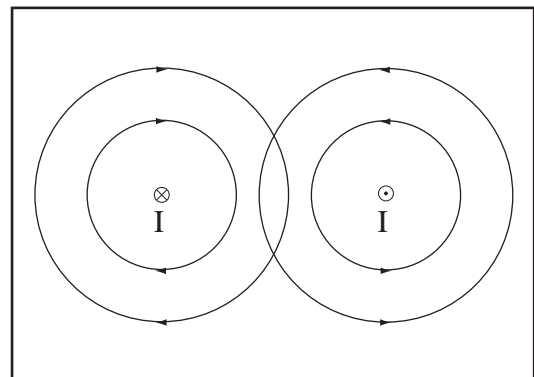

(b) Bend Crossing Lines of Opposite Orientation Apart: Magnetic field lines cannot intersect as drawn above. Where lines of opposite clockwise or counterclockwise orientation intersect, bend the lines so that they no longer intersect.

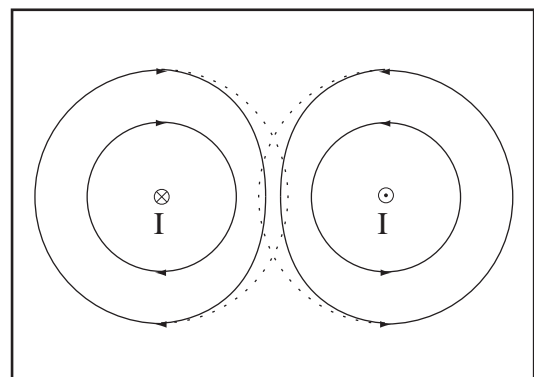

(c) The Completed Magnetic Field Map:

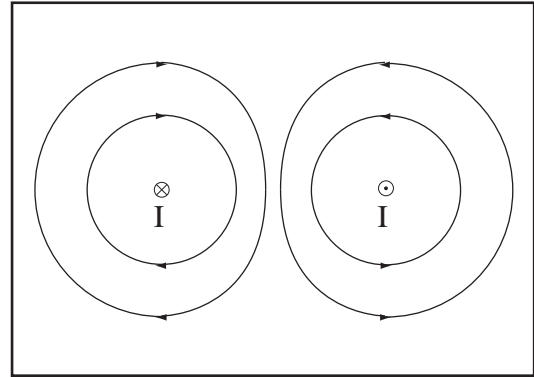

Example 25.13 Draw the Magnetic Field Lines Inside, Outside, and Near the Ends of a Solenoid.

Problem: A number of loops are tightly wound to create a long solenoid. Draw the magnetic field lines inside, outside, and near the ends of the solenoid. Use one line per wire.

Solution

(a) Draw Magnetic Field Lines of Individual Wires: The right-hand rule gives clockwise orientation of the magnetic field for the bottom wires and counterclockwise for the top wires. (\otimes = Current into the page, \odot = Current out of the page)

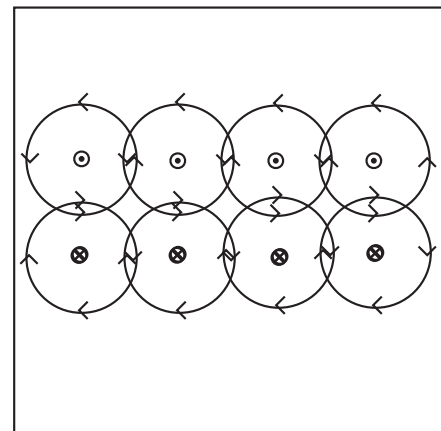

(b) Sum the Magnetic Fields Far Inside and Outside: Using our technique for infinite wires, bend loops of opposite orientation apart and combine loops of the same orientation.

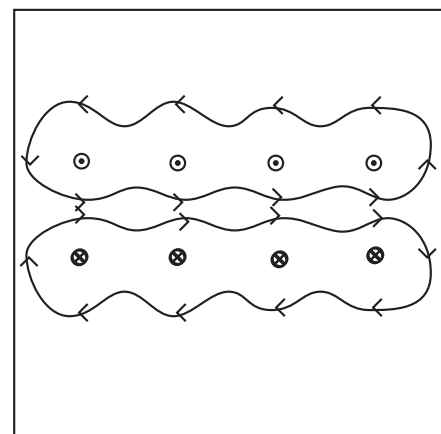

(c) Reason About the Strength of the Field: The field above and below the solenoid partially cancels. It is weaker than the field inside, so push the lines outside the solenoid farther from the solenoid. We would have seen the cancellation if we had included more lines.

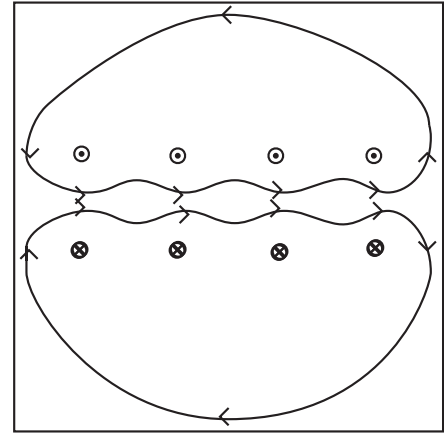

Chapter 26

Computing Magnetic Fields

26.1 Adding Magnetic Fields

Last chapter, we became familiar with the Biot-Savart law and some important magnetic fields. Magnetic fields add by linear superposition in the same way that electric fields do. To compute the magnetic field at point P of a complex system of currents, compute the magnetic field of each current at point P and add the fields vectorially.

Linear Superposition of Magnetic Fields: The magnetic field at some point in space can be found by adding the magnetic fields contributed at that point by each individual moving charge.

Example 26.1 Magnetic Field of House Wiring

Problem: House wiring carries a maximum current of 20A. The two conductors in house wiring are about 1/2cm apart. Model this system as two infinite straight conductors parallel to the y -axis. Let one conductor carry 20A in the $+\hat{y}$ direction through the point $x = 0.25\text{cm}$ on the x -axis. Let the other conductor carry 20A in the $-\hat{y}$ direction through the point $x = -0.25\text{cm}$ on the x -axis.

- Compute the magnetic field, \vec{B}_+ , due to the conductor at $x = +0.25\text{cm}$ at a point P at 2cm along the x -axis.
- Compute the magnetic field, \vec{B}_- , due to the conductor at $x = -0.25\text{cm}$ at a point P at 2cm along the x -axis.
- Compute the total field, \vec{B}_P , at point P .

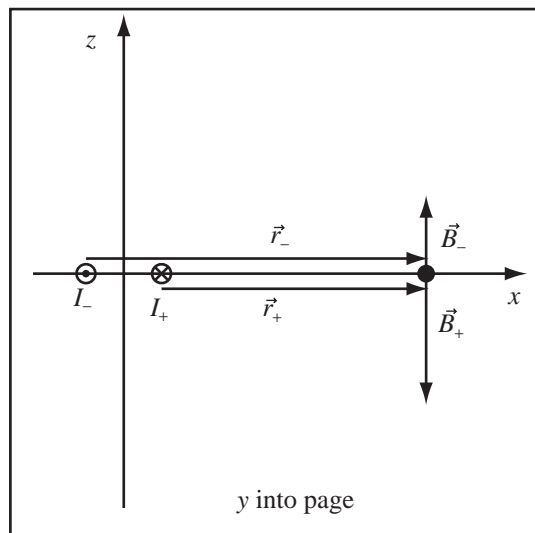

Definitions

$\vec{B}_i \equiv$ Magnetic Field due to Wire i

$I_i \equiv$ Current i

$r_i \equiv$ Distance From Wire to Field Point

Strategy: Compute the magnetic field of each wire; then, add, using linear superposition.

Solution to Part (a)

(a) Select Right Handed Coordinate System: For $\hat{x} \times \hat{y} = \hat{z}$, $+\hat{y}$ must be into the page, therefore the currents are as drawn.

(b) Use the Right Hand Rule for a Wire to Compute the Fields: The field lines of an infinite wire form circles around the wire. Use the right hand rule for a wire for I_+ which flows into the page. Imagine grabbing the wire with your right hand, with your thumb pointing in the direction of the current. Your fingers curl in the direction of the magnetic field, which for I_+ gives a clockwise field. This field points down at the point P where we wish to compute the magnetic field, so the magnetic field from I_+ points in the $-\hat{z}$ direction. Repeating the reasoning for the I_- current, gives the direction of the magnetic field of the wire carrying current out of the page as $+\hat{z}$ as drawn. B_+ is slightly larger than B_- , because the I_- current is farther away.

(c) Compute \vec{B}_+ : The distance from I_+ to P is $2\text{cm} - 0.25\text{cm} = 1.75\text{cm}$. The magnetic field of an infinite straight wire is

$$B_+ = \frac{\mu_0 I}{2\pi r_+} = \frac{(4\pi \times 10^{-7} \frac{\text{Tm}}{\text{A}})(20\text{A})}{2\pi(0.0175\text{m})} = 2.29 \times 10^{-4}\text{T}$$

$$\vec{B}_+ = -2.29 \times 10^{-4}\text{T}\hat{z}$$

Solution to Part (b)

Compute \vec{B}_- : The distance from I_- to P is $2\text{cm} + 0.25\text{cm} = 2.25\text{cm}$. The magnetic field of an infinite straight wire is

$$B_- = \frac{\mu_0 I}{2\pi r_-} = \frac{(4\pi \times 10^{-7} \frac{\text{Tm}}{\text{A}})(20\text{A})}{2\pi(0.0225\text{m})} = 1.78 \times 10^{-4}\text{T}$$

$$\vec{B}_- = 1.78 \times 10^{-4}\text{T}\hat{z}$$

Solution to Part (c)

Compute the Total Field: By linear superposition, the total field due to the two wires at point P is

$$\vec{B}_P = \vec{B}_+ + \vec{B}_- = -2.29 \times 10^{-4}\text{T}\hat{z} + 1.78 \times 10^{-4}\text{T}\hat{z} = -0.51 \times 10^{-4}\text{T}\hat{z}$$

Example 26.2 Magnetic Field of Solenoid and Wire

Problem: An infinite straight wire runs through an infinite solenoid. A side and top view is shown below. Consider the field at point P , a distance $d = 1\text{cm}$ from the infinite straight wire, along the axis of the solenoid. The solenoid has 30 turns of wire over a length of 5cm and a radius of 2cm . The solenoid carries a current of $I_{\text{sol}} = 10\text{mA}$ and the infinite straight wire carries a current of $I = 2\text{A}$.

- (a) On the side view diagram, draw the magnetic field due to the solenoid only.
- (b) At the point P in the top view diagram, draw the magnetic field vector from the solenoid, from the straight wire, and the total magnetic field vector.
- (c) Compute the magnetic field of the solenoid.
- (d) Compute the magnetic field of the straight wire at point P .
- (e) Compute the total magnetic field at point P .

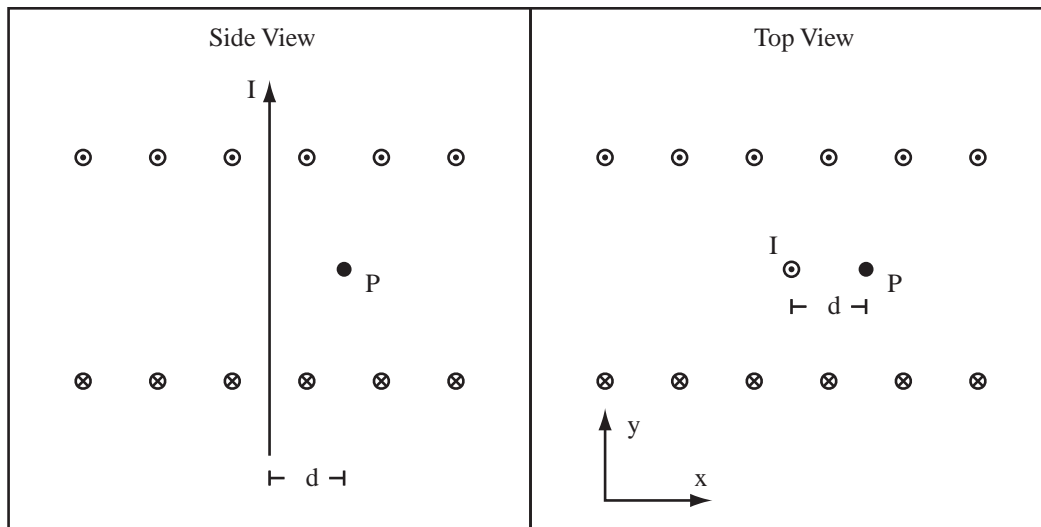

Solution to Part (a)

Use the Right Hand Rule for a Wire on any of the solenoid wires to get the direction of the uniform field in the solenoid.

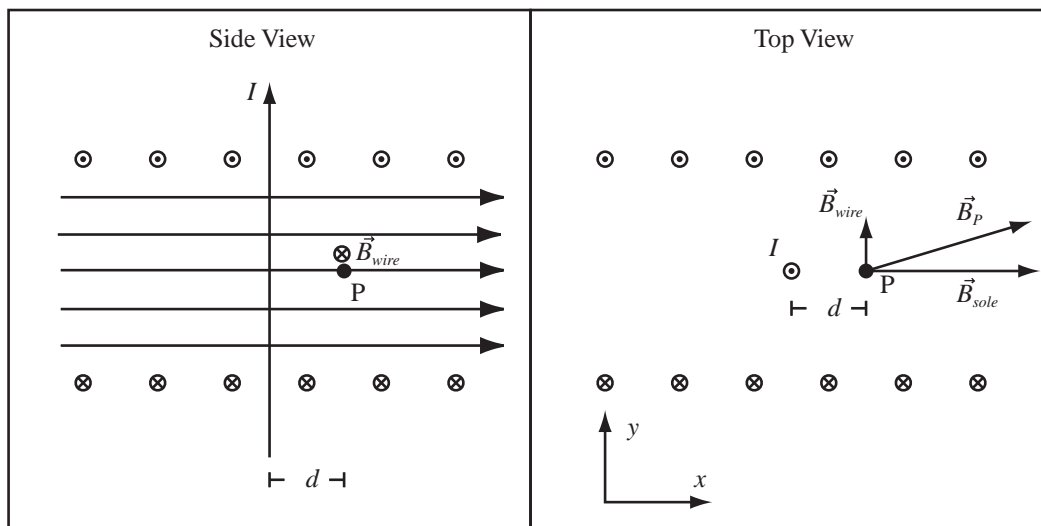

Solution to Part (b)

Use the Right Hand Rule for a Wire to get the field of the wire at point P. The field lines are circles about the current.

Solution to Part (c)

The field of an infinite solenoid is:

$$\begin{aligned}\vec{B}_{sole} &= n\mu_0 I \hat{x} = \left(\frac{30}{0.05\text{m}}\right) \left(4\pi \times 10^{-7} \frac{\text{Tm}}{\text{A}}\right) (0.01\text{A}) \hat{x} \\ &= 7.54 \times 10^{-6} \text{T} \hat{x}.\end{aligned}$$

Solution to Part (d)

The field of an infinite straight wire is:

$$\begin{aligned}\vec{B}_{wire} &= \frac{\mu_0 I}{2\pi r} \hat{y} = \frac{\left(4\pi \times 10^{-7} \frac{\text{Tm}}{\text{A}}\right)(2\text{A})}{2\pi(0.01\text{m})} \\ &= 4 \times 10^{-5} \text{T} \hat{y}.\end{aligned}$$

Solution to Part (e)

The total field is the sum of the fields by Linear Superposition.

$$\begin{aligned}\vec{B}_P &= \vec{B}_{wire} + \vec{B}_{sole} \\ &= 7.54 \times 10^{-6} \text{T} \hat{x} + 4 \times 10^{-5} \text{T} \hat{y}\end{aligned}$$

Example 26.3 Finite Current Segment Approximation

Problem: The wire shown below carries a current of 2A in the direction shown. The magnetic field of the wire at point P is computed using the finite current element approximation. The problem which follows takes you through the completion of the calculation. The finite current segments are numbered 1 - 6.

(a) The total field at point P due to the six segments is

$$\vec{B}_P = \vec{B}_{1P} + \vec{B}_{2P} + \vec{B}_{3P} + \vec{B}_{4P} + \vec{B}_{5P} + \vec{B}_{6P}.$$

What physical principle allows you to add the fields in this manner?

(b) What is the contribution to the total magnetic field at point P , \vec{B}_{1P} , from the segment 1, between points $A \rightarrow B$?

Because of the symmetry of the problem, the total field is

$$\vec{B}_P = 2(\vec{B}_{1P} + \vec{B}_{2P} + \vec{B}_{3P})$$

(c) Write the vector $\Delta\vec{\ell}_2$ for segment $B \rightarrow C$.

(d) Write the vector \vec{r}_{2P} from the center of segment 2, $B \rightarrow C$ to the point P .

(e) Compute the magnetic field at point P , \vec{B}_{2P} , due to segment 2.

(f) Write the vector $\Delta\vec{\ell}_3$ for segment $C \rightarrow D$.

(g) Write the vector \vec{r}_{3P} from the center of segment 3, $C \rightarrow D$ to the point P .

(h) Compute the magnetic field at point P , \vec{B}_{3P} , due to segment 3.

(i) Compute the total magnetic field at point P .

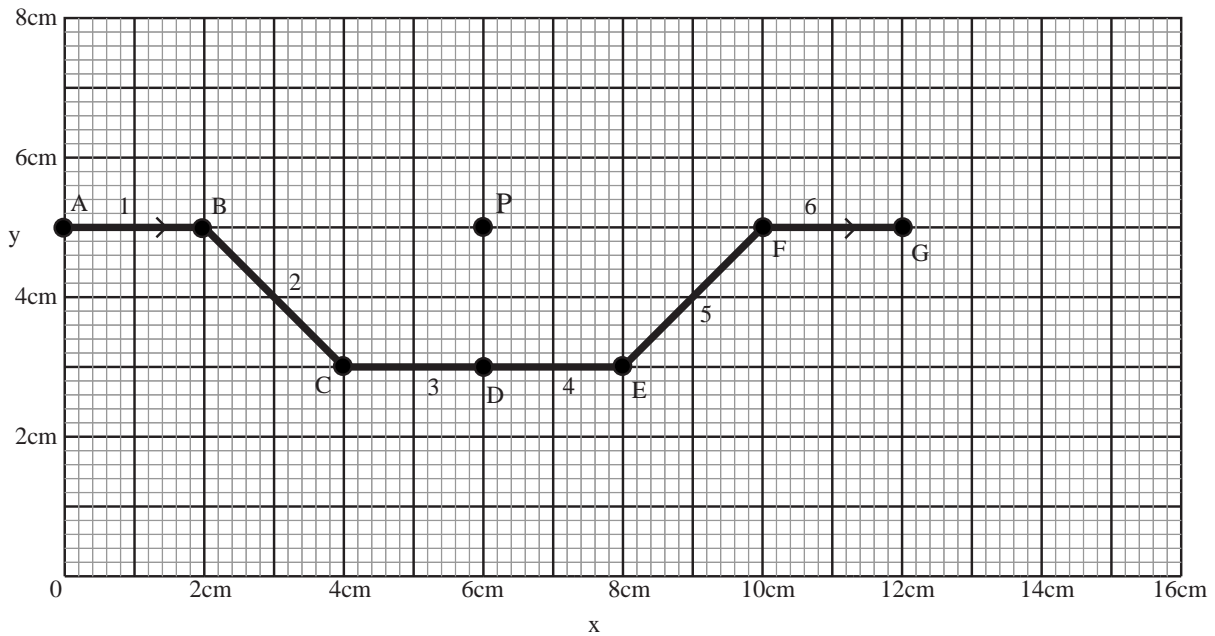

Solution to Part(a)

The magnetic fields of the individual current elements add because of the principle of linear superposition.

Solution to Part(b)

For segment $A \rightarrow B$, the current element $I\Delta\vec{\ell}_1$ is parallel to \hat{r}_{1P} and therefore the field is zero.

Solution to Part(c)

The vectors $\Delta\vec{\ell}_2$, $\Delta\vec{\ell}_3$, \vec{r}_{2P} , and \vec{r}_{3P} are drawn on the figure below and can be read directly from the figure.

$$\Delta\vec{\ell}_2 = (2\text{cm}, -2\text{cm}, 0)$$

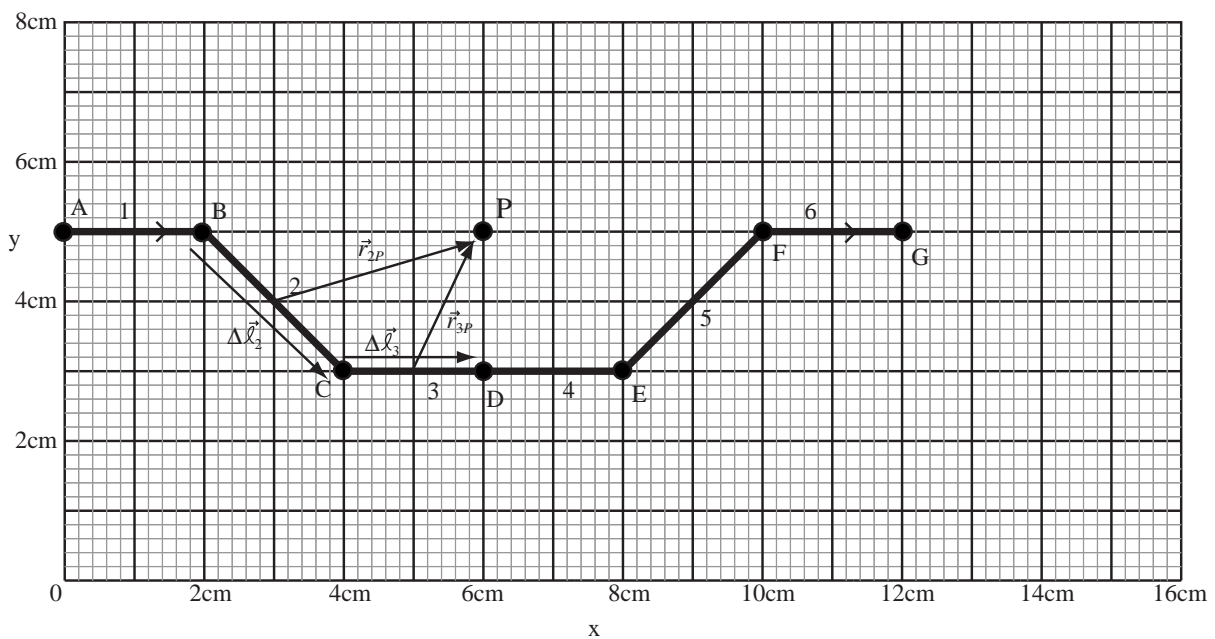

Solution to Part(d)

The vector $\vec{r}_{2P} = (3\text{cm}, 1\text{cm}, 0)$ from the diagram.

Solution to Part(e)

The magnetic field from segment 2 is given by the finite element approximation to the Biot-Savart law,

$$\vec{B}_{2P} = \frac{\mu_0}{4\pi} I \frac{\Delta\vec{\ell}_2 \times \hat{r}_{2P}}{r_{2P}^2}$$

therefore we need \hat{r}_{2P} and the length r_{2P} . The length of the vector is given by $r_{2P} = \sqrt{(3\text{cm})^2 + (1\text{cm})^2} = \sqrt{10}\text{cm}$. The unit vector is by definition

$$\hat{r}_{2P} = \frac{\vec{r}_{2P}}{r_{2P}} = \left(\frac{3}{\sqrt{10}}, \frac{1}{\sqrt{10}}, 0 \right)$$

The expression for the magnetic field requires the calculation of the cross product,

$$\Delta\vec{\ell}_2 \times \hat{r}_{2P} = (2\text{cm}\hat{x} - 2\text{cm}\hat{y}) \times \left(\frac{3}{\sqrt{10}}\hat{x} + \frac{1}{\sqrt{10}}\hat{y} \right) = \frac{2\text{cm}}{\sqrt{10}}(\hat{x} \times \hat{y}) - \frac{6\text{cm}}{\sqrt{10}}(\hat{y} \times \hat{x})$$

Using $\hat{x} \times \hat{y} = \hat{z}$ and $\hat{y} \times \hat{x} = -\hat{z}$, this becomes

$$\Delta\vec{\ell}_2 \times \hat{r}_{2P} = \frac{2\text{cm}}{\sqrt{10}}\hat{z} + \frac{6\text{cm}}{\sqrt{10}}\hat{z} = \frac{8\text{cm}}{\sqrt{10}}\hat{z}$$

Now finish the calculation,

$$\vec{B}_{2P} = \frac{\mu_0}{4\pi} I \frac{\Delta\vec{\ell}_2 \times \hat{r}_{2P}}{r_{2P}^2} = \frac{4\pi \times 10^{-7} \frac{\text{Tm}}{\text{A}}}{4\pi} (2\text{A}) \frac{1}{(\sqrt{10} \times 10^{-2}\text{m})^2} \frac{0.08\text{m}}{\sqrt{10}} \hat{z}$$

$$\vec{B}_{2P} = 5.09 \times 10^{-6} \text{T}\hat{z}$$

Solution to Part(f)

$$\Delta\vec{\ell}_3 = (2\text{cm}, 0, 0)$$

Solution to Part(g)

The vector from the center of segment 3 to the point P is from the diagram $\vec{r}_{3P} = 1\text{cm}\hat{x} + 2\text{cm}\hat{y}$.

Solution to Part(h)

The magnetic field from segment 3 is given by the finite element approximation to the Biot-Savart law,

$$\vec{B}_{3P} = \frac{\mu_0}{4\pi} I \frac{\Delta\vec{\ell}_3 \times \hat{r}_{3P}}{r_{3P}^2}$$

therefore we need \hat{r}_{3P} and the length r_{3P} . The length of the vector is given by $r_{3P} = \sqrt{(1\text{cm})^2 + (2\text{cm})^2} = \sqrt{5}\text{cm}$. The unit vector is by definition

$$\hat{r}_{3P} = \frac{\vec{r}_{3P}}{r_{3P}} = \left(\frac{1}{\sqrt{5}}, \frac{2}{\sqrt{5}}, 0 \right)$$

The expression for the magnetic field requires the calculation of the cross product,

$$\Delta\vec{\ell}_3 \times \hat{r}_{3P} = (2\text{cm}\hat{x}) \times \left(\frac{1}{\sqrt{5}}\hat{x} + \frac{2}{\sqrt{5}}\hat{y} \right) = \frac{4\text{cm}}{\sqrt{5}}(\hat{x} \times \hat{y}) = \frac{4\text{cm}}{\sqrt{5}}\hat{z}$$

Now finish the calculation,

$$\vec{B}_{3P} = \frac{\mu_0}{4\pi} I \frac{\Delta\vec{\ell}_3 \times \hat{r}_{3P}}{r_{3P}^2} = \frac{4\pi \times 10^{-7} \frac{\text{Tm}}{\text{A}}}{4\pi} (2\text{A}) \frac{1}{(\sqrt{5} \times 10^{-2}\text{m})^2} \frac{0.04\text{m}}{\sqrt{5}} \hat{z}$$

$$\vec{B}_{3P} = 7.15 \times 10^{-6} \text{T}\hat{z}$$

Solution to Part(i)

So by linear superposition,

$$\vec{B}_P = 2(0 + 5.06 \times 10^{-6} \text{T}\hat{z} + 7.15 \times 10^{-6} \text{T}\hat{z}) = 24.42 \times 10^{-6} \text{T}\hat{z}$$

26.2 Arbitrary Currents

26.2.1 Finding Total Magnetic Field for Currents Lying in a Plane

The Biot-Savart law is much more complicated than Coulomb's law. However, the actual exact calculation of the magnetic field by integrating the Biot-Savart law over the current will often prove easier than the calculation of electric fields by integrating Coulomb's law. Suppose we have a system where both the current and the point where the field is to be calculated lie in the x - y plane as shown below. The field at the point P or any other point in the plane is in the $\pm z$ direction, because both \vec{r} and $d\vec{\ell}$ are in the plane and the cross-product always returns a vector perpendicular to both vectors that are crossed.

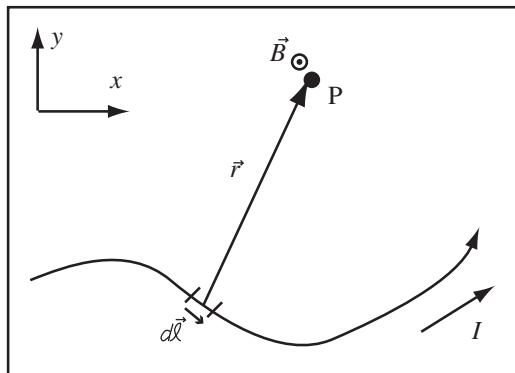

This means rather than working with the full vector expression for the Biot-Savart law, we can work with the magnitude alone, since we already know the direction,

$$dB_0 = \frac{\mu_0}{4\pi} \frac{I d\ell \sin \theta}{r_{10}^2}$$

where θ is measured from $d\vec{\ell}$ to \vec{r} . We do have to be careful of the sign, but this is a lot of progress.

Example 26.4 Compute Magnetic Field of Current-Carrying Wire

Problem: A circle of wire with radius 10cm lying in the $x - y$ plane carries a current $I = 10A$ which flows in the counterclockwise direction when viewed from the $+z$ side of the plane. Compute the magnetic field at the origin.

Solution

Strategy: Imagine dividing the wire into small segments (i.e., current elements), use the Biot-Savart Law on each segment, and then use linear superposition to add up the field contributions of all the segments.

(a) Divide the Wire into Small Segments: Divide the wire into small current elements $I\Delta\vec{\ell}$, where $d\vec{\ell}$ points along the wire in the direction of current flow.

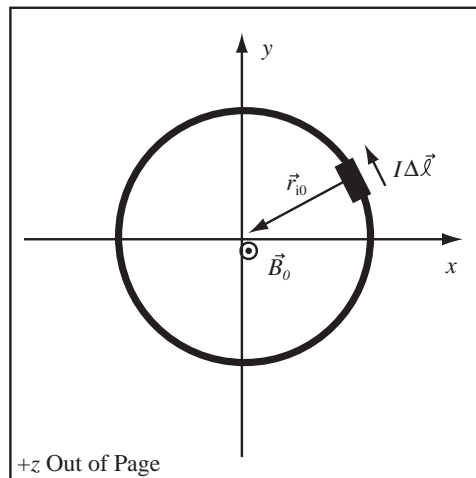

(b) Use Linear Superposition: The total magnetic field can be found by adding the fields of the current elements, \vec{B}_i ,

$$\vec{B}_0 = \sum_i \vec{B}_i.$$

(c) Use Biot-Savart Law: The field produced by the individual segment i is in the $+\hat{z}$ direction by the right-hand-rule. Its magnitude is given by the Biot-Savart Law

$$B_i = \frac{\mu_0}{4\pi} \frac{I\Delta\ell \sin\theta}{r_{i0}^2}$$

where \vec{r}_{i0} is the vector from the current element to the origin and θ is the angle between $\Delta\vec{\ell}$ and \vec{r}_{i0} . The angle between these vectors is always $\theta = 90^\circ$, so $\sin\theta = 1$. The distance from the element i to the origin is $r_{i0} = R$, the radius of the circle. Since the field of each segment points in the $+\hat{z}$ direction,

$$\vec{B}_i = \frac{\mu_0}{4\pi} \frac{I\Delta\ell}{R^2} \hat{z}$$

The total field at the origin is

$$\vec{B}_0 = \left(\sum_i \frac{\mu_0}{4\pi} \frac{I\Delta\ell}{R^2} \right) \hat{z}$$

(d) Write Sum as Integral: Let $\Delta\ell$ become infinitely short.

$$\vec{B}_0 = \left(\int_C \frac{\mu_0}{4\pi} \frac{I d\ell}{R^2} \right) \hat{z} = \left(\frac{\mu_0}{4\pi} \frac{I}{R^2} \int_C d\ell \right) \hat{z}$$

where the integral is taken around the circle C . The integral of an element of the circle around the circle is just the circumference of the circle $\int_C d\ell = 2\pi R$.

$$\vec{B}_0 = \frac{\mu_0}{2} \frac{I}{R} \hat{z}$$

or substituting the numbers given in the problem

$$\vec{B}_0 = 6.283 \times 10^{-5} \text{T} \hat{z}$$

Magnetic Field of Current Loop at the Origin: The magnitude of the magnetic field at the origin of a flat circle of wire of radius R that carries current I is

$$B_0 = \frac{\mu_0}{2} \frac{I}{R}$$

The magnetic field of a finite current element is an approximation to the exact expression for the field of a finite wire. It is accurate in the limit where the distance from the wire is large compared to the length of the segment, which will be the case any time the wire is broken in many segments.

Example 26.5 Magnetic Field of a Short Wire

Problem: A short wire carries current I in the positive x direction. The wire lies along the x axis between the points $x = -L$ and $x = L$. Compute the field at the point P at $\vec{r}_P = (d, R, 0)$.

Solution

(a) Break the system up into small bits: For a right-handed coordinate system $+z$ is out of the page. Using the right-hand-rule and the Biot-Savart law this is also the direction of the magnetic field.

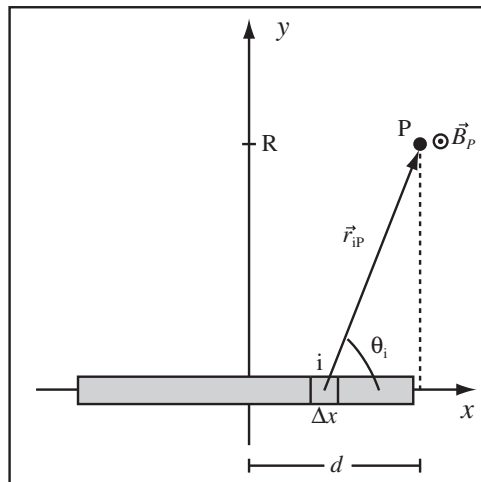

(b) Compute Needed Vectors: The displacement vector from the chunk i to the point P is

$$\vec{r}_{iP} = \vec{r}_P - \vec{r}_i = (d, R, 0) - (x_i, 0, 0) = (d - x_i, R, 0)$$

The length of the displacement vector is

$$r_{iP} = \sqrt{(d - x_i)^2 + R^2}$$

(c) Compute the Angle: The angle between the current and the displacement vector for the i th segment, θ_i , can be expressed as

$$\sin \theta_i = \frac{R}{\sqrt{(d - x_i)^2 + R^2}}$$

I found this by using sine = opposite/hypotenuse on the dashed triangle.

(d) Compute the Field: The total field is the sum of the fields of each segment.

$$B_P = \sum_i B_{iP}$$

The field of each segment is given by the Biot-Savart law restricted to the plane.

$$\begin{aligned} B_P &= \sum_i \frac{\mu_0}{4\pi} \frac{I \Delta x \sin \theta_i}{r_{iP}^2} \\ &= \sum_i \frac{\mu_0}{4\pi} \frac{I \Delta x}{(d - x_i)^2 + R^2} \frac{R}{\sqrt{(d - x_i)^2 + R^2}} = \sum_i \frac{\mu_0}{4\pi} \frac{I \Delta x R}{((d - x_i)^2 + R^2)^{\frac{3}{2}}} \end{aligned}$$

(e) Convert the Sum to an Integral and Hope for the Best:

$$B_P = \int_{-L}^L \frac{\mu_0}{4\pi} \frac{I R dx}{((d - x)^2 + R^2)^{\frac{3}{2}}} = \frac{\mu_0 I R}{4\pi} \int_{-L}^L \frac{dx}{((d - x)^2 + R^2)^{\frac{3}{2}}}$$

Integrals.com gives the integral as

$$\int_{-L}^L \frac{dx}{((d-x)^2 + R^2)^{\frac{3}{2}}} = -\frac{d-x}{R^2 \sqrt{(d-x)^2 + R^2}}$$

$$B_P = \frac{\mu_0 I R}{4\pi} \left(-\frac{d-x}{R^2 \sqrt{(d-x)^2 + R^2}} \right)_{-L}^L = \frac{\mu_0 I}{4\pi R} \left(-\frac{d-L}{\sqrt{(d-L)^2 + R^2}} + \frac{d+L}{\sqrt{(d+L)^2 + R^2}} \right)$$

which is hideous.

With a little trig and a little looking up the right answer, we can re-write the solution to the above problem as the formula that follows.

Magnetic Field of Wire Segment : The magnitude of the magnetic field of a wire segment is

$$B = \frac{\mu_0}{4\pi} \frac{I}{R} (\sin(\theta_1) + \sin(\theta_2))$$

where the terms are defined in the diagram and the direction of the field is given by the Right Hand Rule for a Wire. The distance R is the distance from the wire to the point where the field is calculated.

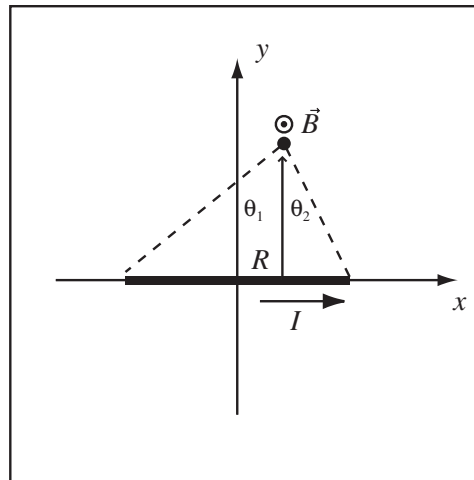

Example 26.6 Field of Short Wire

Problem: A 10cm segment of wire lies along the x -axis with its center at the origin. The wire carries 5A of current. What is the magnitude of the magnetic field at $(5\text{cm}, 5\text{cm}, 0)$? Use the exact result for the field of a finite wire segment.

Solution

Definitions

$R = 5\text{cm} \equiv$ Perpendicular Distance to Wire

$I = 5\text{A} \equiv$ Current in Wire

$\theta_1 \equiv$ Angle shown on figure

$\theta_2 = 0 \equiv$ Other Angle, zero in this problem

$B \equiv$ Magnitude of magnetic field

$d \equiv$ The length of the hypotenuse

$L = 10\text{cm} \equiv$ Length of wire

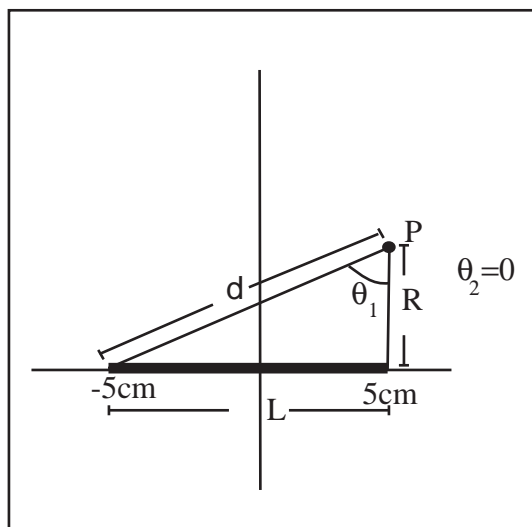

Strategy: Use the formula for the magnetic field of a short wire.

(a) **Use Formula for the Magnetic Field of a Short Wire:** The magnetic field of a short wire is given by

$$B = \frac{\mu_0 I}{4\pi R} \left(\sin \theta_1 + \sin \theta_2 \right)$$

where θ_1 is the angle shown in the figure, $\theta_2 = 0$ because of the geometry of the problem, and R is the perpendicular distance to the wire.

(b) **Compute $\sin \theta_1$:** The $\sin = \frac{o}{h}$ is opposite over hypotenuse. The length of the hypotenuse is $d = \sqrt{R^2 + L^2} = \sqrt{(5\text{cm})^2 + (10\text{cm})^2} = 11.2\text{cm}$. The length of the opposite side is $L = 10\text{cm}$, therefore

$$\sin \theta_1 = \frac{10\text{cm}}{11.2\text{cm}} = 0.893$$

(c) **Substitute and Compute:** Substitute the value for $\sin \theta_1$ into the expression for the magnetic field,

$$B = \frac{\mu_0 I}{4\pi R} \sin \theta_1 = \frac{(4\pi \times 10^{-7} \frac{\text{Tm}}{\text{A}})(5\text{A})}{4\pi(5\text{cm})} (0.893)$$

$$B = 8.9\mu\text{T}$$

Example 26.7 Magnetic Field of Multiple Segments

Problem: The wire below carries 0.3A to the right of the page. The segment AB extends to $-\infty$ and the segment CD extends to $+\infty$. The point B is at $(a, b) = (-1\text{cm}, 0)$ and the point C is at $(0, -2\text{cm})$. The dark lines on the grid below are measured in centimeters.

- Calculate the magnetic field of segment AB at point P exactly.
- Calculate the magnetic field of segment BC at point P in the finite current element approximation.
- Calculate the magnetic field of segment BC at point P exactly.
- Calculate the magnetic field of segment CD at point P in the infinite wire approximation.
- Calculate the magnetic field of segment CD at point P exactly.

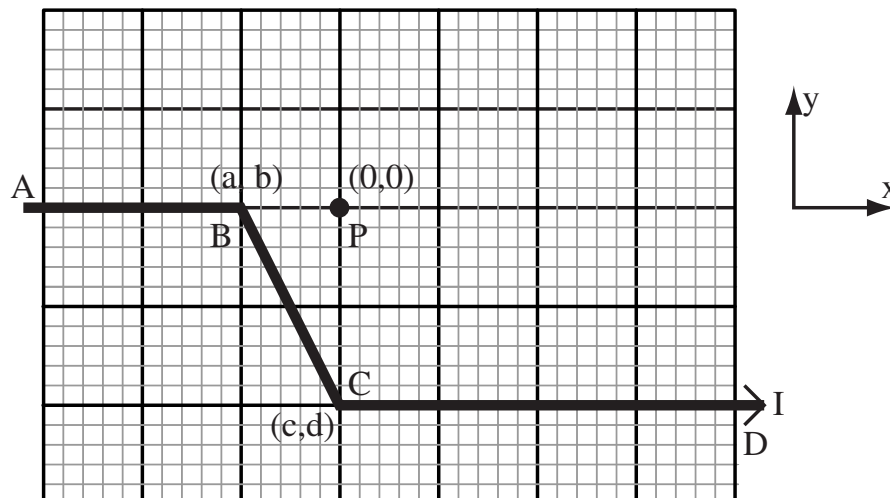

Solution to Part (a)

The displacement vector and current element are parallel for segment AB , so the magnetic field at point P is zero.

Solution to Part (b)

The vector $\Delta\vec{\ell}_{BC}$ points from the point (a, b) to the point (c, d) . This vector is

$$\Delta\vec{\ell}_{BC} = (c - a, d - b) = (1\text{cm}, -2\text{cm})$$

The displacement vector from the center of the segment to the point P is

$$\vec{r}_{BCP} = (0.5\text{cm}, 1\text{cm})$$

The length of this vector is

$$r_{BCP} = \sqrt{(0.5\text{cm})^2 + (1\text{cm})^2} = \sqrt{1.25}\text{cm} = 1.12 \times 10^{-2}\text{m}$$

We will need the cross-product

$$\Delta\vec{\ell}_{BC} \times \vec{r}_{BCP} = (1\text{cm}\hat{x} - 2\text{cm}\hat{y}) \times (0.5\text{cm}\hat{x} + 1\text{cm}\hat{y}) = 1\text{cm}^2\hat{x} \times \hat{y} - 1\text{cm}^2\hat{y} \times \hat{x} = 2\text{cm}^2\hat{z}$$

Use the finite current element approximation to the Biot-Savart Law,

$$\vec{B}_{BCP} = \frac{\mu_0 I}{4\pi} \frac{\Delta\vec{\ell}_{BC} \times \vec{r}_{BCP}}{r_{BCP}^3} = \frac{(4\pi \times 10^{-7} \frac{\text{Tm}}{\text{A}})(0.3\text{A})}{4\pi} \frac{2\text{cm}^2\hat{z}}{(1.12 \times 10^{-2}\text{m})^3} = 4.27 \times 10^{-6}\text{T}\hat{z}$$

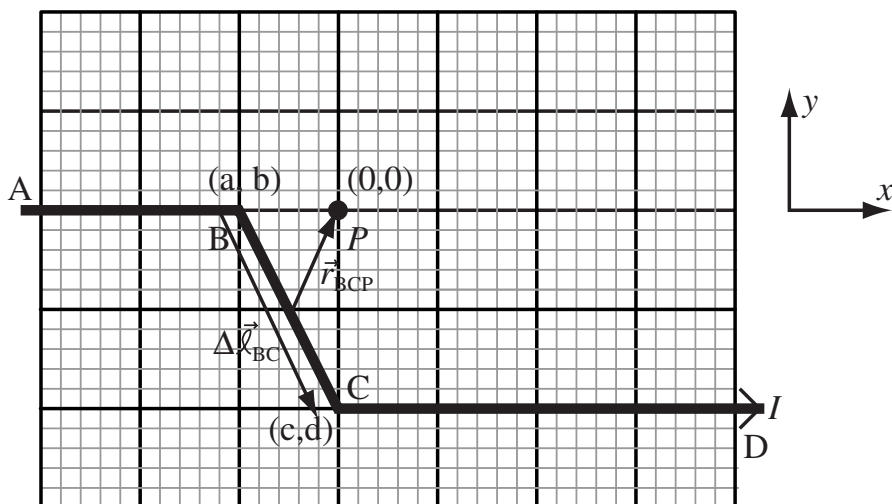

Solution to Part (c)

Divide the segment BC into N small pieces. Let the center of the i th piece be (x_i, y_i) . The line from B to C has the function, $y_i = d - 2x_i$. The displacement vector from the segment i to the point P is

$$\vec{r}_{iP} = (0, 0) - (x_i, y_i) = (-x_i, -y_i) = (-x_i, -d + 2x_i)$$

The length of the displacement vector is

$$r_{iP} = \sqrt{x_i^2 + (-d + 2x_i)^2}$$

If we divide the segment BC into N pieces, then vector $\Delta\vec{\ell}$ for the segment i is $\Delta\vec{\ell} = \Delta\vec{\ell}_{BC}/N$. The distance along the x axis from B to C is $-a$, so $N = -a/\Delta x$, and the

$$\Delta\vec{\ell} = \frac{\Delta\vec{\ell}_{BC}}{N} = \frac{\Delta x \Delta\vec{\ell}_{BC}}{-a} = \Delta x(1, -2)$$

Compute the cross-product,

$$\Delta \vec{\ell} \times \vec{r}_{iP} = \Delta x(1, -2) \times (-x_i, -d + 2x_i) = -d\Delta x \hat{z}$$

The total field at P is the sum of the fields of the segments by linear superposition

$$\vec{B}_{BCP} = \sum_i \vec{B}_{iP}$$

Using the Biot-Savart law for each segment yields

$$\vec{B}_{BCP} = \frac{\mu_0 I}{4\pi} \sum_i \frac{\Delta \vec{\ell} \times \vec{r}_{iP}}{r_{iP}^3} = \frac{\mu_0 I}{4\pi} \sum_i \frac{-d\Delta x \hat{z}}{(\sqrt{x_i^2 + (-d + 2x_i)^2})^3}$$

Convert to an integral

$$\vec{B}_{BCP} = -\frac{d\mu_0 I \hat{z}}{4\pi} \int_a^0 \frac{dx}{(\sqrt{x^2 + (-d + 2x)^2})^3}$$

Integrals.com

$$\begin{aligned} \int \frac{dx}{(\sqrt{x^2 + (-d + 2x)^2})^3} &= \frac{-2d + 5x}{d^2 \sqrt{d^2 - 4dx + 5x^2}} \\ \vec{B}_{BCP} &= -\frac{d\mu_0 I \hat{z}}{4\pi} \left(\frac{-2d + 5x}{d^2 \sqrt{d^2 - 4dx + 5x^2}} \right)_a^0 \\ &= -\frac{d\mu_0 I \hat{z}}{4\pi} \left(\frac{-2}{d^2} - \frac{-2d + 5a}{d^2 \sqrt{d^2 - 4da + 5a^2}} \right) = \frac{\mu_0 I \hat{z}}{4\pi d} \left(2 + \frac{-2d + 5a}{\sqrt{d^2 - 4da + 5a^2}} \right) \end{aligned}$$

Work out the messy bit, $a = -1\text{cm}$ and $d = -2\text{cm}$

$$\frac{-2d + 5a}{\sqrt{d^2 - 4da + 5a^2}} = \frac{-2(-2\text{cm}) + 5(-1\text{cm})}{\sqrt{(-2\text{cm})^2 - 4(-2\text{cm})(-1\text{cm}) + 5(-1\text{cm})^2}} = -1$$

$$\vec{B}_{BCP} = \frac{\mu_0 I \hat{z}}{4\pi d} (2 + (-1)) = \frac{\mu_0 I \hat{z}}{4\pi d}$$

$$\vec{B}_{BCP} = \frac{\mu_0 I \hat{z}}{4\pi d} = \frac{(4\pi \times 10^{-7} \frac{\text{Tm}}{\text{A}})(0.3\text{A}) \hat{z}}{4\pi(0.02\text{m})} = 1.5 \times 10^{-6} \text{T} \hat{z}$$

A substantial correction.

Solution to Part (d)

The distance from the segment CD to the point P is 2cm . The field points out of the page at point P by the right-hand rule for a wire. The field of an infinite straight wire,

$$\vec{B}_{CDP} = \frac{\mu_0 I}{2\pi r} \hat{z} = \frac{(4\pi \times 10^{-7} \frac{\text{Tm}}{\text{A}})(0.3\text{A})}{2\pi(0.02\text{m})} \hat{z} = 3 \times 10^{-6} \text{T} \hat{z}$$

Solution to Part (e)

Divide the wire into small segments. An element of the segment i is $\Delta \vec{\ell} = \Delta x \hat{x}$. The location of the i th segment is (x_i, d) and the displacement vector from the i th segment to the point P is

$$\vec{r}_{iP} = (0, 0) - (x_i, d) = (-x_i, -d)$$

The length of the displacement vector is

$$r_{iP} = \sqrt{(x_i^2 + d^2)}$$

Compute the cross-product

$$\Delta \vec{\ell} \times \vec{r}_{iP} = \Delta x \hat{x} \times (-x_i, -d) = -d \Delta x \hat{z}$$

which points out of the page since d is negative. The total field at P is the sum of the segments

$$\vec{B}_{CDP} = \sum_i \vec{B}_{iP}$$

Applying the Biot-Savart law to each segment

$$\vec{B}_{CDP} = \frac{\mu_0 I}{4\pi} \sum_i \frac{\Delta \vec{\ell} \times \vec{r}_{iP}}{r_{iP}^3} = \frac{\mu_0 I}{4\pi} \sum_i \frac{-d \Delta x \hat{z}}{(\sqrt{x_i^2 + d^2})^3} = -\frac{\mu_0 I d \hat{z}}{4\pi} \sum_i \frac{\Delta x}{(\sqrt{x_i^2 + d^2})^3}$$

Convert to an integral

$$\vec{B}_{CDP} = -\frac{\mu_0 I d \hat{z}}{4\pi} \int_0^\infty \frac{dx}{(\sqrt{x^2 + d^2})^3}$$

Integrals.com

$$\int \frac{dx}{(\sqrt{x^2 + d^2})^3} = \frac{x}{d^2 \sqrt{x^2 + d^2}}$$

$$\vec{B}_{CDP} = -\frac{\mu_0 I d \hat{z}}{4\pi} \left(\frac{x}{d^2 \sqrt{x^2 + d^2}} \right)_0^\infty = -\frac{\mu_0 I d \hat{z}}{4\pi d^2} = -\frac{\mu_0 I \hat{z}}{4\pi d}$$

Exactly half the infinite wire result, which was what we were expecting.

$$\vec{B}_{CDP} = 1.5 \times 10^{-6} \text{T} \hat{z}$$

26.2.2 Magnetic Field of Special Current Distributions

Magnetic Field of Current Loop: The magnetic field at a point P along the axis of a loop of wire of radius R carrying current I is

$$\vec{B} = B_x \hat{x} = \frac{\mu_0}{4\pi} \frac{2\pi R^2 I}{(x^2 + R^2)^{3/2}} \hat{x}$$

where x is the distance of point P from the center of the loop.

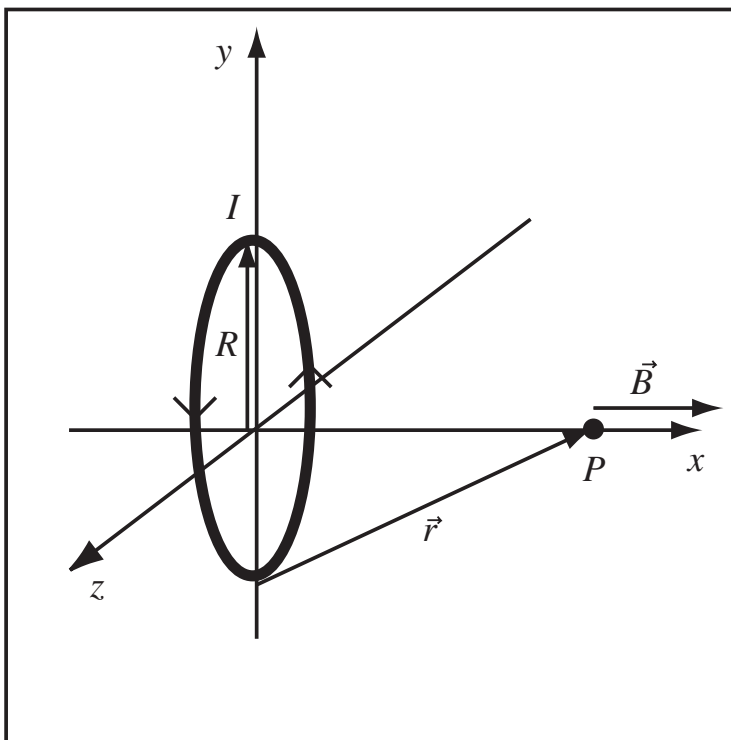

Example 26.8 Magnetic Field of Ring along Axis

Problem: A ring of radius 5cm carrying a 10A current lies in the $x - y$ plane and is centered at the origin. The current flows counterclockwise when viewed from the $+z$ side of the plane. Compute the magnetic field at $(0, 0, 2\text{cm})$.

Solution

The magnetic field of a loop of current of radius $R = 5\text{cm}$, a distance $z = 2\text{cm}$ along the axis of the loop is given by

$$B = \frac{\mu_0}{4\pi} \frac{2\pi R^2 I}{(z^2 + R^2)^{3/2}} = \frac{(4\pi \times 10^{-7} \frac{\text{Tm}}{\text{A}})}{4\pi} \frac{2\pi(5\text{cm})^2(10\text{A})}{((2\text{cm})^2 + (5\text{cm})^2)^{3/2}}$$

$$B = 1 \times 10^{-4} \text{T}$$

By the right hand rule, the magnetic field at $(0, 0, 2\text{cm})$ is in the $+\hat{z}$ direction, therefore

$$\vec{B} = 1 \times 10^{-4} \text{T} \hat{z}$$

Field of a Finite Solenoid: The magnetic field at a point a distance a from one end and b from the other end along the central axis of a finite solenoid with n turns per unit length carrying current I and having radius R is

$$|\vec{B}| = \frac{1}{2}\mu_0 n I \left(\frac{b}{\sqrt{b^2 + R^2}} + \frac{a}{\sqrt{a^2 + R^2}} \right).$$

Avoid the trap – n is *not* the number of turns of wire wrapped around the solenoid! It's the number of turns divided by the length that they are wrapped along the solenoid cylinder.

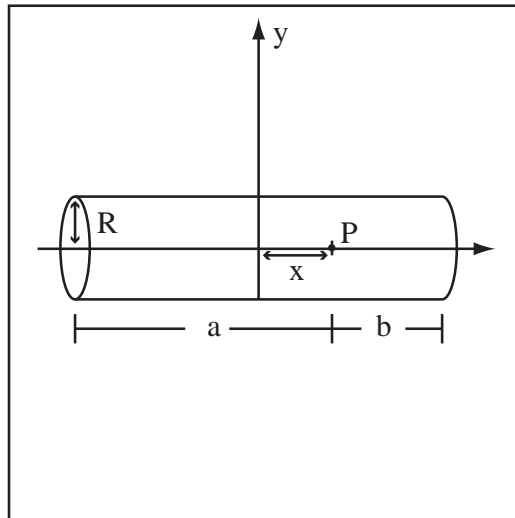

Chapter 27

Ampere's Law

27.1 Ampere's Law

27.1.1 Ampere's Law

Gauss' law was a reformulation of Coulomb's law that allowed the calculation of the electric charge if given the electric field. Ampere's law is a reformulation of the Biot-Savart law that allows the calculation of the current if the magnetic field is known.

Ampere's Law: The current, I_C through the surface bounded by a closed curve, C , is related to the line integral of the magnetic field B along the curve by

$$\oint \vec{B} \cdot d\vec{l} = \mu_0 I_C,$$

where I_C is positive if the thumb of the right hand is pointed in the direction of the current and the fingers curl in the direction of $d\vec{l}$.

27.1.2 How to Tackle Ampere's Law

Ampere's law has a flavor similar to Gauss's law, but the details are different. Just as we use Gauss's law to find \vec{E} fields for very symmetric charge distributions, we use Ampere's law to find \vec{B} fields for symmetric current distributions. With Gauss's law, we imagined Gaussian surfaces that were the boundaries of volumes, and we talked about how much charge was enclosed within that volume. Knowing how much charge was enclosed within the volume told us what the \vec{E} field was on the Gaussian surface.

With Ampere's law we focus on *curves* that are the boundaries of open *surfaces*. The line integral of \vec{B} around the curve, $\oint \vec{B} \cdot d\vec{l}$, is related to how much electric current cuts through the surface, which has the curve as its boundary. The curve used in Ampere's law is called an *Amperian path*. The surface bounded by the Amperian path can be any open surface at all—it doesn't necessarily have to be flat, and the Amperian path need not lie in a plane, either. Just as we have avoided “doing” integrals in Gauss's law, we'll also write down the answer to these Ampere's law integrals without doing any integrating. The strategy in Ampere's law problems is to imagine an appropriate Amperian path, use a sketch of the setup in order to find how much current cuts through the area inside the path, and then use the symmetry to write down the value of the integral and solve for \vec{B} .

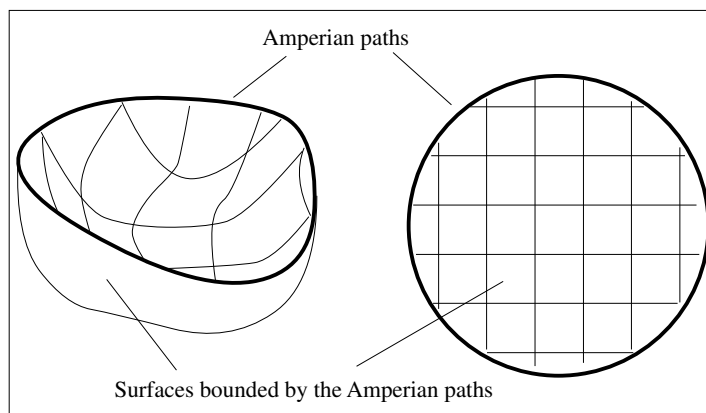

There are some algebraic sign conventions we need to learn regarding Ampere's Law. Recall when we used Gauss's Law, we defined electric flux to be positive or negative depending upon whether the \vec{E} field was directed out of or into the volume enclosed by the Gaussian surface. With Ampere's Law we need to give the current I a plus or minus sign depending on which way it goes through the cross section of the Amperian path. This choice is tied to the sense (think 'clockwise' vs. 'counterclockwise') in which we traverse the Amperian path in doing the line integral of \vec{B} around the path. The traditional "right-handed" choice is shown in this figure – the positive direction through the path's cross section is the direction your right thumb points when your right fingers curl around the path in the direction you traverse the path.

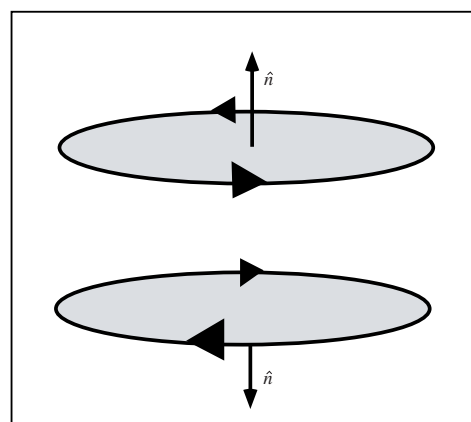

Just to confirm your understanding, here's another picture showing directions taken around the Amperian path and the corresponding algebraic signs of the current flowing through the cross section of the path.

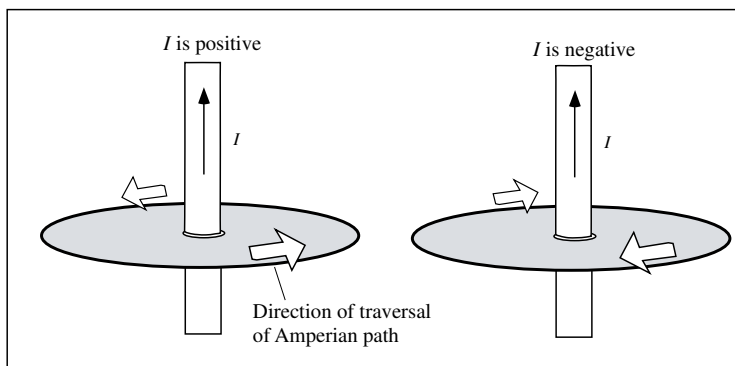

Maxwell's Equations Part II: Maxwell's Equations and the Lorentz force as introduced to this point are:

Maxwell's Equations

Gauss' Law $\int_S(\vec{E} \cdot \hat{n})dA = \frac{Q_{\text{enclosed}}}{\epsilon_0}$

No Magnetic Monopoles $\int_S(\vec{B} \cdot \hat{n})dA = 0$

Faraday's Law (Independence of Path) $\oint_C \vec{E} \cdot d\vec{\ell} = 0$ when there are no changing magnetic fields.

Ampere's Law $\oint_C \vec{B} \cdot d\vec{\ell} = \mu_0 I_C$ when there are no changing electric fields.

Lorentz Force

$$\vec{F} = q\vec{E} \quad \text{No Magnetic Fields}$$

27.1.3 Using Ampere's Law to Find Current in a Field Map

Qualitatively, Ampere's Law means that if you can find a closed path where the magnetic field generally points along the path, then there is a net current flowing through the surface bounded by the path. This means we can use Ampere's law to find currents in a magnetic field map. In the figure to the right, the magnetic field points mostly in the same direction as the path, so there is a current passing through the surface bounded by the path. The direction of the current can be found by the right-hand rule for a wire, which now we can recognize as the sign convention for Ampere's law.

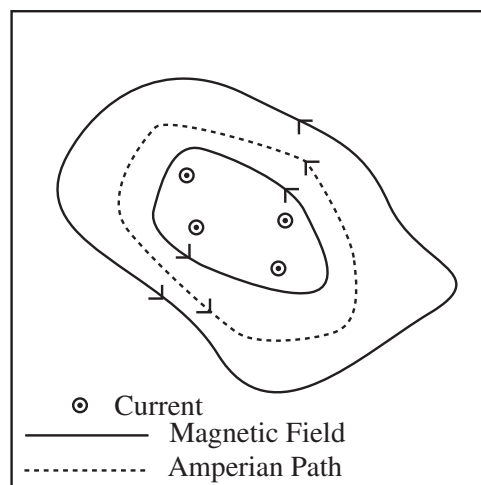

Example 27.1 Ampere's Law Applied to Non-Symmetric Field

Problem: The figure to the right shows an Amperian path (dashed) and a vector diagram of a magnetic field. Select the one of the following that is most true.

Select One of the Following:

- (a) There is no current flowing in the region. (b) There is a current flowing in the region around the Amperian path. (c) There is current flowing through the gray surface which is bounded by the Amperian path. (d) Cannot tell because Ampere's law only applies to cylindrical systems.

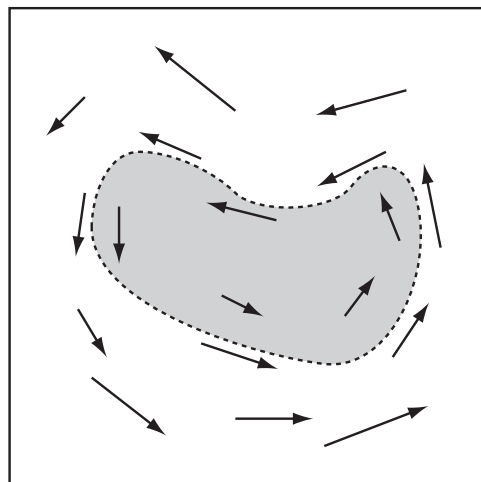

Solution

There is current flowing through the gray surface which is bounded by the Amperian path. Since the field points generally in the direction $d\vec{\ell}$, the integral

$$\oint_C \vec{B} \cdot d\vec{\ell} = \mu_0 I \neq 0$$

so a current flows through the surface bounded by the curve.

27.2 Cylindrical Systems

27.2.1 Ampere's Law in Cylindrical Systems

Ampere's law is a law of the universe. It applies in all cases where there are no changing magnetic fields. It is only useful for calculation in a few systems: solenoids and systems with cylindrical symmetry. This is the same situation we had with Gauss' law. All of the calculations you will be asked to do with Ampere's law are for systems with cylindrical symmetry; generally, it is for systems that look something like a co-axial cable. Since we will use the "right-hand rule for a wire" to find the direction of the field, your drawing is an important part of fully reporting the field.

Example 27.2 Drawing Magnetic Fields for Cylindrical Geometry

Problem: Two concentric cylinders carry current in opposite directions. The inner cylinder has 1.0mA flowing out of the page, the outer cylinder has 4.0mA flowing in the opposite direction. Draw the field map exterior to the conductors.

Solution

(a) **Draw the Conductors:** Draw the conductors, label the regions.

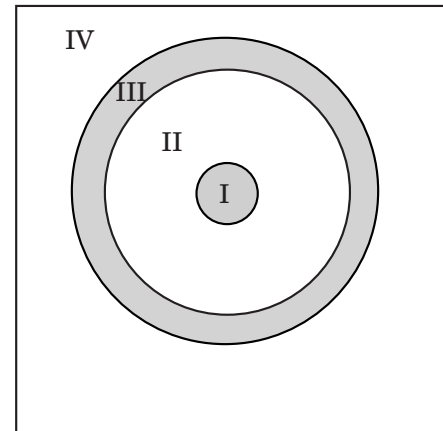

(b) Draw Currents: Draw the currents using \otimes for current into the page and \odot for current out of the page. Select a number of \odot and \otimes proportional to the current. Select the current in the inner cylinder 1.0mA to be 2 \odot , giving 8 \otimes flowing in the outer cylinder.

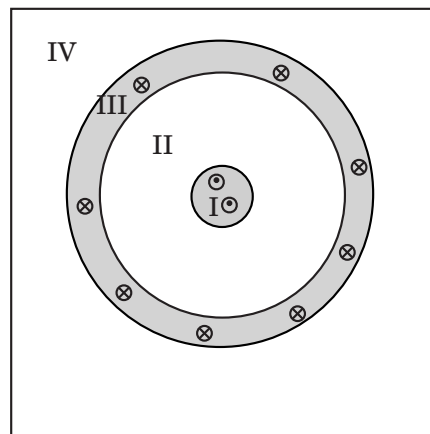

(c) Draw Fields: Use Right-Hand Rule for a wire on the total current passing through the surface bounded by the Amperian path in each region to determine the direction of the field. The field lines will be closed circles. In region *I* and *II* the total current enclosed is out of the page, so the field is counterclockwise. Somewhere in region *III*, the total current enclosed is zero and the field changes orientation. In region *IV*, the total current enclosed is into the page, so the direction of the field is clockwise. We do not draw the field in region *I* and *III* because we have not been asked to calculate the field in these regions.

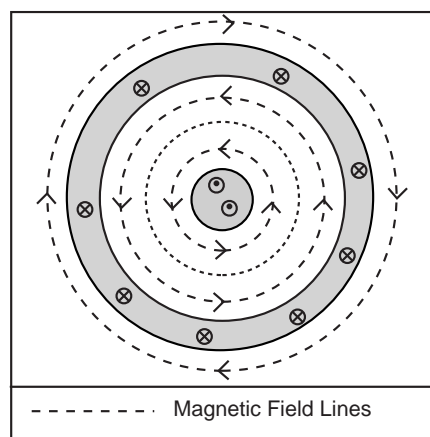

Example 27.3 Ampere's Law for Cylindrical Conductors

Problem: Two concentric cylinders carry current in opposite directions. The inner cylinder has 1.0mA flowing out of the page, the outer cylinder has 4.0mA flowing in the opposite direction. Calculate the magnetic field between the cylinders and outside both cylinders.

Solution

Definitions

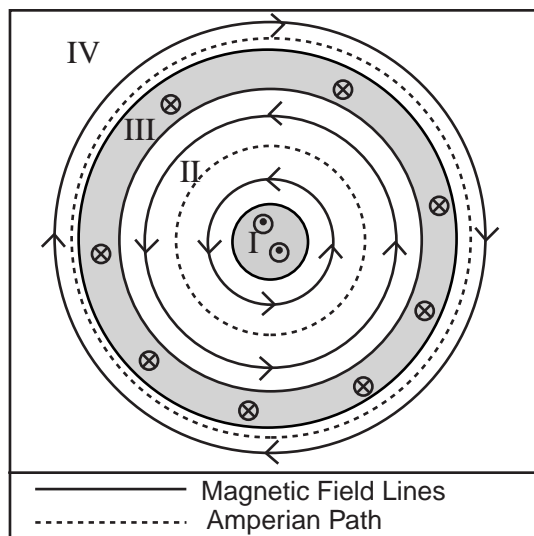

- $B_i \equiv$ Magnitude of Magnetic Field in Region *i*
- $d\vec{l} \equiv$ Element of length pointing along path
- $I_C \equiv$ Current enclosed by path
- $\vec{r} \equiv$ Radius of Path
- $I_i = 1.0\text{mA} \equiv$ Current through the inner conductor
- $I_o = 4.0\text{mA} \equiv$ Current through the outer conductor
- $I_{II} \equiv$ Total Current enclosed in Region II
- $I_{IV} \equiv$ Total Current enclosed in Region IV

Strategy: Argue that the field is constant along a circular path. Use Ampere's Law and divide by the length of the path to get the field, then use Right-Hand Rule for a Wire to get direction of B .

(a) Draw Good Figure: The diagram was drawn in Example 27.2 Drawing Magnetic Fields for Cylindrical Geometry. The problem only asks for the field in Regions II and IV . Draw a sample Amperian path on the diagram.

(b) Apply Ampere's Law: Apply Ampere's Law to a circular path. The current, I_C , through the surface bounded by a closed curve, C , is related to the integral of the magnetic field B along the curve by

$$\oint \vec{B} \cdot d\vec{l} = \mu_0 I_C.$$

Since \vec{B} is constant and parallel to every $d\vec{l}$ in the path, we can write Ampere's Law for this situation as

$$B \oint dl = \mu_0 I_C$$

The integral in this case is *always* the circumference of the Amperian loop, $2\pi r$, so the magnitude is given by

$$B = \frac{\mu_0 I_C}{2\pi r}$$

and the direction is found by using the right-hand rule on the net current enclosed.

(c) Apply Ampere's Law the Region II: Apply Ampere's Law to a circular Amperian path in region II . Use the right-hand rule for Ampere's law to select out-of the page as the positive direction for current. The current passing through the surface bounded by an Amperian path in region II is

$$I_C = I_i = 1.0\text{mA}$$

where I_i is the current flowing in the central conductor. Using the form of Ampere's Law specialized to the symmetry in Region II ,

$$\vec{B}_{II} = \frac{\mu_0 I_i}{2\pi r} \quad \text{counterclockwise}$$

where the direction can be deduced from the field map or from the direction of the Amperian path and the positive current direction.

(d) Apply Ampere's Law in Region IV: Apply Ampere's Law to a circular Amperian path in region IV . The total current flowing through the surface bounded by the Amperian path is

$$I_{IV} = I_i - I_o = -3.0\text{mA}.$$

where out-of the page represents positive current. Outside of the cylinders, in Region IV , the negative sign of the enclosed current indicates that the direction of the magnetic field is opposite to that in Region II . Applying Ampere's Law gives

$$\vec{B}_{IV} = \frac{\mu_0 (I_i - I_o)}{2\pi r} \quad \text{counterclockwise}$$

or since $I_o > I_i$

$$\vec{B}_{IV} = \frac{\mu_0 (I_o - I_i)}{2\pi r} \quad \text{clockwise}$$

Example 27.4 Cylindrical Tube Ampere's Law Problem

Problem: A infinite straight hollow conducting tube has inner radius 6cm and outer radius 8cm. It carries a current 5A out of the paper distributed uniformly in the tube. Compute the magnetic field everywhere. This will include drawing the magnetic field to indicate the direction of the field.

Solution

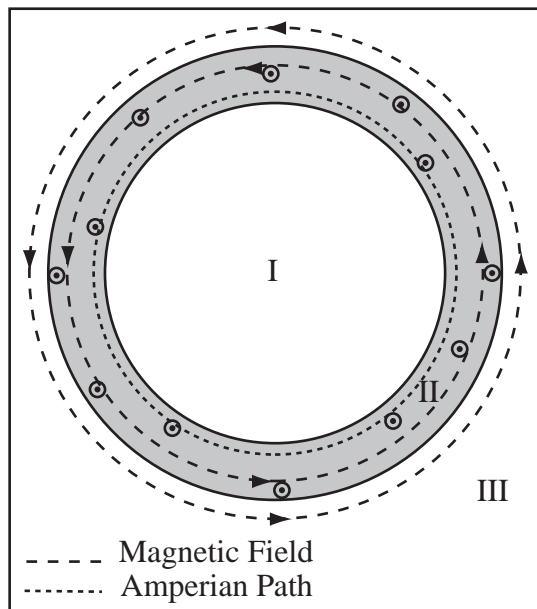

Definitions

$B_i \equiv$ Magnitude of Magnetic Field in Region i

$d\vec{l} \equiv$ Element of length pointing along path

$I_C \equiv$ Current enclosed by path

$\vec{r} \equiv$ Radius of Path

$I \equiv$ Current in Tube

$A_{tube} \equiv$ Total Cross-Sectional Area of Tube

$A_{enclosed} \equiv$ Cross-Sectional Area enclosed by Amperian Path

$r_{inner} \equiv$ Inner Radius of Tube

$r_{outer} \equiv$ Outer Radius of Tube

Strategy: Argue field constant along circular path. Use Ampere's Law and divide by the length of the path to get field, then use Right Hand Rule for a Wire to get direction of B . Compute the current enclosed in the tube as the ratio of the enclosed area to the total area.

(a) Specialize Ampere's Law for Cylindrical Symmetry: A sample Amperian path is drawn on the figure, by symmetry the field must point along the path. The current, I_C , through a surface bounded by the closed curve, C , is related to the integral of the magnetic field B along the curve by

$$\oint \vec{B} \cdot d\vec{l} = \mu_0 I_C.$$

Since the magnitude of \vec{B} is constant and the field is parallel to \vec{l} , we can write Ampere's Law for this situation as

$$B \oint dl = \mu_0 I_C$$

The integral in this case is *always* the circumference of the Amperian loop, $2\pi r$, so the magnitude is given by

$$B = \frac{\mu_0 I_C}{2\pi r}$$

and the direction by the right-hand rule using the net current enclosed.

(b) Apply Ampere's Law to Region I: In region I, the total current encircled by any Amperian path is zero, so the magnetic field is zero.

$$\vec{B}_I = 0$$

(c) Apply Ampere's Law the Region II: The total current encircled by an Amperian path of radius r through region II changes as the radius of the path changes. The total current flowing through the conductor is I . The fraction of this current encircled by the Amperian path is

$$I_C = I \frac{A_{enclosed}}{A_{tube}}$$

where $A_{enclosed}$ is the cross-sectional area enclosed by the Amperian path and A_{tube} is total cross-sectional area of the conducting tube. The two areas are $A_{tube} = \pi r_{outer}^2 - \pi r_{inner}^2$ and $A_{enclosed} = \pi r^2 - \pi r_{inner}^2$, therefore

$$I_C = I \frac{\pi r^2 - \pi r_{inner}^2}{\pi r_{outer}^2 - \pi r_{inner}^2}$$

Substituting this value into the expression for Ampere's Law appropriate for this symmetry allows the calculation of the magnetic field:

$$\vec{B}_{II} = \frac{\mu_0 I}{2\pi r} \frac{r^2 - r_{inner}^2}{r_{outer}^2 - r_{inner}^2} \quad \text{counterclockwise}$$

The direction of the field is found by pointing the thumb of your right hand in the direction of the current, then your fingers curl in the direction of the field, that is by applying the Right Hand Rule for a wire to the tube.

(d) Apply General Ampere's Law the Region III: The total current encircled by an Amperian path in Region III is $I_C = I = 5A$. Substituting this value into Ampere's Law yields

$$\vec{B}_{III} = \frac{\mu_0 I}{2\pi r} \quad \text{counterclockwise}$$

The direction of the field the same as B_{II} because the direction of the total enclosed current in the same.

27.3 Planar Systems

We can also guess the shape of the field for systems with planar symmetry.

Example 27.5 Magnetic Field of Current Sheet

Problem: This problem takes you through the process of calculating the magnetic field of a uniform sheet of current drawn below. Imagine a current flowing in a piece of sheet metal. A current per unit length $\lambda = I/L$ flows out of the sheet as drawn. L is the width of the sheet through which the current is flowing.

- Using figure (b) and the fact that symmetry implies the field is uniform and parallel to the current sheet, draw the magnetic field of the sheet. I have modelled the sheet as a collection of parallel wires to help you figure the direction of the field.
- The appropriate Amperian path is drawn in figure (a). Write the general form of Ampere's law and break up the integral along the four parts of the path. The integral along the path from b to c and from d to a can be discarded. Why?
- Let the distance from a to b (and from c to d) be ℓ . By symmetry the field must have an equal magnitude on the two parts. Do the integral and report the formula for the magnetic field of a sheet of current.
- Use your formula. If 20A flows down a sheet that is 2m wide, calculate the magnetic field near the sheet.

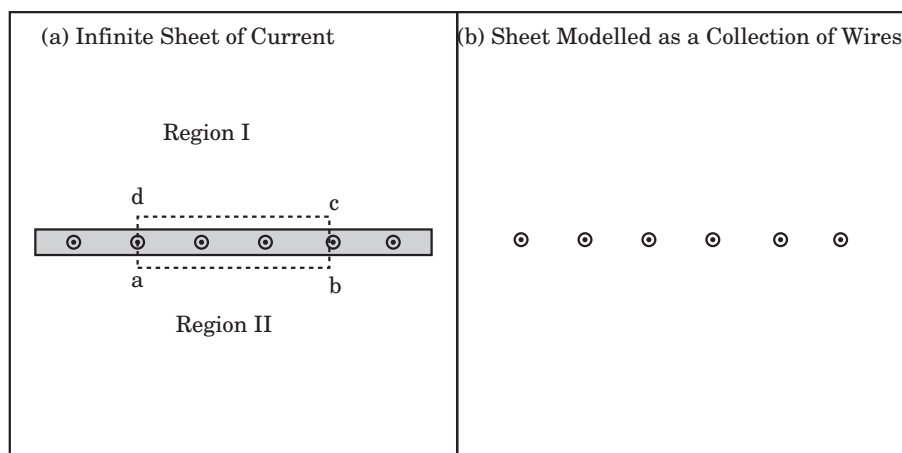

Solution to Part (a)

Using the right hand rule for a wire and the information given in the problem the field is as drawn.

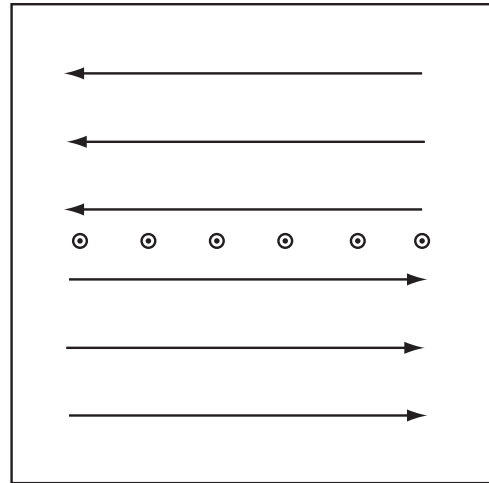

Solution to Part (b)

Ampere's law states

$$\int_C \vec{B} \cdot d\vec{\ell} = \mu_0 I_{enc}$$

$$\int_C \vec{B} \cdot d\vec{\ell} = \int_a^b \vec{B} \cdot d\vec{\ell} + \int_b^c \vec{B} \cdot d\vec{\ell} + \int_c^d \vec{B} \cdot d\vec{\ell} + \int_d^a \vec{B} \cdot d\vec{\ell} = \mu_0 I_{enc}$$

The b,c and d,a segments are zero because \vec{B} is perpendicular to $d\vec{\ell}$ so, $\vec{B} \cdot d\vec{\ell} = 0$.

Solution to Part (c)

$$\int_C \vec{B} \cdot d\vec{\ell} = \int_a^b \vec{B} \cdot d\vec{\ell} + \int_c^d \vec{B} \cdot d\vec{\ell} = \mu_0 I_{enc}$$

The magnetic field is constant along both paths and parallel to the path

$$\int_a^b \vec{B} \cdot d\vec{\ell} = \int_a^b B d\ell = B \int_a^b d\ell = B\ell$$

So

$$2B\ell = \mu_0 I_{enc}$$

The current passing through the path is $\lambda\ell$

$$2B\ell = \mu_0 I_{enc} = \mu_0 \lambda \ell$$

$$B = \frac{\mu_0 \lambda}{2}$$

Solution to Part (d)

The current density $\lambda = 20\text{A}/2\text{m} = 10\text{A}/\text{m}$

$$B = \frac{\mu_0 \lambda}{2} = \frac{(4\pi \times 10^{-7} \frac{\text{Tm}}{\text{A}})(10\text{A}/\text{m})}{2} = 2\pi \times 10^{-6} \text{T}$$

27.4 Solenoids

Ampere's law can also be used to calculate the field of an infinite solenoid. The reasoning is very different from the cylindrical case. Unless one counts the toroidal solenoid, which is a solenoid wrapped in a circle, there are not any other systems where the reasoning applies. You are required to understand the argument, but I will not ask you to reproduce it.

Example 27.6 Ampere's Law for Solenoid

Problem: An infinite solenoid carries a current I and is wound with n turns per unit length. Calculate the magnetic field of the solenoid.

Solution

Strategy: Choose Amperian Path along axis of solenoid, argue that only the inside leg contributes, then use Ampere's Law.

(a) Draw the System and Select the Path: The figure with the directions of the currents labelled is shown to the right. The Amperian path is drawn.

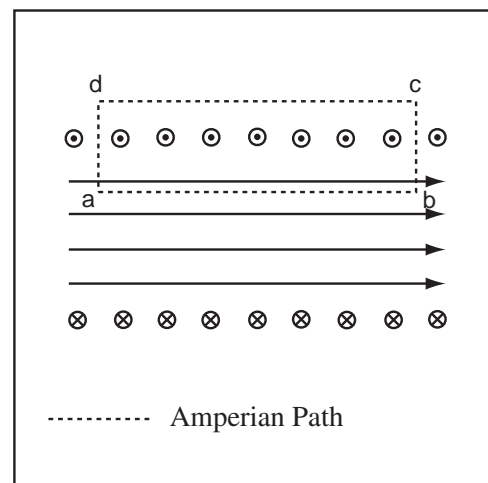

(b) Use Symmetry: The solenoid is cylindrically symmetric about its axis, so the field must have that symmetry. There are a few possibilities: (1) Radially outward like the electric field of an infinite line charge, (2) Circles around the axis of the solenoid like the magnetic field of a long wire running down the axis of the solenoid, or (3) Straight lines parallel to the axis with field strength that depends only on the distance from the axis, $\vec{B} = B(r)\hat{x}$ where \hat{x} is the direction of the axis. The first possibility implies a line of magnetic charge down the axis and therefore is physically impossible. The second possibility violates Ampere's law. If an Amperian path were to follow one of the field circles there would be a net field around the path, but no current flowing through the path. Therefore the field lines must be straight lines parallel to the axis of the solenoid of the form $\vec{B} = B(r)\hat{x}$.

(c) Reason Field Along Path: The field is perpendicular to the Amperian Path from b to c and from d to a , so $\vec{B} \cdot d\vec{l} = 0$. What about the leg c to d ? Choose an Amperian path where the leg c to d is at infinity. Infinitely far from the solenoid all the current in the solenoid appears to be flowing at the axis. Since each element of current flowing in one direction has an equal and opposite current flowing in the opposite direction, their magnetic fields cancel if we are far enough from the solenoid and the field at infinity is zero. Therefore the contribution of leg c to d is zero.

(d) Compute Current Encircled: If the length of a to b is L , then the current enclosed by the path is $I_C = nLI$. Since n is the number of turns per unit length, nL is the number of times the wire passes through the surface. If this is multiplied by the current, the total current through the Amperian path is found $I_C = nLI$.

(e) Use Ampere's Law: The current, I_C , through a closed curve, C , is related to the integral of the magnetic field B along the curve by

$$\oint \vec{B} \cdot d\vec{l} = \mu_0 I_C$$

therefore

$$B_{ab}L = \mu_0 I_C = \mu_0 nLI$$

$$B_{ab} = n\mu_0 I$$

Exactly what we expected.

(f) Apply Right-Hand Rule for Wire: Use the Right-Hand Rule for a Wire to get the direction of the field. Grab one of the wires with your right hand so your thumb points in the direction of current flow. The tips of your fingers inside the solenoid point in the direction of the field inside. This is because the field inside must add up from the individual elements of current.

We actually found this result directly from the Biot-Savart law last chapter by first finding the field of a ring, then integrating to get the field of the finite solenoid, then letting the solenoid length go to infinity. This was profoundly easier.

Example 27.7 Field of a Toroidal Solenoid

Problem: This problem takes you through the steps needed to calculate the magnetic field of a toroidal solenoid from Ampere's Law. A toroidal solenoid is a solenoid wrapped on a circular tube. The appropriate Amperian path is drawn as a dashed line in the figure to the right. The radius of the path is r . Assume the circles with radii a , b , and r are all in the same plane. The solenoid is wound with N turns.

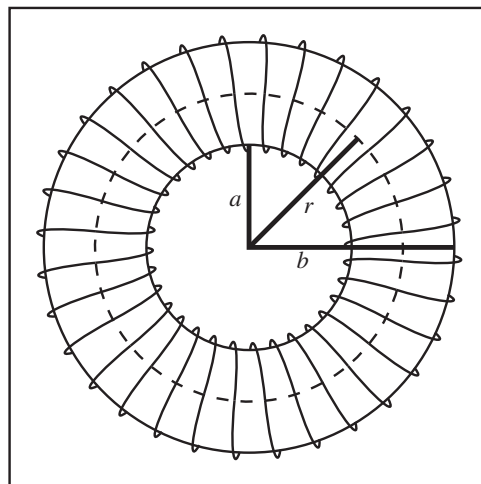

- If current I flows through the wire, what is I_{enc} ?
- Evaluate $\oint \vec{B} \cdot d\vec{\ell}$. The reasoning is the same as for cylindrical symmetry.
- Calculate the magnetic field of a toroidal solenoid.

Solution to Part (a)

We know the number of wires intersecting the surface bounded by the Amperian path, so we simply multiply this by I to get the encircled current:

$$I_{enc} = NI$$

Solution to Part (b)

By the symmetry of the situation, the field inside the solenoid will always be perpendicular to the radial vector, which makes it parallel to our Amperian path, and the field will have constant magnitude along the path. The direction of the field will of course depend on the direction of the current, but if we assume that the line integral is evaluated in the same direction as the field. Since the field and the path are always parallel, $\vec{B} \cdot d\vec{\ell} = B d\ell$, by the properties of the dot product of parallel vectors. Since the field is constant on the path, we can re-write the integral part of Ampere's law as

$$\oint \vec{B} \cdot d\vec{\ell} = \oint B d\ell = B \oint d\ell$$

The remaining integral is just the length of the path, the circumference of the circle, $2\pi r$

$$\oint \vec{B} \cdot d\vec{\ell} = B(2\pi r)$$

Solution to Part (c)

Ampere's Law is

$$\oint \vec{B} \cdot d\vec{\ell} = \mu_0 I_{enc}$$

and from this relationship we can now solve for the field.

$$B(2\pi r) = \mu_0 NI$$

$$B = \frac{\mu_0 NI}{2\pi r}$$

This equation tells us that, unlike an infinite straight solenoid, the field inside a toroidal solenoid is not constant, but is stronger closer to the inner surface. The field outside the solenoid is zero.

Chapter 28

Magnetic Force

28.1 Magnetic Force

28.1.1 The Lorentz Force

Magnetic fields exert forces on moving charges. The moving charges can either be in the form of a single moving electric charge or a current of charges in a wire. A magnetic field exerts no force on a stationary charged particle. The amount of force exerted on moving charge is given by the Lorentz Force, which we will write for a moving charge and for a current.

Magnetic Force on a Stationary Charge: The magnetic force on an unmoving charge is always zero.

Magnetic Force on a Moving Charge (Lorentz Force): The magnetic force, \vec{F} , on a particle with charge q and velocity \vec{v} moving through magnetic field \vec{B} is

$$\vec{F} = q\vec{v} \times \vec{B}.$$

Remember \times represents a vector cross product—this makes the magnetic force on the particle perpendicular to both the particle's velocity and to the magnetic field it is moving through. Magnetic forces act “sideways,” to put it crudely.

Force on a Small Segment of Current-Carrying Wire: A current-carrying wire feels a magnetic force if it is in a magnetic field. The force, dF on a small segment depends on the current I through the wire, the segment's length and orientation $d\vec{\ell}$, and the magnetic field \vec{B}

$$dF = Id\vec{\ell} \times \vec{B}.$$

If the magnetic field is constant over the length of a straight wire, the total force on the wire is

$$F = I\vec{\ell} \times \vec{B},$$

where $|\vec{\ell}|$ is the length of the wire. Note: The vector $\vec{\ell}$ points in the direction of the current flow.

To apply the Lorentz force, we have to work out the same kind of cross products we have been using throughout magnetic fields. Both $+$ and $-$ charges feel the magnetic force, so we have to be careful of the sign of q when evaluating the direction of the Lorentz force.

Example 28.1 Electron Shot into Magnetic Field

Problem: An electron is shot along the x -axis in the $+x$ direction with velocity $|\vec{v}| = 1 \times 10^6 \frac{\text{m}}{\text{s}}$. A uniform magnetic field, $B = 0.25\text{T}\hat{z}$ fills the region $x > 0$.

(a) Draw a diagram showing the force and field.

(b) Compute the force on the particle as it enters the magnetic field.

Solution to Part(a)

The force on the particle as it enters the field is given by the Lorentz Force,

$$\vec{F} = q\vec{v} \times \vec{B}$$

where q is the charge, \vec{v} is the velocity, and \vec{B} is the magnetic field. Using the right hand rule, pointing your fingers in the direction of the velocity, and curling in the direction of the field, we find that the vector $\vec{v} \times \vec{B}$ points in the $-\hat{y}$ direction. Therefore, since an electron has a negative charge, the magnetic force points in the $+\hat{y}$ direction.

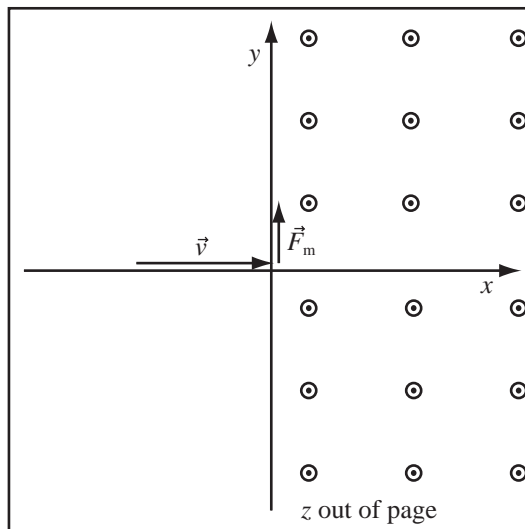

Solution to Part(b)

Since \vec{v} is perpendicular to \vec{B} as the electron enters the field,

$$|\vec{F}_m| = |q|vB = (1.6 \times 10^{-19}\text{C})(1 \times 10^6 \frac{\text{m}}{\text{s}})(0.25\text{T}) = 4 \times 10^{-14}\text{N}$$

$$\vec{F}_m = 4 \times 10^{-14}\text{N}\hat{y}$$

Example 28.2 Compute the Force on a Current-Carrying Wire in a Uniform Magnetic Field

Problem: A current of 3.0A moves through a wire that is 12cm long. The current flows in the $+\hat{x}$ direction. The wire is in a region of constant magnetic field of $4.0 \times 10^{-7}\text{T}$ in the $+\hat{z}$ direction. Compute the force, magnitude and direction, on the wire due to the magnetic field.

Solution

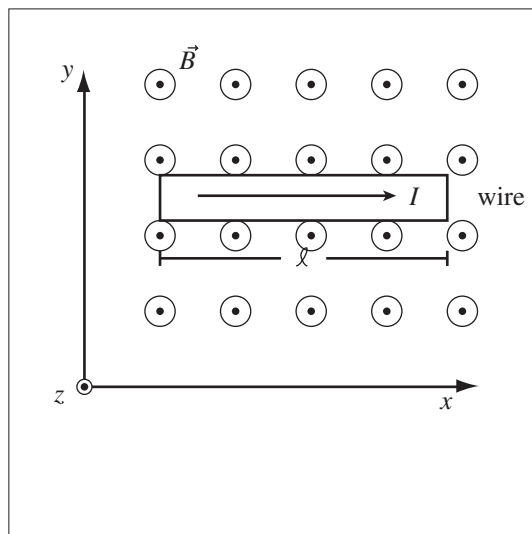

Definitions

$\vec{B} = 4.0 \times 10^{-7} \text{T} \hat{z} \equiv$ Constant, uniform magnetic field

$I = 3.0 \text{A} \equiv$ Current

$l = 12 \text{cm} \equiv$ Length of current-carrying wire

$\vec{F}_m \equiv$ Magnetic force on the wire

(a) **Use Lorentz Force:** The force on the wire is given by the Lorentz Force

$$\vec{F}_m = I \vec{l} \times \vec{B}.$$

(b) **Use Right-Hand Rule:** Use RHR to get the direction of the force, point the fingers in \vec{l} direction and curl them in the \vec{B} direction, giving the direction of \vec{F}_m as the $-\hat{y}$ direction.

(c) **Use Magnitude Form of Cross Product:**

$$F_m = I \ell B \sin \theta$$

The angle between the current and the magnetic field is 90° , and $\sin 90^\circ = 1$, so

$$F_m = I \ell B$$

$$F_m = 3.0 \text{A} \cdot 12 \times 10^{-2} \text{m} \cdot 4.0 \times 10^{-7} \text{T} = 1.4 \times 10^{-7} \text{N}$$

$$F_m = 1.4 \times 10^{-7} \text{N} \quad \text{in the } -y \text{ direction}$$

Example 28.3 Figuring Out the Direction of the Field You Need

Problem: A 10cm wire carrying a current of 6A in the $+\hat{y}$ direction lies parallel to the y -axis.

(a) What direction must a uniform magnetic field be in to generate a force on the wire in the $+z$ direction?

(b) What must the magnitude of this field be to exert a force of 0.10N on the wire segment?

Solution to Part(a)

The force on a current carrying wire is

$$\vec{F} = I \vec{l} \times \vec{B},$$

so for a force in the $+\hat{z}$ direction if $\vec{l} = |\ell| \hat{y}$, we need $\hat{z} = \hat{y} \times \hat{B}$. Executing the right hand rule gives $\hat{B} = -\hat{x}$.

Solution to Part(b)

The magnitude of the force for the geometry given above is $F = ILB$, so

$$B = \frac{F}{IL} = \frac{0.1\text{N}}{(6\text{A})(10\text{cm})} = 0.166\text{T}$$

With the Lorentz force, we complete the set of equations that govern the motion of charged particles in static electromagnetic fields.

Maxwell's Equations: Maxwell's Equations and the Lorentz force as introduced to this point are:

Maxwell's Equations

Gauss' Law $\int_S(\vec{E} \cdot \hat{n})dA = \frac{Q_{\text{enclosed}}}{\epsilon_0}$

No Magnetic Monopoles $\int_S(\vec{B} \cdot \hat{n})dA = 0$

Faraday's Law (Independence of Path) $\oint_C \vec{E} \cdot d\vec{\ell} = 0$ when there are no changing magnetic fields.

Ampere's Law $\oint_C \vec{B} \cdot d\vec{\ell} = \mu_0 I_C$ when there are no changing electric fields.

Lorentz Force

$$\vec{F} = q\vec{E} + q\vec{v} \times \vec{B}$$

28.1.2 Consequences of the Form of the Lorentz Force

The cross product relation between the velocity and the force makes the direction of motion and the force always perpendicular. This leads to the following two unusual properties of motion in a magnetic field:

Magnetic Field Does No Work: The magnetic force is always perpendicular to the velocity, $\vec{F} = q\vec{v} \times \vec{B}$, which implies that the magnetic force is always perpendicular to $\Delta\vec{x}$, the particle's displacement during a short time interval Δt . Therefore, the magnetic field does no work, since the dot product of perpendicular vectors is always zero—

$$W = \vec{F} \cdot \Delta\vec{x} = 0.$$

Speed Does Not Change when Travelling in a Magnetic Field: If the magnetic field does no work, then it does not change the energy of the particle. If the energy stays the same, the magnitude of the velocity cannot change since the kinetic energy is $\frac{1}{2}mv^2$. Therefore, a particle moving in a magnetic field changes direction, but moves at a constant speed.

We will use these properties later in the section to describe the motion of a charged particle in a uniform magnetic field. First, though let's consider the motion of charged particle where the magnetic force is balanced by some other force.

Example 28.4 Force on Proton in Particle Accelerator

Problem: A proton travels parallel to the ground in a particle accelerator. If it travels at 5% of the speed of light, what direction and how strong must a magnetic field be to balance gravity and keep it travelling parallel to the ground.

Solution

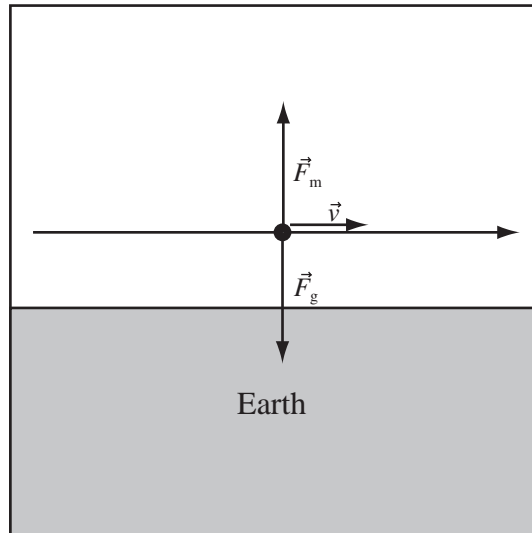

Definitions

$$q = 1.6 \times 10^{-19} \text{C} \equiv \text{Charge of Proton}$$

$$\vec{F}_m \equiv \text{Magnetic Force}$$

$$\vec{F}_g \equiv \text{Gravitational Force}$$

$$\vec{v} = 0.05c \equiv \text{Velocity of Proton}$$

$$m = 1.67 \times 10^{-27} \text{kg} \equiv \text{Mass of Proton}$$

$$\vec{B} \equiv \text{Magnetic Field to Balance Gravity}$$

Strategy: Use Newton's Second Law to balance the gravitational force against the Lorentz Force.

(a) Write Force Balance: The problem states the magnetic force balances the gravitational force, so

$$\vec{F}_g + \vec{F}_m = 0,$$

and therefore

$$|\vec{F}_g| = |\vec{F}_m|.$$

The direction of the gravitational force is downward and therefore the direction of the magnetic force is upward.

(b) Compute Gravitational Force: The magnitude of the force of gravity is $F_g = mg$.

(c) Compute Magnetic Force: The magnetic force on the proton is $\vec{F} = q\vec{v} \times \vec{B}$. We will select a magnetic field perpendicular to the velocity, so the magnitude of the magnetic field is $F_m = qvB$.

(d) Compute the Magnetic Field: Balance the magnetic and gravitational force,

$$F_m = qvB = mg = F_g.$$

Solving for B gives,

$$B = \frac{mg}{qv} = \frac{(1.67 \times 10^{-27} \text{kg})(9.81 \frac{\text{m}}{\text{s}^2})}{(1.6 \times 10^{-19} \text{C})(0.05)(3 \times 10^8 \frac{\text{m}}{\text{s}})}$$

$$|\vec{B}| = 6.83 \times 10^{-15} \text{T}$$

(e) The rest of the answer, Reason About Direction: Using the right hand rule, point your fingers in the direction of the velocity and your thumb in the direction you want the force to point—upward. With these directions, your fingers curl into the page. Therefore, since the charge is positive, the magnetic field points into the page.

28.1.3 Newton's Third Law and the Magnetic Force

I have repeatedly stated that Newton's Third Law is true because momentum does not leak out of the universe. Bizarrely, which seems to be the only way we do things in magnetism, Newton's III law is not true for magnetic forces on isolated charges as the following example demonstrates. This is a disaster because if we leave this unresolved the universe would rapidly grind to a halt. The answer lies a bit beyond the scope of the class. The momentum is temporarily stored in the electromagnetic fields themselves.

Example 28.5 Mutual Lorentz Forces

Problem: The figure below shows two systems of two charges, Q_1 and Q_2 . The arrows indicate the velocity.

- Draw the direction of \vec{B}_{12} and \vec{B}_{21} for each system. Indicate if the field is zero.
- Draw the direction of \vec{F}_{12} and \vec{F}_{21} , the Lorentz forces the elements exert on each other.
- For which system, if any, does Newton's Third Law apply?

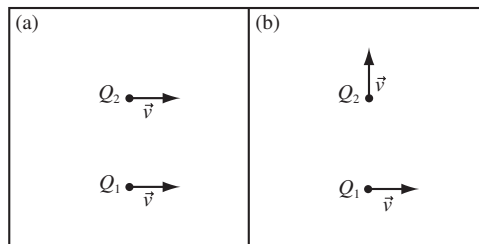

Solution to Part (a)

The direction of the fields can be found by using $\vec{v} \times \hat{r}$ from the Biot-Savart Law and the Right Hand Rule. The proper directions are shown in the figure. Since the displacement vector from Q_2 to Q_1 in figure (b) is parallel to the velocity of Q_2 , the field at Q_1 due to Q_2 is zero.

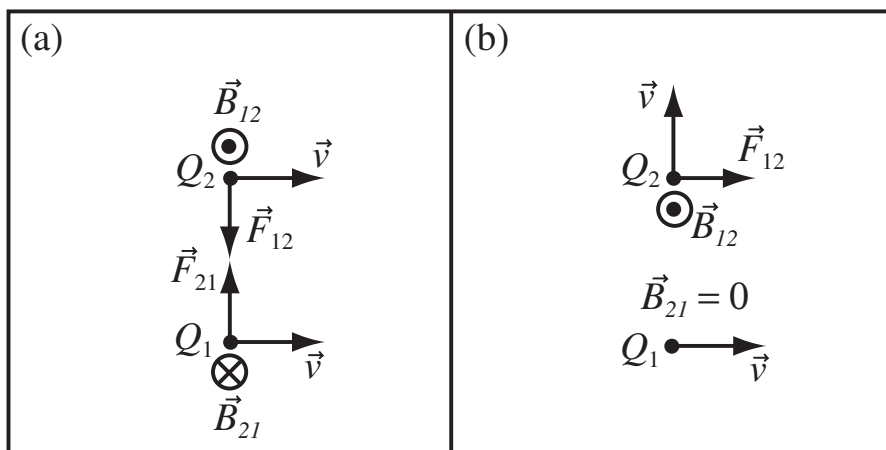

Solution to Part (b)

The Lorentz force is

$$\vec{F} = q\vec{v} \times \vec{B}$$

so the direction is found with the right hand rule. In figure (b), Q_2 produces zero magnetic field at Q_1 , so at the instant in time represented by the figure, the motion of Q_1 does not interact with the field of Q_2 , so there is no resulting Lorentz force. See the figure above.

Solution to Part (c)

Newton's Third Law does not apply to magnetic forces. It seems to apply in the figure (a), but this is a coincidence. It clearly does not apply in figure (b).

28.2 Circular Motion in a Uniform Magnetic Field

The Lorentz Force Law, when applied to a particle moving in a uniform (constant) magnetic field, produces some interesting behavior. The speed of the particle is constant, but the acceleration is always at right angles to the direction of motion, so the particle keeps turning. If the field is uniform, the magnitude of the force is constant, and the particle moves in a circle. The acceleration of any object moving in a circular orbit is given by the centripetal acceleration:

Centripetal Acceleration: The acceleration of a particle moving in a circle at constant speed is

$$a_c = \frac{v^2}{r}$$

directed inward toward the center of motion, where v is the speed of the particle and r is the radius of its circular orbit.

The acceleration is related to the magnetic force by Newton's Second Law

$$\vec{F}_m = m\vec{a}_c = m\frac{v^2}{r} \quad \text{inward}$$

If the particle enters the field perpendicular to it, then the orbit is a closed circle; otherwise, the orbit is a spiral. The Lorentz force is

$$\vec{F} = q\vec{v} \times \vec{B}$$

and since the velocity is perpendicular to the magnetic field, the magnitude of the Lorentz Force is

$$F_m = qvB.$$

Using this in Newton's Second Law gives

$$F_m = qvB = ma_c = m\frac{v^2}{r}$$

We can solve this expression for the charge, the velocity, or the radius of the orbit. This means we can take a picture of a charged particle moving in a magnetic field and if we know the charge, we can use the radius to tell us the velocity.

Circular Motion in a Magnetic Field: A particle with charge q , mass m , and velocity v will travel in a circular orbit in a uniform magnetic field with strength B . The radius of the orbit, r , satisfies:

$$qvB = m\frac{v^2}{r}$$

Example 28.6 Motion of Charged Particle in Constant Magnetic Field

Problem: A proton maintains a velocity of $0.50 \times 10^3 \frac{\text{m}}{\text{s}}$ when it enters a region of constant magnetic field of magnitude $4.0 \times 10^{-5} \text{T}$. The initial velocity of the proton ($+\hat{y}$) is perpendicular to the direction of the magnetic field, ($+\hat{z}$).

- What is the proton's trajectory (include the direction and radius)?
- What is the period of the orbit?

Definitions

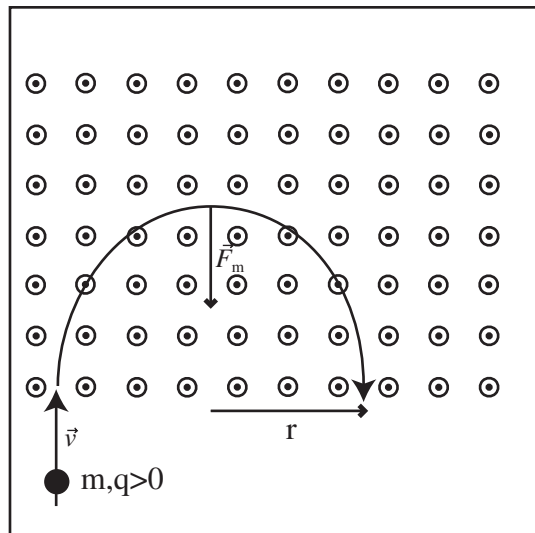

- $B = 4.0 \times 10^{-5} \text{T} \equiv$ Magnitude of Magnetic Field
- $q = 1.602 \times 10^{-19} \text{C} \equiv$ Charge of proton
- $m = 1.67 \times 10^{-27} \text{kg} \equiv$ Mass of proton
- $r \equiv$ Radius of Circle
- $v_0 = 0.50 \times 10^3 \frac{\text{m}}{\text{s}} \hat{y} \equiv$ Initial velocity of particle
- $F_m \equiv$ Magnetic Force
- $a_r \equiv$ Centripetal Acceleration
- $F_r \equiv$ Centripetal Force
- $T \equiv$ Period of Orbit

Strategy: Use Newton's Second Law to relate the magnetic force to the centripetal acceleration and solve for the radius.

Solution to Part (a)

(a) Use Right Hand Rule to Get Direction of Circle: Using the RHR on the $q\vec{v}_0 \times \vec{B}$ factor in the Lorentz force gives an initial force to the right and a trajectory as drawn in the diagram.

(b) Use Formula For Centripetal Acceleration: The acceleration of a particle moving in a circle at a constant speed is

$$a_c = \frac{v^2}{r}$$

and is directed toward the center of the circle.

(c) Compute Magnetic Force: The force on a particle moving in a field is given by the Lorentz force,

$$\vec{F}_m = q\vec{v} \times \vec{B}.$$

Since \vec{v} is perpendicular to \vec{B} and we've already picked the correct orientation of the circle, $F_m = qvB$ will be directed inward, toward the center of the trajectory circle.

(d) Apply Newton's Second Law: The force on the proton equals the mass times the acceleration, by Newton's Second Law. Since both the force and acceleration are directed toward the center of the trajectory circle, we can write

$$\begin{aligned} F_m &= ma_c = m \frac{v^2}{r} \\ qvB &= \frac{mv^2}{r} \\ r &= \frac{mv}{qB} \end{aligned}$$

(e) Substitute and Solve:

$$r = \frac{1.67 \times 10^{-27} \text{kg} \cdot 0.50 \times 10^3 \frac{\text{m}}{\text{s}}}{1.602 \times 10^{-19} \text{C} \cdot 4.0 \times 10^{-5} \text{T}} = 0.13 \text{m}$$

Solution to Part (b)

Compute the Period: Since magnetic fields do no work, the velocity is constant (Conservation of Energy). The period is the time it takes the proton to go around the circle, so it's the circumference of the circle divided by the magnitude of the proton's velocity,

$$T = \frac{2\pi r}{v_0} = \frac{2\pi(0.13\text{m})}{0.5 \times 10^3 \text{m/s}} = 1.6 \times 10^{-3} \text{s}.$$

For calculating the period, it doesn't matter which way the particle is going around the circle. Periods aren't negative, so we always just use the magnitude of the velocity.

28.3 Forces on Currents and Wires

Now place a moving charge in the magnetic field and reason about the direction of the force. As with electric fields, we do not include the field of the object that is feeling the force in the field maps we use to compute the force. We start with the simplest cases first, a charged particle shot into a magnetic field and an infinite wire in the field of other infinite straight wires. In both cases, the object feels a uniform force or force per unit length which we can work out through the Lorentz force.

Example 28.7 Force on a Particle Travelling in a Field

Problem: For the wires to the left, which carry the same magnitude of current:

- Draw the magnetic field with three lines per wire.
- Draw the direction of the magnetic force on an electron shot into the page at point P .

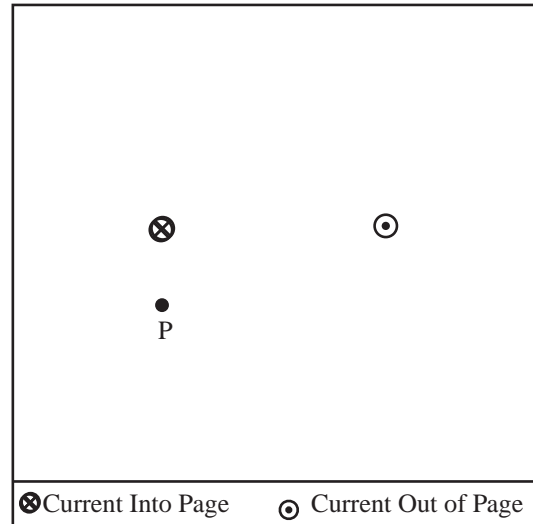

Solution to Part (a)

Draw the magnetic field using techniques from Section 29.1 Drawing and Reading Magnetic Field Maps.

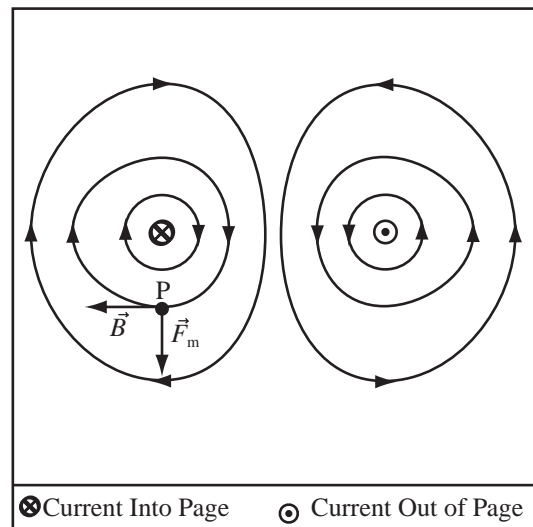

Solution to Part (b)

From the drawing, the magnetic field points to the left at P . The Lorentz force is $\vec{F}_m = q\vec{v} \times \vec{B}$. Using the right hand rule, $\vec{v} \times \vec{B}$ points upward at point P , so \vec{F}_m points downward since $q < 0$ for an electron.

Example 28.8 Force on Proton in a Magnetic Field

Problem: For the configuration of wires at the right, all are carrying the same magnitude of current:

- (a) Draw the magnetic field map.
 (b) A proton is shot into the page at point P . Sketch the direction of the force on the proton.

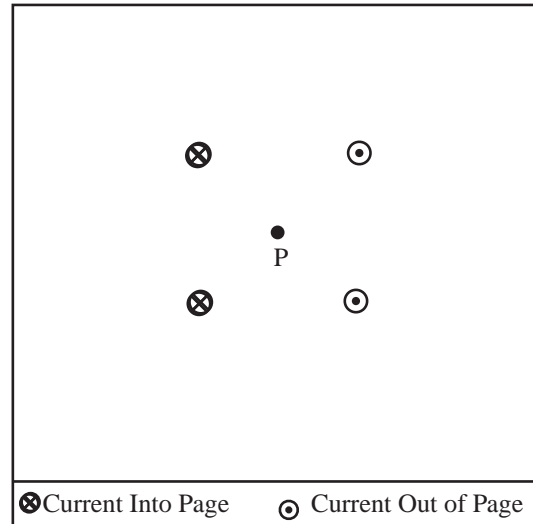

Solution to Part(a)

The magnetic field map is shown to the right. The directions of the field lines were found using the right hand rule.

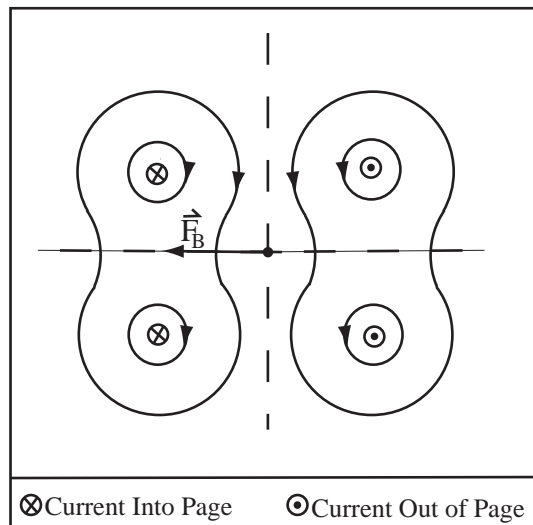

Solution to Part(b)

Use $\vec{F} = q\vec{v} \times \vec{B}$ and the right hand rule to get the force drawn in the figure above.

Chapter 29

Magnetic Dipoles

29.1 Drawing and Reading Magnetic Field Maps

29.1.1 Drawing the Magnetic Field of a Magnetic Dipole

All magnetic fields of localized charge distributions (the infinite wire is not localized) are dipole fields. Just as an electric dipole field was characterized by an electric dipole moment vector, \vec{p} , a magnetic dipole field is characterized by a magnetic dipole moment vector, \vec{m} .

Shape of Magnetic Dipole Field and Dipole Moment Vector: The shape of a magnetic dipole field resulting from an object with magnetic dipole moment vector \vec{m} is shown below. The vector \vec{m} will also be called the magnetic moment.

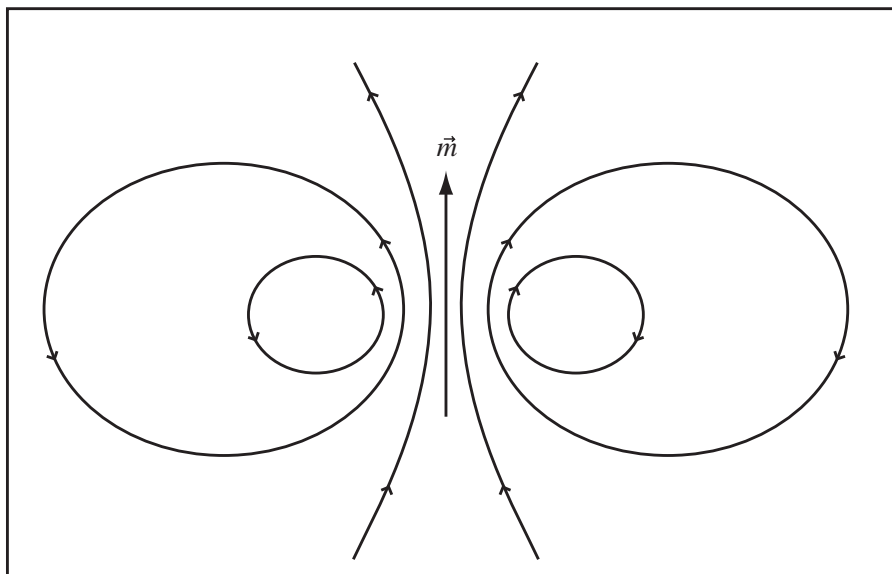

An Isolated Loop of Current Produces a Dipole Field: The field of a ring of wire which carries current I in the direction drawn is shown below. To find the direction of the magnetic moment use the right hand rule for the wire to figure out the direction of the field interior to the loop, the magnetic dipole moment points in the same direction as the field in the center of the loop.

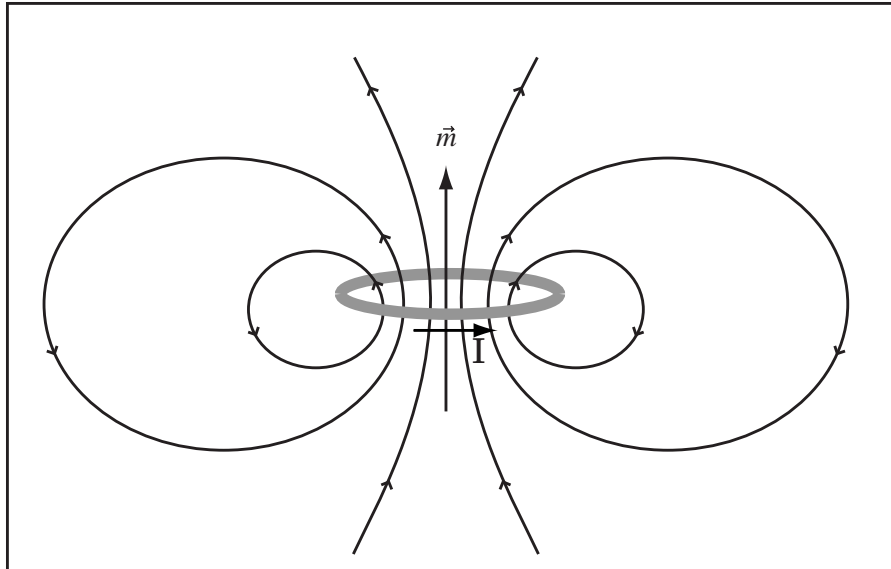

Definition of Dipole Moment:

The magnetic dipole moment, \vec{m} , of a flat current loop is

$$\vec{m} = NIA\hat{n}$$

where I is the current in the loop, A is the cross-sectional area inside the loop, N is the number of turns, and \hat{n} is a unit vector normal to the surface enclosed by the loop with orientation chosen so that when the thumb of your right hand points in the direction of \hat{n} , your fingers curl in the direction I flows.

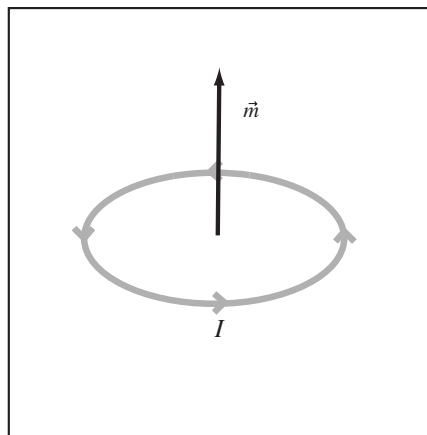

Dipole of a Permanent Magnet: The magnetic dipole moment of a permanent magnet points from the South Pole to the North Pole through the magnet.

Field Map of a Permanent Magnet: The field of a permanent magnet is drawn below. Note that the field lines close within the magnet.

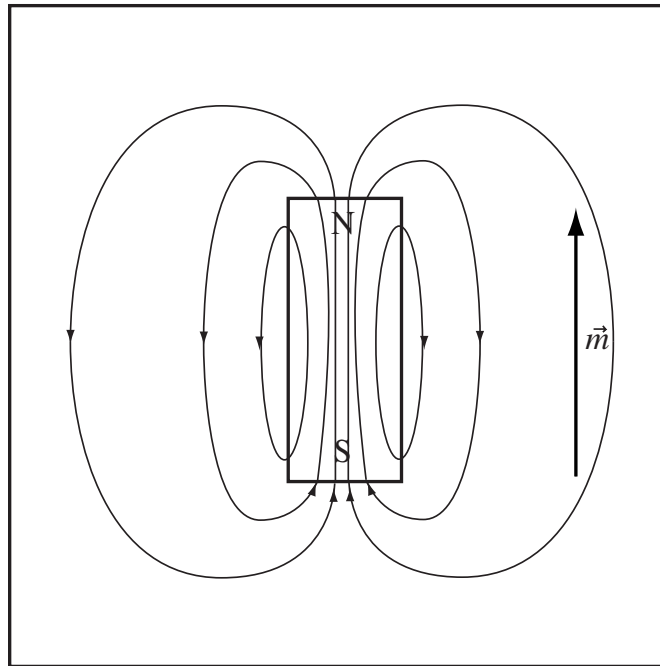

Example 29.1 Drawing Magnetic Field Lines of a Permanent Magnet

Problem: Two identical permanent magnets are placed near each other so that the long sides are parallel and the North pole end of the first is beside the South pole end of the second. Draw the magnetic field map for this configuration.

Solution

Strategy: Draw field stubs for North and South poles, then connect the field lines both outside and inside the magnet.

(a) Draw the Field in the Magnet: Draw field line stubs leaving the North pole end of the magnet and entering South pole end of the magnet. The lines should extend through the magnet.

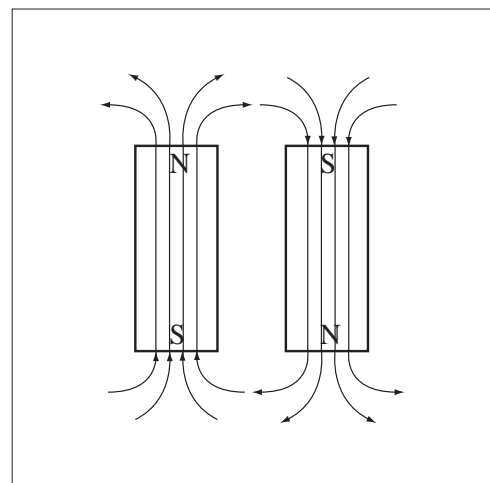

(b) Draw Field Map: Using the same technique used to draw electric field lines for fixed charge, draw a field map outside of the magnets by connecting and smoothly bending the line stubs. Connect the field lines between the magnets since the field lines point in the same general direction where they would (but cannot) intersect.

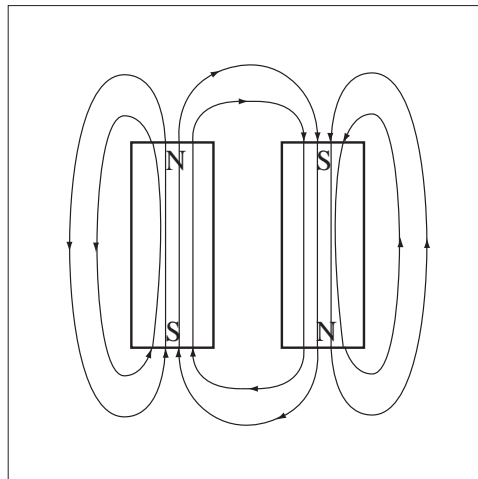

29.1.2 Quantitative Form of Magnetic Dipole Field

As I write down the quantitative form of the magnetic field of a point dipole, the field far from the dipole, you should experience *deja vu*. All the formulas for magnetic dipoles will be the same as the formulas for electric dipoles. So this is something you already have experience with.

Magnetic Dipole Field: The full mathematical form of the field of a magnetic dipole, \vec{m} is:

$$\vec{B}(\vec{r}) = \frac{\mu_0}{4\pi} \frac{3\hat{r}(\vec{m} \cdot \hat{r}) - \vec{m}}{r^3}.$$

This is the field of a point dipole or the field far from a system with a magnetic dipole moment.

If we chose the $+\hat{y}$ direction as the direction of the magnetic dipole, we can calculate the magnetic field along the x and y axis.

Simplified Magnetic Dipole Fields: The expression above for the magnetic dipole field can be simplified if a direction for the dipole moment is chosen and only the strength of the field along the axes is computed. If $\vec{m} = m\hat{y}$, then along the $+\hat{y}$ axis,

$$\vec{B}(0, y, 0) = \frac{\mu_0}{4\pi} \frac{2m\hat{y}}{|y|^3}.$$

and along the x -axis

$$\vec{B}(x, 0, 0) = -\frac{\mu_0}{4\pi} \frac{m\hat{y}}{|x|^3}$$

29.2 Behavior of Dipoles in Magnetic Fields

29.2.1 Rotation of Magnetic Moments in a Magnetic Field

We have experience with the behavior of magnetic moments in magnetic fields—a compass needle is a permanent magnet with the North pole in the direction the needle points—therefore, a compass needle has a magnetic moment. The needle points in the direction of the moment. A compass needle comes to rest pointing in the direction of the magnetic field lines, so a magnetic moment will rotate toward the direction of field and will come to rest (if there are losses in the system) pointing in the direction of the field.

Magnetic Dipole will Rotate to Align with Magnetic Field: A magnet dipole will rotate so the dipole moment points in the same direction as the field line. A compass needle is a magnetic dipole which rotates to align with the earth's magnetic field which points to the north.

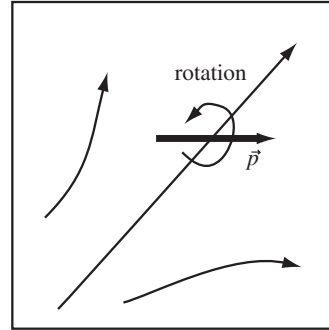

The magnetic moment of a permanent magnet depends on the shape and material of the magnet and must be measured in most cases.

Example 29.2 Rotation of Permanent Magnet in Magnetic Field

Problem: In the configuration of infinite straight wires and magnets at the right, the wires carry the same magnitude of current. The magnet rotates about its center whose location is fixed.

- Draw the magnetic field lines.
- Draw the orientation about its fixed center so that the magnet would come to rest, as if there was some force which slowed its motion.

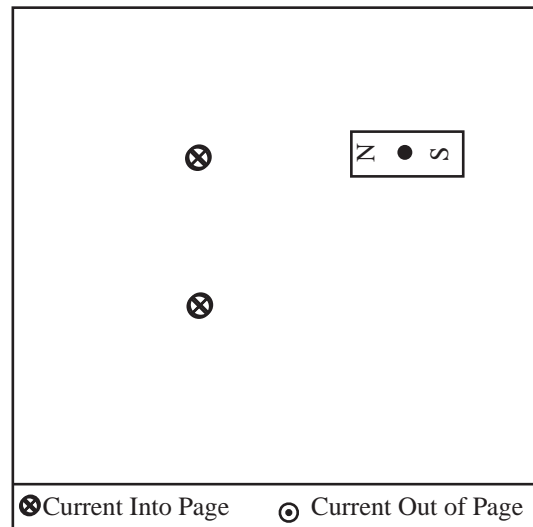

Solution to Part(a)

Draw the magnetic field using the techniques of last chapter.

Solution to Part(b)

The magnet will rotate so the north pole points along the field, that is so the magnetic moment aligns with the field.

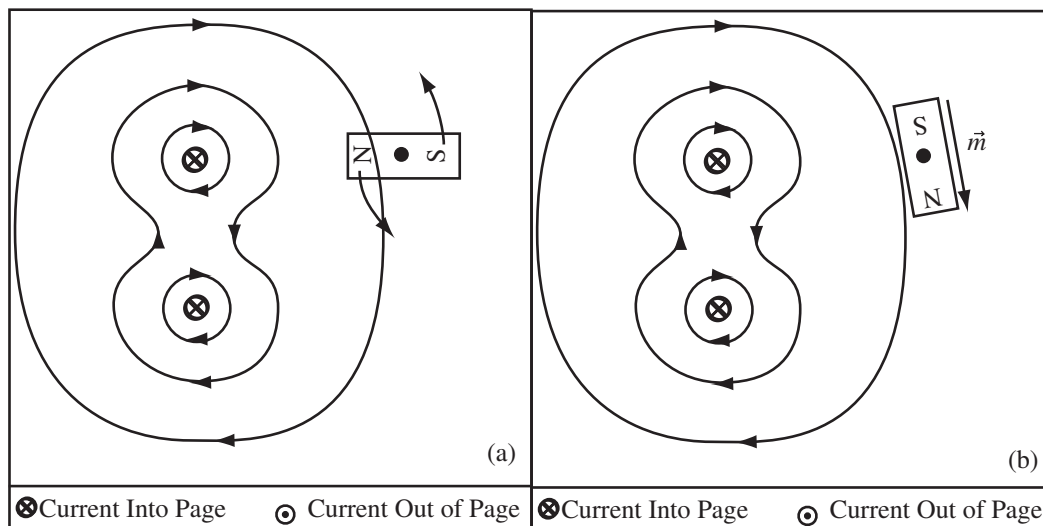

A coil carrying a current also has a magnetic moment. You can use the right-hand rule for magnetic moments to determine the direction of the moment OR use the right-hand rule for a wire to figure out what the field looks like, then figure out what direction the magnetic moment must point to produce the field.

Example 29.3 Rotation of Coil in Magnetic Field

Problem: The coil of wire in the figure is seen from the side. It carries current in the direction shown. The wire carries current into the page.

- (a) Draw the magnetic field map of the wire ignoring the field of the coil.
- (b) Indicate the initial direction of rotation of the coil.

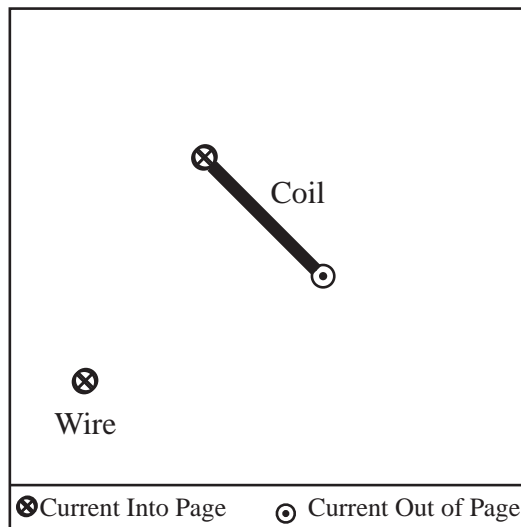

Solution to Part (a)

Use the right-hand rule to figure out the direction of the magnetic field. Point the thumb along the direction of the current and the fingers will curl in the direction of the field.

Solution to Part(b)

Initially, the coil will rotate so the magnetic moment rotates toward alignment with the magnetic field of the wire.

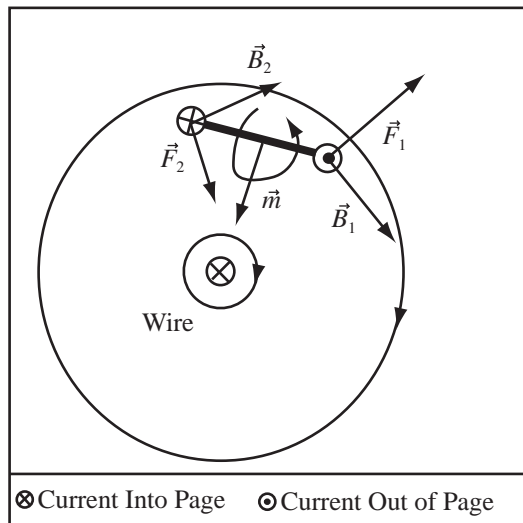

29.2.2 Torque and Potential Energy of a Magnetic Dipole

We can do better than just predicting the direction of rotation of the current loop or permanent magnet, we can compute the torque on it. Torque, represented by the vector, $\vec{\tau}$, is defined as

$$\vec{\tau} = \sum \vec{r}_i \times \vec{F}_i$$

where \vec{r}_i is a vector pointing from the center of mass of an object (or the point where it is pivoted) to the point where the force \vec{F}_i is applied. If an object has net torque applied to it, its speed of rotation will increase. If an object is not rotating, then the net torque on the object is zero.

Torque on a Magnetic Moment in Magnetic Field: The torque on an object with magnetic moment \vec{m} from a magnetic field, \vec{B} , is

$$\vec{\tau} = \vec{m} \times \vec{B}.$$

Direction of Rotation Due to Torque : If you grab the torque vector with your right hand and point your thumb along the vector, your fingers will curl in the direction that the object is angularly accelerated, or in the direction that it would rotate if it started from rest.

Since an external agent has to exert a torque to rotate a magnet in a magnetic field away from its equilibrium position, the magnet's potential energy changes as it is rotated. The form of the magnetic potential energy is very similar to the electric potential energy of a dipole in an electric field.

Magnetic Potential Energy of a Dipole: The potential energy, U , of a dipole with dipole moment \vec{m} in a magnetic field \vec{B} is

$$U = -\vec{m} \cdot \vec{B}$$

First, let's do something that does not require us to understand torque mechanically just to get our feet wet.

Example 29.4 Torque on a Current Loop

Problem: A uniform magnetic field $\vec{B} = 0.5\text{T}\hat{z}$ fills space. A loop makes an angle of $\theta = 120^\circ$ to the field. The loop is a circle with radius 15cm carrying a current of 100mA with orientation as shown in the diagram.

- What is the magnitude of the magnetic moment of the loop?
- What is the torque on the loop?
- Sketch the direction of rotation.

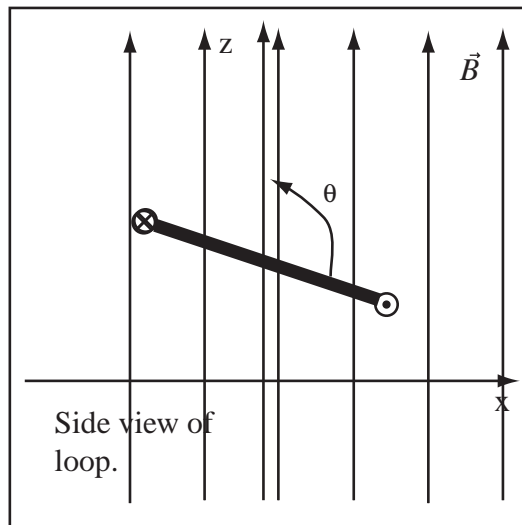

Solution to Part(a)

The magnetic moment of a current loop is defined as $\vec{m} = NIA\hat{n}$ where N is the number of turns, \hat{n} is the normal, I is the current, and $A = \pi r^2$ is the area of the loop with radius r . Substituting gives,

$$|\vec{m}| = (1)(0.1\text{A})(\pi)(0.15\text{m})^2 = 0.0071\text{Am}^2$$

Solution to Part(b)

The direction of the magnetic moment is normal to the loop, \hat{n} , as shown below. The direction is found by curling your fingers in the direction of the current, using your right hand. Your thumb will point in the direction of the normal. From the diagram below, you can see the normal makes an angle of $\theta_n = 120^\circ + 90^\circ = 210^\circ$ with the field. The torque on a current loop is given by $\vec{\tau} = \vec{m} \times \vec{B}$. Using the right hand rule, the direction of the torque is into the page, which is the $-\hat{y}$ direction. The magnitude of the torque is

$$\tau = mB \sin \theta_n = (0.0071\text{Am}^2)(0.5\text{T})(\sin(210^\circ)) = 0.0018\text{Nm}$$

Solution to Part(c)

The rotation is shown to the right.

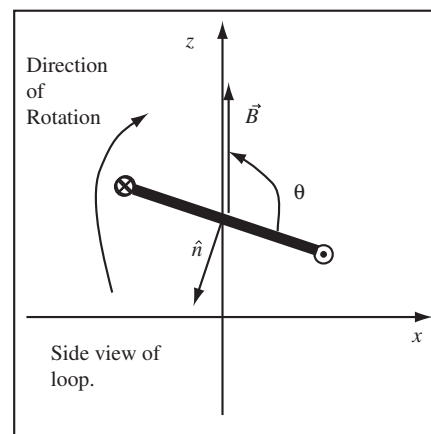

Now, let's use the magnetic torque to do something, like lift a weight.

Example 29.5 Torque on a Current Loop

Problem: A square (side length $d = 10\text{cm}$) coil of wire with 50 turns of wire carries a current of $I = 2\text{A}$. The coil's normal is perpendicular to a magnetic field of strength $B = 0.1\text{T}$ directed parallel to the Earth's surface. How much mass must be attached to one end of the coil to prevent it from rotating?

Solution

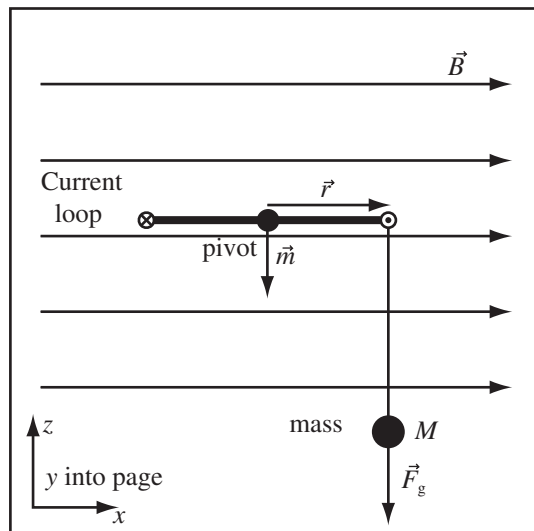
Definitions

- $\vec{m} \equiv$ Magnetic Moment of Loop
- $I \equiv$ Current in loop
- $M \equiv$ Mass of Object hung from Loop
- $\vec{F}_g \equiv$ Force of Gravity
- $\vec{\tau}_g \equiv$ Torque Due to Gravity
- $\vec{\tau}_m \equiv$ Torque Due to Magnetic Field
- $N = 50 \equiv$ Number of Turns of Wire

Strategy: Balance the torque due to gravity against the torque applied by the hanging weight.

(a) Compute the Magnetic Moment of the Loop: The magnitude of the magnetic moment of a current loop is the current multiplied by the area. The direction of the magnetic moment is found by curling your fingers in the direction of current and your thumb points in the direction of the moment. Therefore, the magnetic moment of our current loop is

$$\vec{m} = NId^2(-\hat{z}).$$

(b) Compute the Torque Due to the Magnetic Field: The torque due to a magnetic field, $\vec{B} = B\hat{x}$ is

$$\tau_m = \vec{m} \times \vec{B} = NId^2(-\hat{z}) \times (B\hat{x}) = -NIBd^2\hat{y}$$

using the right-hand rule. The torque points out of the page, so the loop would tend to rotate in the direction that your fingers curl, if your thumb points in the direction of the torque—counterclockwise. (Notice that this will always give you the same direction as the shortest distance from \vec{m} to \vec{B} .) This rotation is balanced by a mass hanging from the loop.

(c) Compute the Torque Due to Gravity: The vector from the center of the loop to the edge is $\vec{r} = \frac{d}{2}\hat{x}$ and the force of gravity is $\vec{F}_g = -Mg\hat{z}$, so the torque due to gravity is

$$\vec{\tau}_g = \vec{r} \times \vec{F}_g = \frac{d}{2}\hat{x} \times (-Mg\hat{z}) = \frac{dMg}{2}\hat{y}$$

using the right-hand rule.

(d) Balance the Torques: If the loop does not rotate, then the total torque is zero so

$$\vec{\tau}_g + \vec{\tau}_m = 0 = \frac{dMg}{2}\hat{y} - NIBd^2\hat{y}$$

Solve for M ,

$$M = \frac{2NIdB}{g} = \frac{2(50)(0.1\text{m})(2\text{A})(0.1\text{T})}{9.81\frac{\text{m}}{\text{s}^2}} = 0.2\text{kg}$$

which is pretty good.

29.2.3 Motion of Dipole in Non-Uniform Field

The first part of this section dealt with the rotation of magnetic dipoles in a magnetic field. You all observed this as you let the red and green lab magnets rotate in their stands and saw that their poles and thus the magnetic moments aligned.

Equilibrium Alignment of Magnetic Moments: In equilibrium, the magnetic moments of a set of permanent magnets point in the same direction. In this orientation, the moments are said to align.

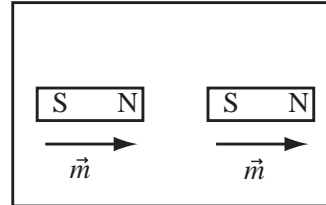

You also saw that one magnet attracted another magnet, if their poles were aligned. The magnets repelled if the poles were anti-aligned. Torque was discussed first, because it is actually the primary (highest order) effect of a magnetic field on a dipole. Unless the field is non-uniform, there is no magnetic force on a dipole.

Uniform Magnetic Field Exerts Zero Net Force on a Magnetic Dipole: If the magnetic field is uniform and the same at all points in space, the net magnetic force on a magnetic moment is zero.

Therefore, if we are discussing the repulsion or attraction of magnetic moments, we are discussing non-uniform fields. Our experience with the attraction or repulsion of permanent magnets can be used to predict the behavior of magnetic moments in non-uniform fields. Recall:

Aligned Magnets Attract: If the magnetic moments of permanent magnets are aligned, the magnets attract one another.

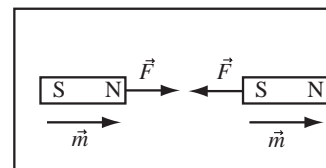

Anti-aligned Dipoles Repel: If the magnetic moments are anti-aligned (point in opposite directions) the moments repel.

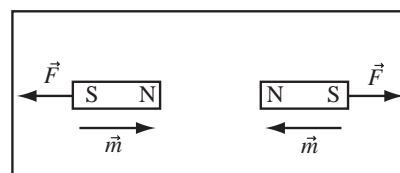

With these rules in mind, all we have to do to understand the motion of a dipole in a magnetic field is to replace one of the magnets with the field it produces.

Aligned Dipole is Attracted to Region of Stronger Field: If the magnetic moment of a permanent magnet or coil points in the same direction as the magnetic field, it will feel a force toward increasing magnetic field strength as shown in figure (a) below. One can deduce this by imagining a permanent magnet producing, as shown in figure (b), the field and using the fact that like poles repel/unlike poles attract.

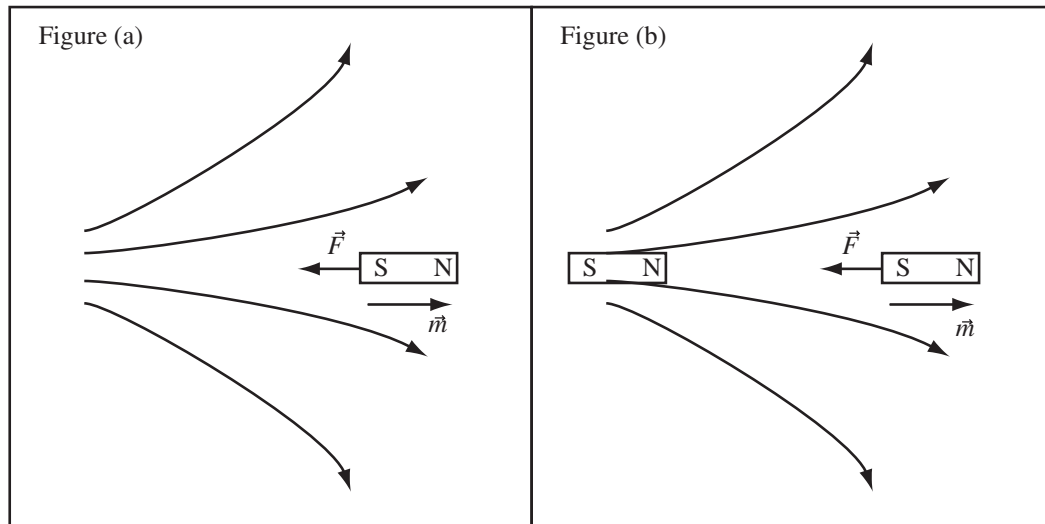

Anti-aligned Dipole Feels Force Toward a Weaker Field: If the magnetic moment of a permanent magnet or coil points in the opposite direction to the magnetic field, it will feel a force toward decreasing magnetic field strength, as shown in figure (a) below. This can be deduced by imagining a permanent magnet that could produce the field, figure (b), and then using the properties of magnets.

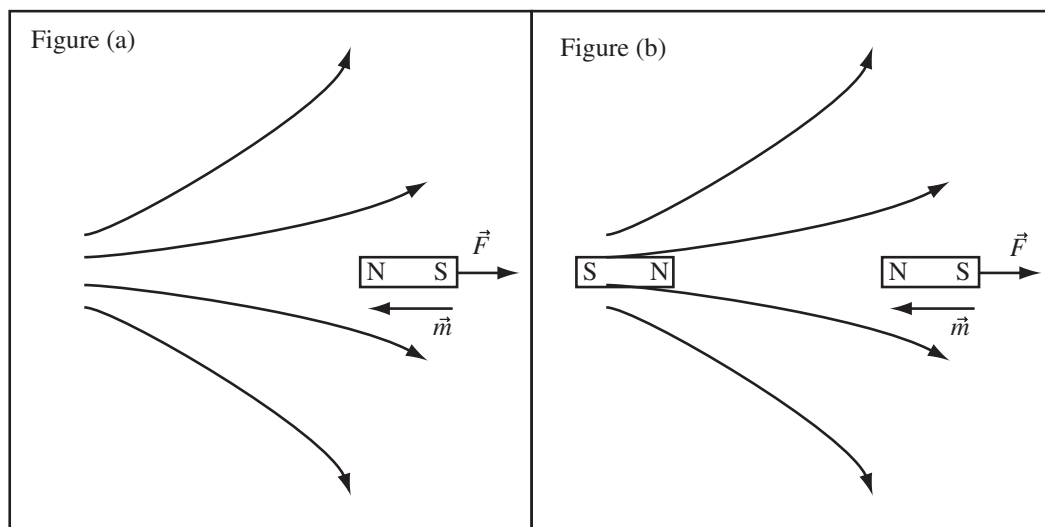

Example 29.6 Floating Bar Magnets

Problem: Two cylindrical bar magnets are placed in a tube that prevents them from rotating. The tube points vertically upward. What orientation must the dipoles of the permanent magnets have, so that one magnet floats

above the other?

Solution

For two permanent magnets to repel, the moments must anti-align. So for the magnetic force, \vec{F}_m , to balance the gravitational force, \vec{F}_g on the top magnet, the poles of the magnet must be as shown or both reversed so the two North poles are together.

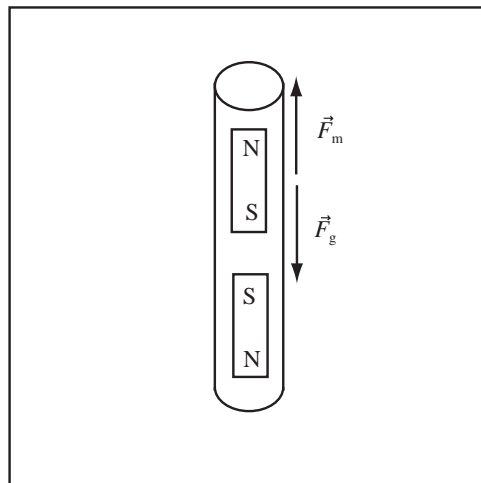

Example 29.7 Force of Current Loop on Magnet

Problem: A current loop carries current in the direction shown to the right. What is the direction of the force exerted by the magnetic field of the loop on the permanent magnet?

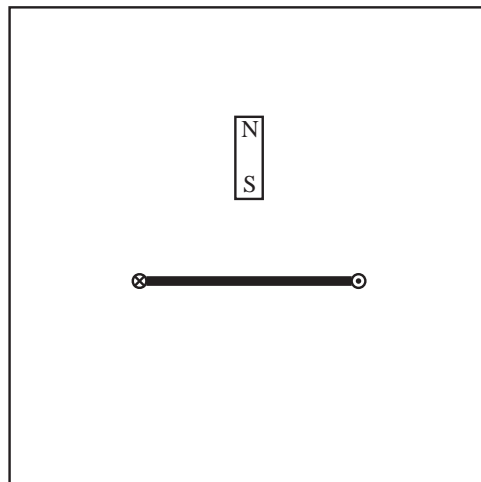

Solution

(a) Use either the right hand rule for a wire or the magnetic moment of the current loop to figure out the direction of the field. The magnetic moment of the permanent magnet points in the opposite direction of the magnetic field (at the magnet); therefore, the magnet is repelled from the region of strongest field and is pushed toward weaker fields. The force, therefore, points upward.

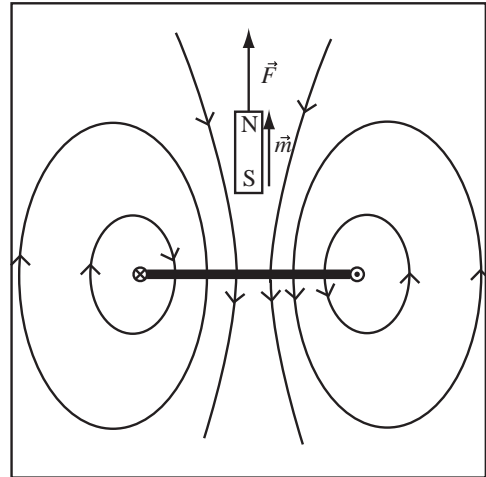

(b) A usual, we can also deduce the direction of the force by imagining the field was produced by a permanent magnet as shown to the right and using the fact that a north pole will repel a north pole.

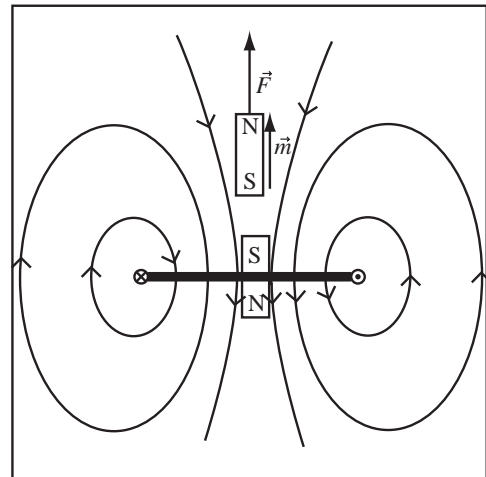

The magnitude of the force is given by an expression similar to the one used to find the force an electric field exerts on an electric dipole.

Force of Magnetic Field on a Magnetic Dipole: The net force on a magnetic dipole with dipole moment \vec{m} in a magnetic field that points in the \hat{y} direction, $\vec{B} = B(y)\hat{y}$, is

$$F_{net} = m \frac{dB}{dy} (\cos \theta)$$

where θ is the angle between the dipole moment vector and the y axis.

Chapter 30

Magnetic Materials

30.1 Introduction to Magnetic Materials

30.1.1 Magnetic Response of Materials

We know that the north end of a magnet is attracted to the south end of another magnet. We also know that a magnet will stick to a non-magnetic refrigerator, so the magnet must induce a magnetic moment on the refrigerator in the orientation drawn. If the magnetic moment induced on the refrigerator was in the opposite orientation, the magnet would be repelled from the refrigerator.

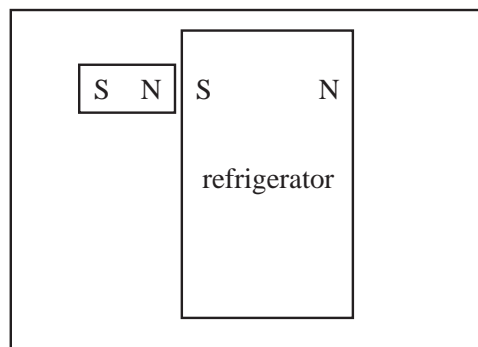

It seems reasonable that the total magnetic moment of either a permanent magnet or the temporary magnetic moment of the refrigerator depends on the size of the magnet or the amount of the refrigerator that is magnetized. Since the total magnetic moment of the material, \vec{m} , depends on the amount of material, it makes sense to define a magnetic moment density.

Magnetization: The magnetization density or simply the magnetization, \vec{M} , of a material is the magnetic dipole moment per unit volume,

$$\vec{M} = \frac{\vec{m}}{V}$$

where \vec{m} is the magnetic moment of the material and V is its volume.

If we have a large volume of a material that has a magnetization \vec{M} and we are far from the ends of the material the total magnetic field in the material is:

Field of a Magnetized Material without Applied Field: If there is not an applied field, in the interior far from the surface of a material with magnetization \vec{M} the magnetic field is

$$\vec{B} = \mu_0 \vec{M}$$

The above is the case for a permanent magnet; it has a magnetization without applying an external magnetic field. If we place any material in an external field, there will be a magnetic response producing a magnetization \vec{M} . The field due to this magnetization must be added to the external field to yield the total field in the material.

Magnetic Field in Material in an External Field: The magnetic field, \vec{B} , in a material with magnetization \vec{M} in an external applied field \vec{B}_0 is

$$\vec{B} = \vec{B}_0 + \mu_0 \vec{M}$$

We will find that for some materials the magnetization is in the same direction as the applied field and therefore the total field is greater than the applied field. For some materials, the magnetization is in the opposite direction as the applied field and the total field in the magnet is lower than the applied field. For materials with a weak magnetic response (what we will call paramagnetic and diamagnetic materials) there is an approximately linear relation between the magnetization and the applied field at low applied fields.

Magnetic Susceptibility: For many materials the magnetization, \vec{M} , is proportional to the applied field, \vec{B}_0 , the proportionality constant is the magnetic susceptibility, χ_m ,

$$\vec{M} = \chi_m \frac{\vec{B}_0}{\mu_0}$$

Relation Between Applied Field and Total Field for Linear Magnetic Materials: If a magnetic material has a linear relation between the applied field and the magnetization, that is if χ_m is constant, then the total field is related to the applied field by

$$\vec{B} = \vec{B}_0 + \mu \vec{M} = \vec{B}_0 + \chi_m \vec{B}_0 = (1 + \chi_m) \vec{B}_0 = K_m \vec{B}_0$$

where $K_m = 1 + \chi_m$ is called the relative permeability of the material.

From the above we can see the effect of a linear magnetic material is to increase the magnetic field by a factor of K_m . The analogous but opposite the effect of a linear dielectric material where the applied electric field is decreased by a factor of κ . K_m is the magnetic analogue of the electric κ . Unlike the dielectric constant, it is possible for $K_m < 1$, so a magnetic material can either increase or decrease the magnetic field.

Permeability and Permittivity of a Material: We have been working with the permittivity of free space, ϵ_0 , and the permeability of free space μ_0 . It is common practice to use the permeability of a material as $\mu = K_m \mu_0$ and the permittivity of the material as $\epsilon = \kappa \epsilon_0$.

30.1.2 Paramagnetism and Diamagnetism

For most materials, the magnetic response of the material is very small compared to the applied field and χ_m is constant for reasonable fields. The magnetic susceptibility, χ_m , can be either positive or negative. If $\chi_m > 0$, the induced dipole moment is in the same direction as the field and the material is said to be *paramagnetic*. If $\chi_m < 0$ the induced dipole is opposite the direction of the field and the material is said to be *diamagnetic*.

Type	Direction of Moment	Example	χ_m
Paramagnetic	same	Uranium	66×10^{-5}
Paramagnetic	same	Platinum	26×10^{-5}
Paramagnetic	same	Aluminum	2.2×10^{-5}
Paramagnetic	same	Sodium	0.72×10^{-5}
Paramagnetic	same	Oxygen	0.19×10^{-5}
Diamagnetic	opposite	Bismuth	-16.6×10^{-5}
Diamagnetic	opposite	Silver	-2.6×10^{-5}
Diamagnetic	opposite	Diamond	-2.1×10^{-5}
Diamagnetic	opposite	Lead	-1.8×10^{-5}
Diamagnetic	opposite	Copper	-1.0×10^{-5}
Diamagnetic	opposite	Superconductor	-1

For all normal paramagnetic and diamagnetic materials the effect is so small that it is difficult to observe. The value of χ_m is so small that when we tested copper and aluminum in lab we saw no magnetic response. A

permanent magnet will slightly attract a paramagnet and slightly repel a diamagnet. A superconductor is a perfect diamagnet, $K_m = 1 + \chi_m = 1 + (-1) = 0$ and reduces the magnetic field in its interior to zero. Therefore, a superconductor is strongly repelled from a permanent magnet which is why a superconductor floats over a permanent magnet.

30.2 Ferromagnetism

30.2.1 Ferromagnetism

Both diamagnetism and paramagnetism are small effects and can be understood in terms of the behavior of individual atoms. Ferromagnetism is an effect involving many atoms and in certain materials is a gigantic effect. Ferromagnetism arises when the atomic magnetic moments on different atoms tend to align with one another. This produces large regions involving billions of aligned moments called domains. When a field is applied, the domains align producing a large magnetization. This magnetization remains after the field is removed, producing a permanent magnet. Ferromagnetism occurs in only a few materials; iron, nickel, cobalt, and rare earth elements like gadolinium and dysprosium.

We can represent the process of magnetizing and then demagnetizing a ferromagnet by the curve to the right. The curve plots the applied field B_{app} against the resulting field in the material B . The material starts out at point (a) where there is zero applied field. As B_{app} increases the magnetic field in the material rapidly increases. The slope of the curve at point a is the initial relative permeability, $K_{m0} = B/B_{app}$. In ferromagnets, K_{m0} ranges from 200 to 10,000, so we get a lot of field in the ferromagnet for a small applied field. As the applied field is increased, the field in the magnet increases with a maximum slope of the curve between point (a) and (b) that ranges up to $K_m = 1,000,000$. The magnetic field in the material continues to increase until all the domains are aligned. When this happens the magnet is said to be saturated, and the magnetic field can no longer be increased by increasing magnetization. Saturation happens at point (b).

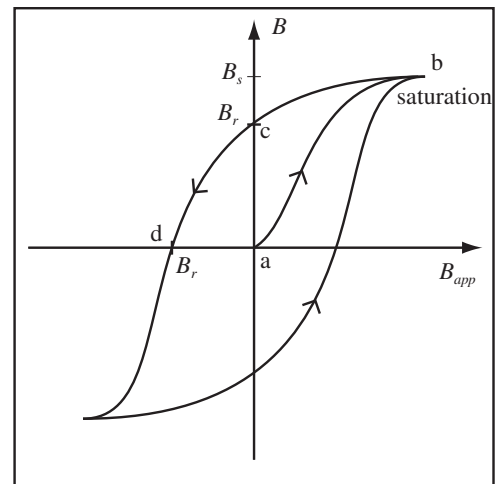

If we then start to turn off the applied field at the point (b), the magnetization decreases until the applied field is zero at point (c). There is still a magnet field at the point (c), called the remnant magnetic field B_r . This is the magnetic field of the ferromagnet acting like a permanent magnet. The ferromagnet does not return to its state of zero field when the applied field is removed. It remembers a field has been applied, it remembers its history. The curve captures this memory of history and is called a hysteresis curve. To erase this remnant magnetization, apply a field in the opposite direction until at point (d), the magnetic field drops to zero. The field we have to apply to remove the remnant magnetic field is called the coercive force, B_c . The coercive force is naturally not a force but a magnetic field.

The table below reports the magnetic properties of some important ferromagnetic materials. Note how small the coercive force, B_c , is compared to the remnant magnetization and how large the relative permeabilities are. This gives you an idea of how large a magnetic field you can produce for a small applied field.

Material	K_{m0}	K_m maximum	B_r	B_s	B_c
Iron Commercial 99.9%Fe	250	6000	1.3T	2.16T	8.8×10^{-5} T
Iron Pure 99.9%Fe	10,000	100,00	1.3T	2.16T	1.0×10^{-6} T
Permalloy	4,000	100,000	0.7T	1.05T	5×10^{-5} T
Superpermalloy	100,000	1,000,000	0.7T	0.79T	1.88×10^{-7} T
Cobalt 99% pure	70	250	0.5T		
Nickel 99% pure	110	600	0.4T		
Mu-metal	50,000	200,000			

Mu-metal is a material used for magnetic shielding. As you can see in the table for iron the ferromagnetic

properties of a material are very sensitive to the way the material is processed, which accounts for the difference between pure iron and commercial iron.

Example 30.1 Iron in a Magnetic Field

Problem: A field of $1 \times 10^{-5}\text{T}$ is applied to a bar of commercial iron, calculate the resulting magnetic field in the iron.

Solution

The field is much less than B_c so we can use the initial $K_m = K_{m0} = 250$, therefore the field is $B = K_m B_0 = (250)(1 \times 10^{-5}\text{T}) = 250 \times 10^{-5}\text{T}$

30.2.2 Commercial Magnetic Materials

The properties you want in a ferromagnet depends on what you want to use it for. If you want a ferromagnet to deliver magnetic flux somewhere or to act as a magnetic shield as we will investigate next section, you want a high relative permeability, K_m , but you do not want the material to stay magnetized after the external field is removed, so you want a low remnant field, B_r . For a permanent magnet, all you care about is the remnant magnetic field, the field that remains when the external field is removed. Commercial permanent magnets are usually made out of one of the materials in the following table:

Type	B_r	M
Neodymium Iron Boron(NdFeB)	1.28T	$1.02 \times 10^6 \text{ A/m}$
Samarium Cobalt(SmCo)	1.05T	$0.36 \times 10^6 \text{ A/m}$
Alnico - Aluminum Nickel Cobalt(AlNiCo)	1.25T	$0.995 \times 10^6 \text{ A/m}$
Ceramic	0.39T	$0.310 \times 10^6 \text{ A/m}$

The first two, NdFeB and SmCo, are called Rare Earth magnets. All these magnets are weird mixes of the elements given. The red and green lab magnets were Alnico and the small powerful nickel covered magnets were NdFeB. Unfortunately, the properties of magnetic materials depend greatly on the details of the manufacturing process and for the precise properties of a commercial permanent magnet you have to consult the manufacturer. There are naturally a number of other engineering parameters involved in the selection of the correct material to use for an engineering application; the coercive force, the field required to de-magnetize the material and the energy deposited in the magnet in a full magnetization cycle.

Example 30.2 Magnetic Field of Permanent Magnet

Problem: Some of the magnets we used to build speakers were Neodymium Iron Boron (NdFeB) and were cylinders with radius $r = 0.5\text{cm}$ and height $h = 1\text{mm}$.

Compute the magnitude of the magnetic field at a distance of 5cm along the axis of dipole.

Solution

(a) Compute the Magnetic Moment: The magnetic moment is the magnetization density multiplied by the volume

$$m = MV = \pi r^2 h M = \pi(0.005\text{m})^2(0.001\text{m})(1.02 \times 10^6 \text{ A/m}) = 0.08\text{Am}^2$$

(b) Compute the Magnetic Field: Far from the magnet, we can use the field of a point dipole. If the y axis is the axis of the dipole, along the axis of a point dipole,

$$B(0, y, 0) = \frac{\mu_0}{4\pi} \frac{2m}{|y|^3} = \frac{4\pi \times 10^{-7} \frac{\text{Tm}}{\text{A}}}{4\pi} \frac{2(0.08\text{Am}^2)}{(0.05\text{m})^3} = 1.28 \times 10^{-4}\text{T}$$

Example 30.3 Torque on Two Permanent Magnets

Problem: Two cylindrical Samarium Cobalt permanent magnets are 5cm apart. The magnets have radius 0.5cm and height 1mm . Compute the magnitude of the maximum torque one magnet can exert on one another.

Solution

(a) Compute the Magnetic Moment: The magnetization density of Samarium Cobalt is $M = 0.36 \times 10^6 \text{ A/m}$. The total magnetic moment is the magnetization density multiplied by the volume

$$m = MV = M\pi r^2 h = (0.36 \times 10^6 \text{ A/m})\pi(0.005\text{m})^2 0.001\text{m} \\ = 0.0283\text{Am}^2$$

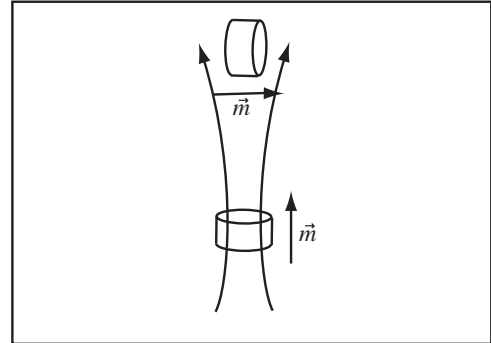

(b) Compute the Magnetic Field: The magnetic field of a dipole is strongest in the direction of the dipole moment. The magnitude of the magnetic field of a dipole at a distance y along its axis is

$$B = \frac{\mu_0}{4\pi} \frac{2m}{|y|^3} = \frac{(4\pi \times 10^{-7} \frac{\text{Tm}}{\text{A}})}{4\pi} \frac{2(0.0283\text{Am}^2)}{|0.05\text{m}|^3} = 4.52 \times 10^{-5}\text{T}$$

(c) Compute Maximum Torque: The torque a magnetic field exerts on a dipole is given by $\tau = \vec{m} \times \vec{B}$. The maximum torque occurs when the magnetic moment is at right angles to the field. This occurs for the orientation drawn above. At maximum torque, the magnitude of the torque is

$$|\vec{\tau}| = mB = (0.0283\text{Am}^2)(4.52 \times 10^{-5}\text{T}) = 1.28 \times 10^{-6}\text{Nm}$$

Chapter 31

Faraday's Law

So far we know how to work with systems where the electric or magnetic fields are constant. It would be natural to assume this would let us work with fields which are changing, by simply recalculating with the new currents or charges. Unfortunately, the universe is not that simple—changing fields cause additional effects.

31.1 Electromotive Force

31.1.1 Electromotive Force

Electromotive force is the work per unit charge to move a positive test charge along some path, usually in an electric circuit. When we were dealing with static charges, we called electromotive force “electric potential”. For moving charges or changing magnetic fields, that is no longer appropriate for reasons we will not go into. For our purposes, however, electromotive force behaves just like electric potential, in that if we connect a voltmeter across two points where there is an electromotive force between the points, we will read a voltage between the points. The electromotive force is the work done per unit charge as a charge is moved along a path C ,

$$emf = \frac{W}{q} = \frac{1}{q} \int_C \vec{F} \cdot d\vec{\ell} = \frac{1}{q} \int_C (q\vec{E} + q\vec{v} \times \vec{B}) \cdot d\vec{\ell} = \int_C \vec{E} \cdot d\vec{\ell} + \int_C \vec{v} \times \vec{B} \cdot d\vec{\ell}$$

where $d\vec{\ell}$ points along the path C and \vec{v} is the velocity of the path. The first term, $\int_C \vec{E} \cdot d\vec{\ell}$, is the emf that results from a net electric field along the path and is the negative of the potential difference if the field is generated by static charges. For static charges, if the path is closed this term is always zero because of independence of path. Changing magnetic fields can make this term non-zero for a closed path. The term, $\int_C \vec{v} \times \vec{B} \cdot d\vec{\ell}$, is a result of the path's motion through the magnetic field and is called the motional emf .

Definition Electromotive Force(EMF): The electromotive force, emf , around a stationary path, C , is the sum of the electric field along the path,

$$emf = \oint_C \vec{E} \cdot d\vec{\ell},$$

where the integral is taken around the path, \vec{E} is the electric field, and $\vec{\ell}$ points along the path. For electric fields due to static electric charges, this integral was always zero (for example, Kirchhoff's loop theorem). For paths within changing magnetic fields, this is no longer the case.

Definition of Motional Electromotive Force (Motional EMF): An *emf* can also result from the motion of a path through a magnetic field. The Lorentz Force $\vec{F} = q\vec{v} \times \vec{B}$ would exert a force on a positive charge moving with the path, say in a wire. The integral of the force per unit charge around the loop in this case is

$$emf = \int_C (\vec{v} \times \vec{B}) \cdot d\vec{\ell},$$

where $\vec{\ell}$ points along the path.

Example 31.1 EMF for Given Electric Field

Problem: The electric field, shown as the solid lines at the right, is produced by a changing magnetic field out of the page. Is the *emf* around the dashed path positive, negative, or zero?

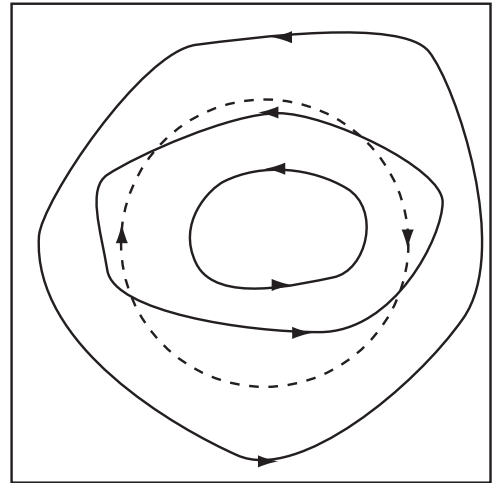

Solution

The electric field has a component in the opposite direction to the path all around the path, so the electric field adds along the path, and there is a negative *emf* around the path.

31.1.2 Drawing the Forces on the Charges in a Moving Wire

Conductors are full of electric charge (so are insulators, but their charge can't move). Therefore, if we pull a conductor which does not carry a current through a magnetic field, the electrons and protons that make up the wire become moving charge and feel a force due to the Lorentz force. The total force is zero, because the force on the protons is equal and opposite to the force on the electrons. The electrons can move and will move in response to an applied force. In some situations, which we will investigate this chapter, there is a net work per unit charge for a closed circuit, and therefore a charge going around the circuit gains energy each time around. In this case, there is a net *emf* and a flow of current around the circuit.

When we draw the *motional forces*, we draw the direction of the force on a positive charge. Remember, the direction of charge motion, in this case (as you apply the Lorentz force) is the direction that the coil is being dragged.

Example 31.2 Draw Motionally Induced Magnetic Force

Problem: A loop of wire is dragged through a uniform magnetic field in figure (a) and a magnetic field that is stronger for $x > 0$ than for $x < 0$ in figure (b). Draw the force the magnetic field exerts on the positive charges in the wire. Since current is defined as the flow of positive charge, this is the direction of the force that drives the current.

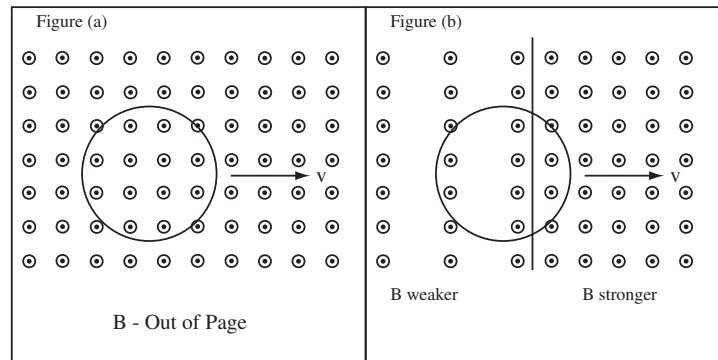

Solution

Consider what would happen to a positive charge at a few points in the circuit. The charge can't get out, so it's dragged along with the velocity of the circuit, \vec{v} . The charge, therefore, feels a force $\vec{F} = q\vec{v} \times \vec{B}$. In figure (a), these forces cancel if you take the integral around the loop, so there is no induced EMF—that is no work is done by the magnetic force as the charge is moved around the loop, so there will be no current. In figure (b), the sum of the forces around the loop is not zero and there will be a flow of current.

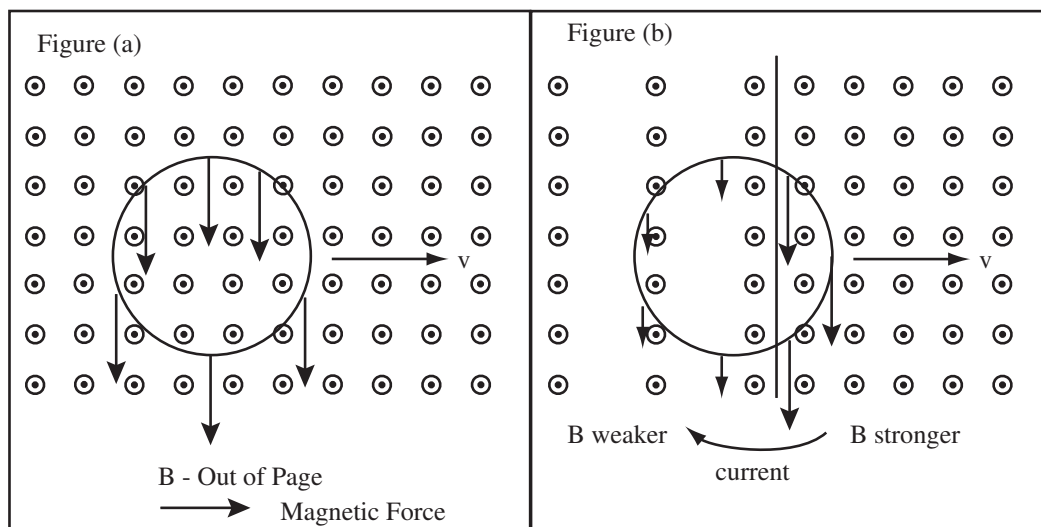

31.1.3 Calculating Motional EMF

We can use the definition of motional emf to calculate the voltage we would observe across a moving wire. If a wire of length L is electrically isolated as shown in figure (a) below, then the electromotive force will do work on positive charges in the wire causing a region of positive charge to form at one the end of the wire and a region of negative charge at the other end of the wire. Since the charges have nowhere to go, the electric field of the separated charge balances the magnetic force, $q\vec{E} = q\vec{v} \times \vec{B}$ or $E = vB$. A potential difference of $\Delta V = EL = vBL$ then exists across the wire. If the wire is connected to an electrical circuit (shown as a resistor), so that a current can flow a voltage (emf) will be observed

$$emf = N \int \vec{v} \times \vec{B} \cdot d\vec{\ell} = NvBL$$

where in this case $N = 1$ and L is the length of the wire in the field.

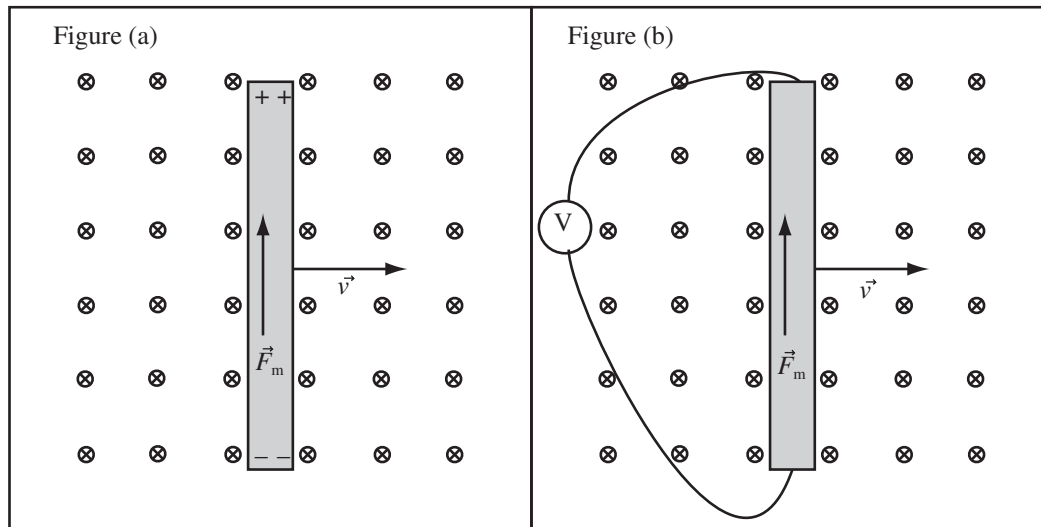

Example 31.3 Calculate Motional EMF for a Moving Loop

Problem: A square coil of wire 10cm on a side with 100 turns and sides parallel to the coordinate axis moves in the $x - y$ plane with velocity $\vec{v} = 10\frac{\text{m}}{\text{s}}\hat{x}$. Initially, the center of the coil is at the origin. A magnetic field $\vec{B}_- = -0.2\text{T}\hat{z}$ for $x < 0$ and $\vec{B}_+ = 0.2\text{T}\hat{z}$ for $x > 0$ is normal to the coil. The total resistance of the loop is 0.1Ω .

- Draw the magnetic force on the positive charges in the coil.
- What is the direction of the current flow?
- Calculate the *emf* around the loop.
- Calculate the current in the loop.

Solution to Part (a)

Use Lorentz Force: Use $\vec{F}_m = q(\vec{v} \times \vec{B})$. A positive charge moving with the loop feels this force in all regions. The forces are found using the right hand rule and are drawn as vectors.

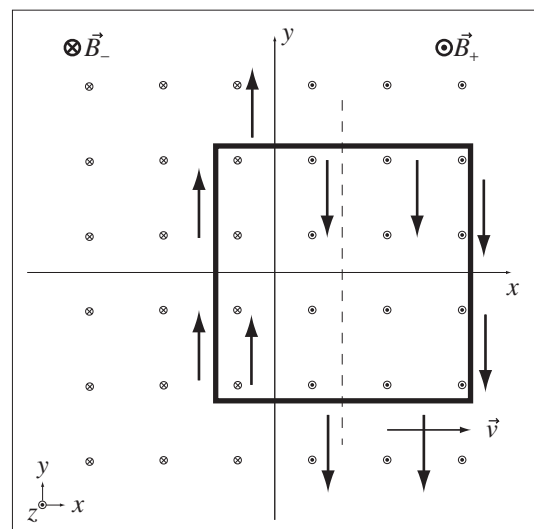

Solution to Part (b)

The forces on the top and bottom are perpendicular to the wire and can do no work along the direction of the wire. The forces on the left and right add to produce a clockwise EMF. A + charge has positive work done to it if it travels around the loop. Therefore a current will flow in the clockwise direction around the loop.

Solution to Part (c)

The electromotive force on the left side of the loop will drive the current in the clockwise direction and has magnitude

$$emf_{left} = N \int \vec{v} \times \vec{B} \cdot d\vec{\ell} = NvBL = (100)(10\frac{m}{s})(0.2T)(10cm) = 20V$$

The electromotive force on the right side also tends to drive the current in the clockwise direction and has the same magnitude as the emf on the left side. The total emf is the sum of the two

$$emf = emf_{left} + emf_{right} = 2emf_{left} = 40V$$

Solution to Part (d)

The current is found using Ohm's law,

$$I = \frac{emf}{R} = \frac{40V}{0.1\Omega} = 400A$$

Example 31.4 EMF Across Car

Problem: Your car is about 4m long, 1.5m wide, and 1.5m tall and you are driving east-west across Missouri along I-70 at 80mph = $36\frac{m}{s}$. For simplicity, assume the earth's magnetic field points directly north with magnitude $2.2 \times 10^{-5}T$. Compute the emf you would measure between your bumpers, the driver and passenger car door, and the roof and bottom of your car.

Solution

The motional emf for a moving conductor in a magnetic field is $emf = \int_C \vec{v} \times \vec{B} \cdot d\vec{\ell}$. Since the velocity and the magnetic field are perpendicular, $|\vec{v} \times \vec{B}| = vB$. If you are driving to the west, the direction of $\vec{v} \times \vec{B}$ is downward. Therefore, $\vec{v} \times \vec{B}$ is perpendicular to a path between the bumpers and to a path between the car doors, so the emf along these paths is zero. A path from the roof to the floor is parallel to $\vec{v} \times \vec{B}$ and the emf along the path is

$$emf = \oint \vec{v} \times \vec{B} \cdot d\vec{\ell} = vBl = (36\frac{m}{s})(2.2 \times 10^{-5}T)(1.5m) = 0.0012V = 1.2mV$$

an observable, but not particularly useful voltage. Do not worry about the sign. You would get the opposite sign if you assumed you were driving toward the east.

31.2 Magnetic Flux

While working with Gauss' law, we became familiar with the concept of electric flux. In applying the new physical law of this chapter, we will need to work with magnetic flux.

Definition of Magnetic Flux: The magnetic flux, ϕ_m , through a surface is defined the same way the electric flux is:

$$\phi_m = N \int_S (\vec{B} \cdot \hat{n}) dA,$$

where \vec{B} is the magnetic field, S is the surface, \hat{n} a normal to the surface, and dA an element of area of the surface, and N is the number of turns. If the magnetic field is constant, then the magnetic flux is $\phi_m = NA(\vec{B} \cdot \hat{n})$, where A is the area of the loop.

Units of Magnetic Flux: Flux is measured in Webers (Wb) where $1\text{Wb} = 1\text{Tm}^2$.

You can visualize the magnetic flux through a surface as the number of magnetic field lines passing through the surface.

Example 31.5 Field through Flat Loop

Problem: Our best UPII lab magnets produce a field of about 0.25T . Compute the magnetic flux due to this field if the direction of the field is parallel to the normal of a circular loop of wire 1cm in radius.

Solution

The magnetic flux through a loop of wire is $\phi_m = NBA$, if the field is parallel to the normal of the loop. Since the number of turns is not given, the number of turns is $N = 1$. The magnetic field is $B = 0.25\text{T}$, and $A = \pi r^2$ is the area of the loop. Substituting gives

$$\phi_m = NBA = NB\pi r^2 = (1)(0.25\text{T})(\pi)(1\text{cm})^2 = 7.9 \times 10^{-5}\text{Wb}$$

Example 31.6 Magnetic Flux through a Coil Tipped with Respect to the Field

Problem: A circular coil of wire with 20 turns of wire and radius 20cm has a normal which makes an angle of 20° with a uniform magnetic field of magnitude 0.25T . Compute the magnetic flux through the coil.

Solution

If the magnetic field is uniform, the magnetic flux is given by $\phi_m = NAB \cdot \hat{n}$, where $A = \pi r^2$ is the area, $N = 20$ is the number of turns, and $B = 0.25\text{T}$ is the magnetic field. We are given the angle the normal makes with the field as 20° , so $\vec{B} \cdot \hat{n} = B \cos 20^\circ$. Substituting gives

$$\phi_m = N\pi r^2 B \cos 20^\circ = (20)(\pi)(20\text{cm})^2(0.25\text{T}) \cos 20^\circ = 0.6\text{Tm}^2$$

Example 31.7 Magnetic Flux Through a Shrinking Loop

Problem: A circular loop of wire has a radius of 12cm at time $t = 0$. A $4.0\mu\text{T}$ magnetic field is perpendicular to the plane of the loop. The radius decreases at a rate of $3.0\frac{\text{mm}}{\text{s}}$.

- (a) What is the magnetic flux through the loop as a function of time?
 (b) What is the magnetic flux through the loop at $t = 2.0\text{s}$?

Definitions

$t \equiv$ Time in Seconds

$N = 1 \equiv$ Number of Turns

$A(t) = \pi R(t)^2 \equiv$ Area of Loop at Time t

$R(0) = 0.12\text{m} \equiv$ Initial Radius

$R(t) \equiv$ Radius at Time t

$\phi_m(t) \equiv$ Magnetic Flux at Time t

$\frac{dR}{dt} = -3.0\frac{\text{mm}}{\text{s}} \equiv$ Rate of Change of Radius

$B = 4.0\mu\text{T} \equiv$ Magnitude of Magnetic Field

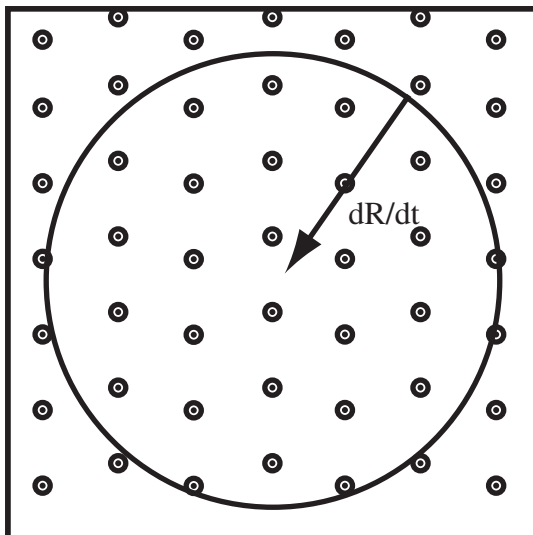

Strategy: Compute the flux as a function of time by writing the area as a function of time.

Solution to Part (a)

- (a) **Apply the Definition to Magnetic Flux:** Since the magnetic field is constant, the flux is $\phi_m = N\vec{B} \cdot \hat{n}A$.
 (b) **Compute the Dot Product:** The normal to the loop is parallel to the field, so $\vec{B} \cdot \hat{n} = |B|$ and $\phi_m = NBA$.
 (c) **Compute Time Dependent Area:** Since the radius is decreasing at 3mm/s ,

$$R(t) = R(0) - \left(\frac{dR}{dt}\right)t.$$

$$A(t) = \pi R^2(t) = \pi \left[R(0) - \left(\frac{dR}{dt}\right)t \right]^2$$

- (d) **Put it All Together:**

$$\phi_m(t) = NBA(t)$$

$$\phi_m(t) = \pi NB \left[R(0) - \left(\frac{dR}{dt}\right)t \right]^2$$

$$\phi_m(t) = \pi(4.0\mu\text{T}) \left[0.12\text{m} - \left(3\frac{\text{mm}}{\text{s}}\right)t \right]^2$$

Solution to Part (b)

Substitute $t = 2.0\text{s}$ and solve.

$$\phi_m(2.0\text{s}) = \pi(4.0\mu\text{T}) \left[0.12\text{m} - \left(3\frac{\text{mm}}{\text{s}}\right)2.0\text{s} \right]^2$$

$$\phi_m(2\text{s}) = 1.63 \times 10^{-7}\text{Wb}$$

31.3 Faraday's Law

31.3.1 Faraday's and Lenz' Law

In lab, we saw that when a coil of wire experiences a changing magnetic field, a potential difference is measured on a voltmeter connected across the coil. There is a general relation between a changing magnetic field and an electric field. For applications, we use this electric field to drive charge around a circuit, but the electric field is there even if the circuit isn't. The general relation between a changing magnetic field and the electric field is called *Faraday's Law*.

Qualitative Statement of Faraday's Law: If the magnetic flux through a closed path is changing, there is an *emf* induced around the path. The faster the flux changes, the larger the *emf*. The direction of the induced current is given by Lenz' law.

Lenz's Law: The induced emf and induced current are in such a direction as to oppose change in the magnetic flux.

Changing magnetic flux can be caused by a moving or distorting loop or a changing magnetic field. If the magnetic field is changing, the emf is caused by an electric field, so a changing magnetic field generates an electric field.

Example 31.8 How to Make Current in a Loop

Problem: A loop of wire is fixed in space. How can an EMF be induced in the loop?

Solution

By Faraday's Law, an emf can be induced in the loop by creating a changing magnetic flux, ϕ_m , through the loop. A changing magnetic flux can be created by the variation of the area of the loop, the orientation of the loop, the magnitude of the magnetic field, or the direction of the magnetic field; since $\phi_m = N \int_s \vec{B} \cdot n dA$. Since the loop must remain fixed, only the magnitude or orientation of the magnetic field can be changed. This can be done, for example, by moving a permanent magnet in a circular path around the plane of the loop.

We can also reason about the size and sign of the voltage we would measure across a loop experiencing a change in flux. Faraday's law states the faster the flux changes, the greater the voltage. Lenz' law gives the direction of the current that sets up a magnetic field, which resists the change in flux. If the direction of induced current is known, a potential difference can be selected to establish that current. How do we use Lenz' Law? Given a situation with changing flux through a loop, use the Right Hand Rule for a wire, grabbing the circuit and making sure your fingers curl so that the field IN the loop opposes the change in field. Your thumb points in the direction of the induced current. Select a sign for the voltage, remembering the current flows from high potential to low potential, so as to cause the current to flow in the correct direction.

Example 31.9 Direction of Current Flow

Problem: A square loop of wire sits in the $x - y$ plane. You have placed the loop in a constant magnetic field $\vec{B} = C\hat{z}$, $C > 0$. You can change the magnitude of the magnetic field by turning the knob on the magnet power supply. You want to induce a current in the clockwise direction as you look down on the loop from positive \hat{z} . Do you increase or decrease the magnitude of the field?

Solution

By Lenz' Law, current will be induced in a direction so as to oppose the change in magnetic flux. If the induced current is as drawn, the field of the induced current is into the page. This must oppose the change in the magnetic field, so we must increase the magnetic field.

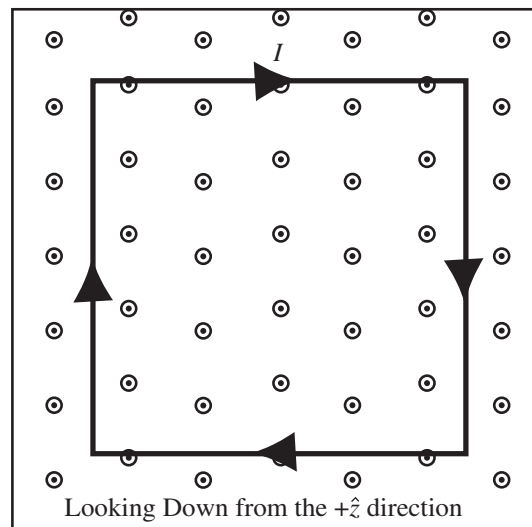

Example 31.10 Plotting EMF

Problem: A loop of wire is placed so that its normal is parallel to a magnetic field that is changing with time. The strength of the magnetic field is plotted to the right. Plot the emf induced in the loop.

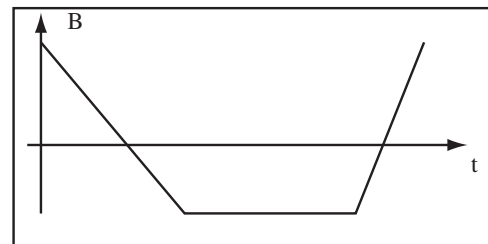

Solution

A emf requires a changing flux, so from point b to point c the emf is zero. By Lenz' law the emf resists the change in flux so a the decrease in flux from a to b causes a positive emf . The flux increases from c to d with twice the slope of the decrease from a to b, so the emf is positive from c to d and twice as big as the emf from a to b.

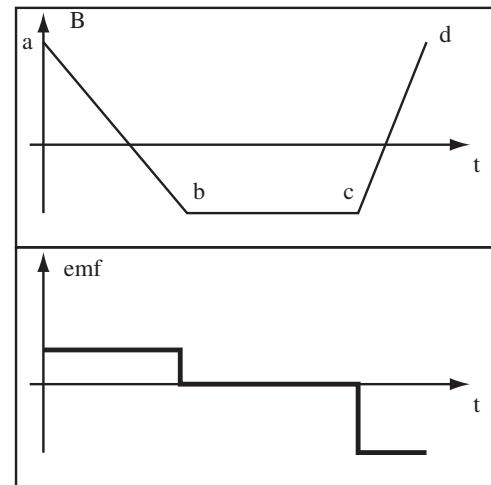

31.3.2 Drawing the Electric Fields Resulting From Changing Magnetic Fields

If a changing magnetic field is generating the emf , then the emf is caused by an electric field generated by the changing magnetic field. For simple systems, we can draw this electric field.

Example 31.11 Electric Field Due to Faraday's Law

Problem: A circular region of the $x - y$ plane contains a uniform magnetic field, which is decreasing in strength. Draw the electric field.

Solution

Since the magnetic field is changing, there is an electric field around any closed path through which the flux is changing. By the symmetry of the situation, the electric field lines must be circles. Lenz' Law tells us that if a circuit was placed in the electric field, current would flow to oppose the change in field. This current flow would be in the direction of the field lines, since the field lines point in the direction of the force on a positive charge. Since the magnetic field is decreasing, the current would produce a magnetic field in the direction of the existing field to oppose the change. Using the right hand rule for a wire on one of the field lines to find the required direction of current flow for the required field direction gives the direction of the electric field lines drawn.

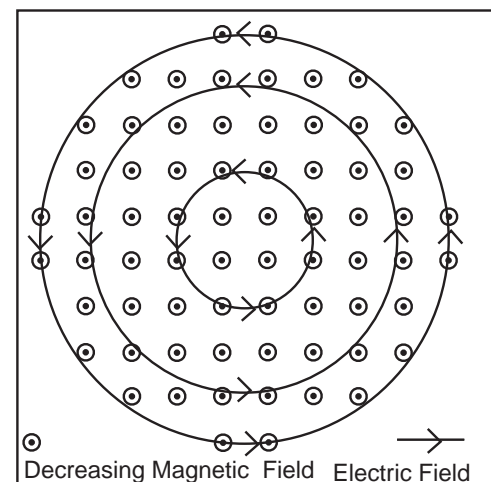

31.3.3 Eddy Currents

When a conductor experiences a changing magnetic field, an electromotive force is induced around any closed path in the conductor, which encloses a changing magnetic flux. This happens for solid conductors as well as loops. The emf induces currents around closed loops in the solid conductor. These currents are called *Eddy Currents*.

Eddy Currents : Eddy currents are currents induced in a solid piece of conducting material by a changing magnetic flux.

Consider the following case: a steel disk is thrown into a magnetic field. As it enters and leaves the field, there is a changing magnetic flux through the disk, inducing an emf , which causes a current to flow.

Example 31.12 Eddy Current in a Disk

Problem: A steel disk is thrown into a region of uniform magnetic field from a region of zero magnetic field. Sketch any induced currents as the disk enters the field.

Solution

As the disk enters the magnetic field, the flux through the disk changes, causing an emf around paths through the disk, by Faraday's law. Since the disk is conducting, this emf will cause a current to flow. The current direction will act to oppose the change in flux. The flux is increasing, so the current will circulate in a direction to produce a magnetic field opposite to the uniform field. I used the right hand rule for a wire to figure out the direction of the current flow to produce this opposing field. Once inside the uniform field, the flux is no longer changing, so eddy currents stop.

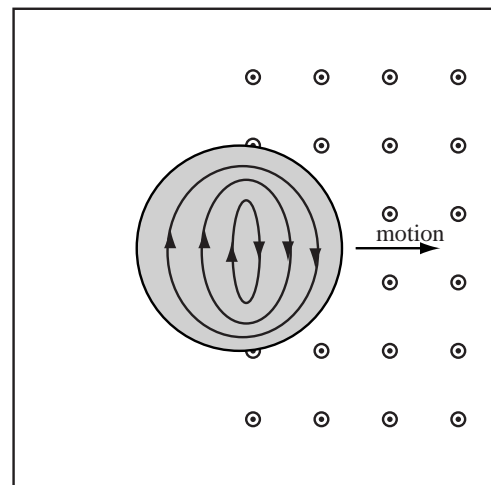

31.3.4 Quantitative Statement of Faraday's Law

In this section, we state the quantitative form of Faraday's law and do a bunch of examples.

Faraday's Law: For any closed path, C , the emf around the path is related to the magnetic flux through the surface, S , bounded by the path by

$$emf = -\frac{d\phi_m}{dt} = -\frac{d}{dt} \int_S \vec{B} \cdot \hat{n} dA,$$

that is, EMF equals the time rate of change of magnetic flux.

Faraday's Law for a Fixed Path: A changing magnetic flux through the surface enclosed by a stationary path causes a net electric field around the path,

$$emf = \oint_C \vec{E} \cdot d\vec{\ell} = -\frac{d\phi_m}{dt} = -\frac{d}{dt} \int_S (\vec{B} \cdot \hat{n}) dA,$$

where \vec{E} is the electric field, emf is the electromotive force, C is the path bounding the surface S , $\vec{\ell}$ points along the path, ϕ_m is the magnetic flux through the surface, \hat{n} is the normal to the surface, and t is the time.

Faraday's law allows us to extend the Maxwell equation relating to independence of path to systems with a changing magnetic field. All that is left to do to complete Maxwell's equations is to complete Ampere's law.

Maxwell's Equations Part III: Maxwell's Equations and the Lorentz force as introduced to this point are:

Maxwell's Equations

Gauss' Law $\int_S(\vec{E} \cdot \hat{n})dA = \frac{Q_{\text{enclosed}}}{\epsilon_0}$

No Magnetic Monopoles $\int_S(\vec{B} \cdot \hat{n})dA = 0$

Faraday's Law (Independence of Path) $\oint_C \vec{E} \cdot d\vec{\ell} = -\frac{d\phi_m}{dt} = -\frac{d}{dt} \int_S \vec{B} \cdot \hat{n}dA$

Ampere's Law $\oint_C \vec{B} \cdot d\vec{\ell} = \mu_0 I_C$ when there are no changing electric fields.

Lorentz Force

$$\vec{F} = q\vec{E} + q\vec{v} \times \vec{B}$$

The only thing left to do is finish Ampere's law.

31.3.5 Calculations using Faraday's Law

Computing the induced *emf* using Faraday's Law follows a simple pattern. First, compute the flux through the circuit as a function of time; second, take the derivative of the flux to get the *emf*; third, apply Lenz' Law to get the sign. The following examples illustrate computing the *emf* when the changing flux is caused by a changing field, a loop that is changing size, and a rotating loop.

Example 31.13 Compute Induced EMF for Changing Magnetic Field

Problem: A square coil of wire 10cm on a side with 100 turns sits in the $x - y$ plane. The coil resides in a magnetic field $\vec{B} = Ct^2\hat{z}$ that is changing with time. The constant $C = 0.1\text{T/s}^2$. Compute the induced EMF in the coil.

Solution

Definitions

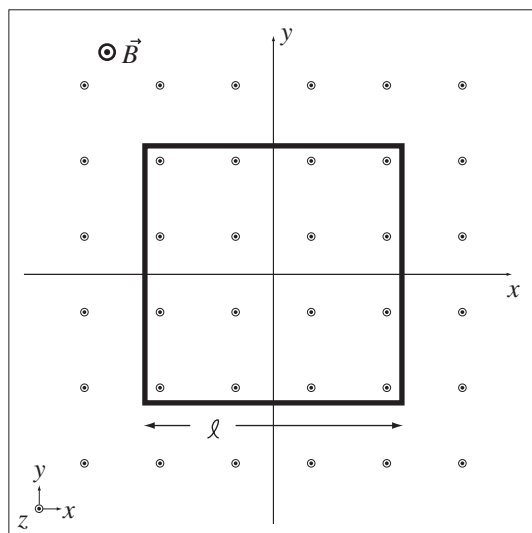

- $l = 10\text{cm} \equiv$ Length of one side of the square
- $N = 100\text{turns} \equiv$ Number of turns constituting the loop
- $\vec{B} = Ct^2\hat{z} \equiv$ Time-dependent magnetic field
- $\phi_m \equiv$ Magnetic flux through the loop
- $A \equiv$ Area of the loop
- $t \equiv$ Time

Strategy: Compute the flux through the loop, apply Faraday's Law to get the voltage, and Lenz' Law to get the sign.

(a) Compute the Flux: Since the magnetic field is uniform over the area of the loop and the loop is perpendicular to the field, the flux is $\phi_m = NBA = NB\ell^2$.

(b) Use Faraday's Law:

$$\begin{aligned} \text{emf} &= -\frac{d}{dt}\phi_m \\ &= -\frac{d}{dt}(NBA) = -\frac{d}{dt}(NB\ell^2) \end{aligned}$$

Only the magnetic field is time dependent, so

$$\text{emf} = -N\ell^2 \frac{d}{dt}B = -N\ell^2 \frac{d}{dt}(Ct^2) = -N\ell^2[2Ct] = -(0.2\text{T/s}^2)(100)(0.1\text{m})^2t = -0.2 \frac{\text{Tm}^2}{\text{s}^2}t$$

The sign of the EMF is related to the choice of direction the path traverses the circle, either clockwise or counterclockwise; the sign of the flux depends on whether the loop normal points into or out of the page. Needless to say, this involves another Right Hand Rule. Therefore, use Lenz' law to figure out the current direction.

(c) Use Lenz' Law: Since the magnetic field is increasing in the $+\hat{z}$ direction, the induced EMF will produce a current that produces a field, that points in the $-\hat{z}$ direction. By the right-hand rule, the current is clockwise as viewed from the $+\hat{z}$ direction.

Example 31.14 Compute Induced EMF for a Deforming Loop

Problem: A circular loop of wire has radius $R_0 = 10\text{cm}$ at $t = 0$. The radius is increasing at a rate of $v = \frac{dR}{dt} = 1\text{cm}$ per minute. The loop sits in the $x - y$ plane in a magnetic field $\vec{B} = -0.5\text{T}\hat{z}$. Compute the induced emf at $t = 0$.

Solution

Definitions

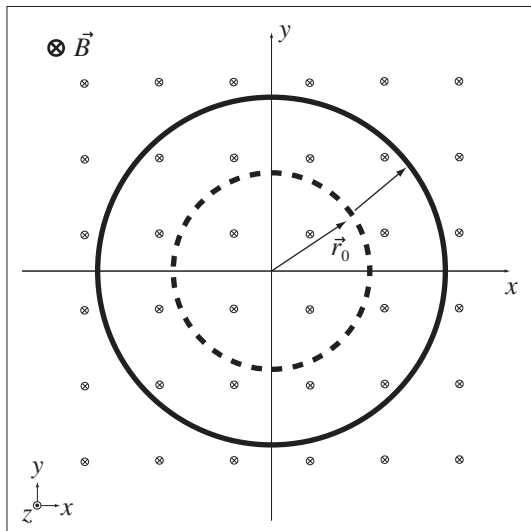

$$\vec{B} = -0.5\text{T}\hat{z} \equiv \text{Magnetic field}$$

$$v = dR/dt = 1\text{cm}/\text{min} \equiv \text{Rate of change of radius of the loop}$$

$$R_0 = 10\text{cm} \equiv \text{Initial radius of the loop}$$

$$\phi_m \equiv \text{Magnetic flux through the loop}$$

$$A \equiv \text{Area of the loop}$$

Strategy: Compute the flux as a function of time, apply Faraday's Law, then apply Lenz' Law to get the sign.

(a) **Compute the Flux:** Since the magnetic field is uniform over the surface bounded by the loop, the flux through the loop is $\phi_m = N(\vec{B} \cdot \hat{n})A$. The number of turns is not given in the problem so $N = 1$. Since the normal to the loop is in the same direction as the field, $\vec{B} \cdot \hat{n} = B$. The flux is then $\phi_m = BA(t)$ where the area of the loop has been written as a function of time. The loop is circular, therefore the area of the loop is $A(t) = \pi R(t)^2$. The radius $R(t)$ is changing with time and can be written

$$R(t) = R_0 + \frac{dR}{dt}t = R_0 + vt$$

where R_0 is the radius of the loop at time zero and v is the rate the radius is changing. Substituting everything back together yields

$$\phi_m = B\pi(R_0 + vt)^2$$

(b) Use Faraday's Law: The flux linking the circuit changes with time and therefore there is an induced EMF given by Faraday's Law.

$$\begin{aligned} emf(t) &= -\frac{d}{dt}\phi_m \\ &= -\frac{d}{dt}B\pi(R_0 + vt)^2 \\ emf(t) &= -2B\pi(R_0 + vt)v \end{aligned}$$

Evaluate this at $t = 0$

$$emf(0) = -2B\pi R_0 v = -2(-0.5\text{T})\pi(0.1\text{m})\left(\frac{0.01\text{m}}{60\text{s}}\right) = 0.052\text{mV} = 5.2 \times 10^{-5}\text{V}$$

(c) Use Lenz' Law: Since the loop is linking more of the magnetic field in the $-\hat{z}$ direction, the induced field will be one that points in the $+\hat{z}$ direction. By the right-hand rule, the current is counter-clockwise as viewed from the $+\hat{z}$ direction.

Example 31.15 Loop with Changing Magnetic Field

Problem: A square loop of width 5cm on a side and 50 turns lies in the $x - y$ plane. A uniform magnetic field $\vec{B} = 0.1\frac{\text{T}}{\text{s}^2}t^2\hat{z}$ is turned on starting at $t = 0$.

- Compute the magnetic flux linking the circuit as a function of time.
- Compute the EMF induced in the circuit as a function of time.
- Draw the system looking down at the loop from the $+z$ direction. Indicate the direction of the induced current.

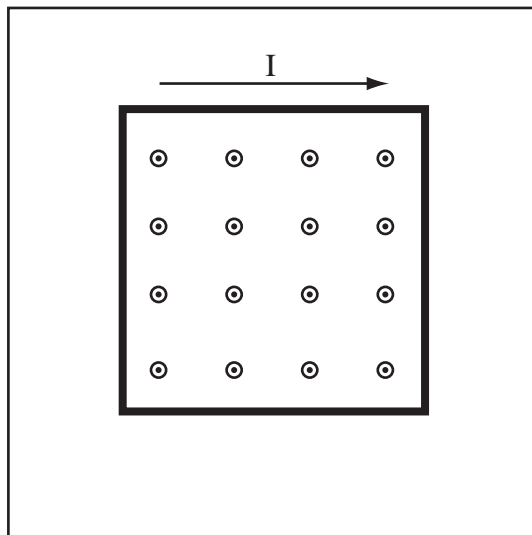

Definitions

$$\begin{aligned} \vec{B} &= 0.1\frac{\text{T}}{\text{s}^2}t^2\hat{z} \equiv \text{Magnetic Field} \\ \phi_m(t) &\equiv \text{Magnetic Flux} \\ A &\equiv \text{Area of Loop} \\ t &\equiv \text{Time} \\ N &= 50 \equiv \text{Number of Turns} \end{aligned}$$

Strategy: Compute the flux through the loop as a function of time, then apply Faraday's Law to compute the emf. Use Lenz' Law to compute the direction of the induced current.

Solution to Part (a)

Compute Magnetic Flux: Since the field is normal to the loop, the magnetic flux is defined as

$$\phi_m(t) = NAB(t) = (50)(5\text{cm})^2(0.1\text{t}^2\frac{\text{T}}{\text{s}^2}) = 0.0125\text{t}^2\frac{\text{Tm}^2}{\text{s}^2}$$

Solution to Part (b)

Compute EMF: Compute the emf using Faraday's Law,

$$emf = -\frac{d\phi_m(t)}{dt} = -0.0125 \frac{\text{Tm}^2}{\text{s}^2} \frac{dt^2}{dt} = -0.025t \frac{\text{V}}{\text{s}}$$

Solution to Part (c)

Apply Lenz' Law: The magnetic field is increasing in strength out of the page, therefore the magnetic flux out of the page is increasing. By Lenz' Law a current will be induced that creates a magnetic field to counteract the change in flux. The flux is increasing out of the page, so the induced field must point into the page. Using the right hand rule for a wire gives the induced current direction drawn.

31.4 Generators

A loop rotating in a magnetic field will produce an emf that is a sine wave. To evaluate the motion of the loop, we need to recall certain definitions about rotational motion and calculate the flux through a rotating loop.

Definition of Generator: A coil of wire in a magnetic field that is turned by some external power source in order to produce electricity.

Period of Rotation: The period of rotation, T , is the time it takes a rotating body to make one complete revolution.

Frequency of Revolution: The frequency of revolution f is the number of complete revolutions an object makes per second. It is equal to the inverse of the period

$$f = \frac{1}{T}$$

Units of Frequency: Frequency is measured in Hertz(Hz).

$$1\text{Hz} = 1\text{s}^{-1}$$

Angular Frequency: The angular frequency, ω , is the number of radians an object rotates per second,

$$\omega = 2\pi f$$

Example 31.16 Compute the Magnetic Flux Through a Rotating Loop

Problem: A circular loop turns once per minute in a 0.25T magnetic field on an axis perpendicular to the field. The loop has a radius of 10cm and 10 turns of wire. The normal of the loop is initially in the same direction as the field. Compute the flux as a function of time (in seconds).

Solution

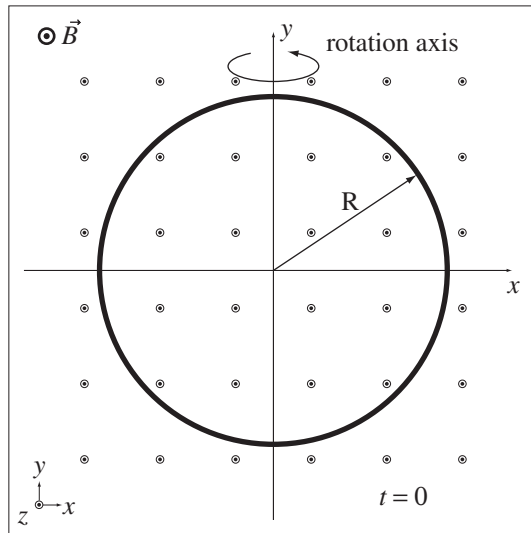

Definitions

- $B = 0.25\text{T} \equiv$ Magnitude of the magnetic field
 $R = 10\text{cm} \equiv$ Radius of loop
 $N = 10 \equiv$ Number of turns of the loop
 $\phi_m \equiv$ Magnetic flux through the loop
 $\phi_{max} \equiv$ Maximum magnetic flux through the loop
 $T = 1\text{min} \equiv$ Period of rotation
 $\omega \equiv$ Angular frequency of rotation

Strategy: Compute maximum flux, then use a cosine time dependence and fix the phase angle.

(a) Use Definition of Magnetic Flux: The magnetic flux for a coil in a uniform field is by definition

$$\phi_m = N(\vec{B} \cdot \hat{n})A$$

This can be re-written using a property of the dot product as

$$\phi_m = NBA \cos \theta$$

For a turning loop in a constant field the only thing changing with time in this expression is the angle the loop makes with the field, therefore θ is a function of time $\theta(t)$. The quantity NBA is the maximum flux, ϕ_{max} , through the loop which happens when the normal of the loop points in the same direction as the magnetic field.

$$\phi_{max} = NBA = NB\pi r^2 = (10)(0.25\text{T})\pi(10\text{cm})^2 = 0.0785\text{Wb}$$

(b) Write θ as a Function of Time: The function $\theta(t)$ gives the angle the normal makes with the field at all times. This can be written in terms of the angular velocity, ω , and the phase angle, δ .

$$\theta(t) = \delta + \omega t$$

Since the normal of the loop is perpendicular to the field at $t = 0$, $\theta(0) = 0 = \delta + \omega(0)$ therefore $\delta = 0$, and

$$\theta(t) = \omega t$$

(c) Compute Angular Frequency: Convert the period to seconds

$$T = 1\text{min} = 60\text{s}$$

The angular frequency is then

$$\omega = \frac{2\pi}{T} = \frac{2\pi}{60\text{s}} = 0.105 \frac{\text{rad}}{\text{s}}$$

(d) Put it All Back Together:

$$\phi_m(t) = \phi_{max} \cos(\omega t) = NB\pi r^2 \cos(\omega t)$$

$$\phi(t) = 0.0785\text{Wb} \cos\left[0.105 \frac{\text{rad}}{\text{s}} t\right]$$

Example 31.17 Maximum EMF of Generator

Problem: A circular coil with 200 turns has a radius of 1.5cm. It rotates in a uniform magnetic field $B = 0.10\text{T}$, so that at some point in the rotation, the normal to the loop is parallel to the field.

- (a) What should the frequency be in order to generate a maximum EMF of 10V?
 (b) If the coil rotates at 60Hz, what is the maximum EMF in the coil?
 (c) If the flux is maximum at $t = 0$, draw a well labelled plot of the output emf of the generator.

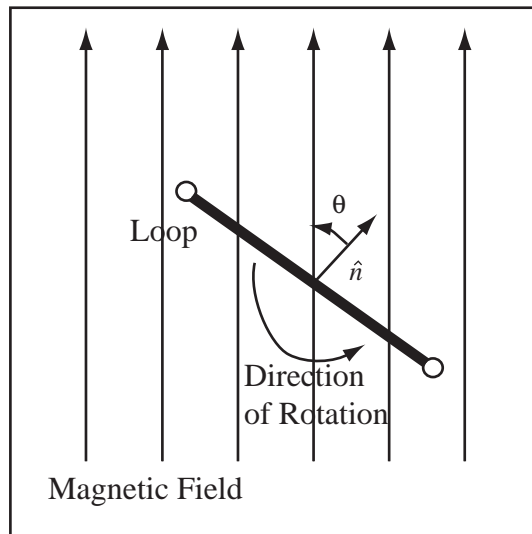

Definitions

- $\hat{n} \equiv$ Normal to Loop
 $A \equiv$ Area of Loop
 $B \equiv$ Magnetic Field
 $\omega \equiv$ Angular Frequency
 $t \equiv$ Time
 $f \equiv$ Frequency
 $emf_{max} \equiv$ Maximum Induced EMF

Strategy: Write magnetic flux as a function of time, then apply Faraday's Law to get the EMF.

Solution to Part(a)

(a) Compute Time Dependent Flux: The magnetic flux is $\phi_m = NAB \cdot \hat{n}$, if the field is uniform. The angle, θ , between the magnetic field and the loop is changing at a constant rate; this can be written as $\theta = \omega t$, where $\omega = 2\pi f$ is the angular frequency and f is the frequency. We can then write

$$\phi_m(t) = NAB \cdot \hat{n} = NAB \cos \theta = NAB \cos(\omega t)$$

This choice for the time dependence of θ assumes the angle between the loop normal and the magnetic field is zero at time $t = 0$.

(b) Apply Faraday's Law: The emf produced by the coil is given by applying Faraday's Law to the time dependent flux,

$$emf = -\frac{d\phi_m(t)}{dt} = -NAB \frac{d}{dt} \cos(\omega t) = NAB\omega \sin(\omega t).$$

The maximum emf occurs when $\sin(\omega t) = 1$, so

$$emf_{max} = NAB\omega = 2\pi fNAB.$$

(c) Solve for Frequency: We wish to compute the frequency at which the generator must turn to produce $emf_{max} = 10V$. Solving for the frequency gives

$$f = \frac{emf_{max}}{2\pi NAB} = \frac{10V}{2\pi(200)(\pi)(1.5\text{cm})^2(0.1T)} = 113\text{Hz}$$

Solution to Part (b)

Substituting into the expression derived in part (a), the maximum emf at $f = 60\text{Hz}$ is

$$emf_{max} = 2\pi fNAB = 2\pi(60\text{Hz})(200)(\pi)(1.5\text{cm})^2(0.1T) = 5.31V$$

Solution to Part (c)

The output emf is drawn to the right.

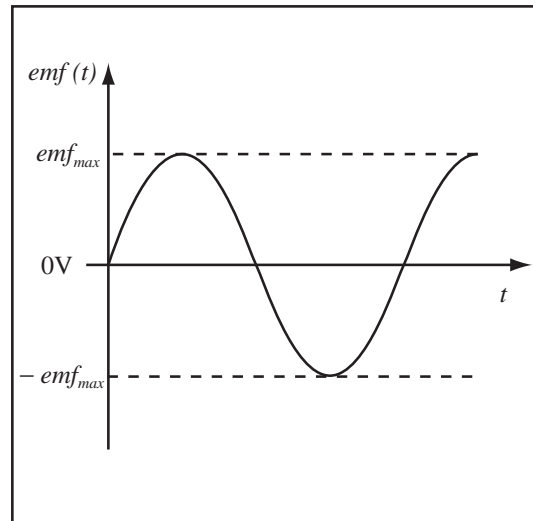

Almost all electrical power is produced by generators, spinning coils in magnetic fields.

Chapter 32

Inductance

32.1 Inductance

In electrostatics, a complex system of charge and field is reduced to a single parameter—the capacitance—when analyzing electric circuits. The magnetic properties of a system of conductors are reduced to a parameter called the *inductance*, when analyzing electric circuits. This inductance is the ratio of the flux through the circuit to the current flowing in the circuit. We can compute the inductance of a single circuit called the *self-inductance* or the inductance between two circuits, called the *mutual inductance*.

Definition of Inductance: The inductance, L , of a circuit is the ratio of the magnetic flux, ϕ_m , through the circuit to the current, I , flowing in the circuit,

$$\phi_m = LI.$$

Units of Inductance: The units of inductance are the Henry (H),

$$1\text{H} = 1\frac{\text{Wb}}{\text{A}} = 1\frac{\text{Tm}^2}{\text{A}}.$$

The only case where we will actually compute the inductance from scratch is the case of an infinite solenoid. The strategy is very similar to that of computing a capacitance. We take a system of conductors (usually wires) that have no current running through them and apply an arbitrary current I . We compute the flux resulting from I , then apply the definition of inductance, and cancel the arbitrary current.

Example 32.1 Compute the Inductance from the Magnetic Properties

Problem: A long inductor is made of 10000 turns of wire wound on a straw 1mm in diameter and 15cm long. Compute the inductance.

Solution

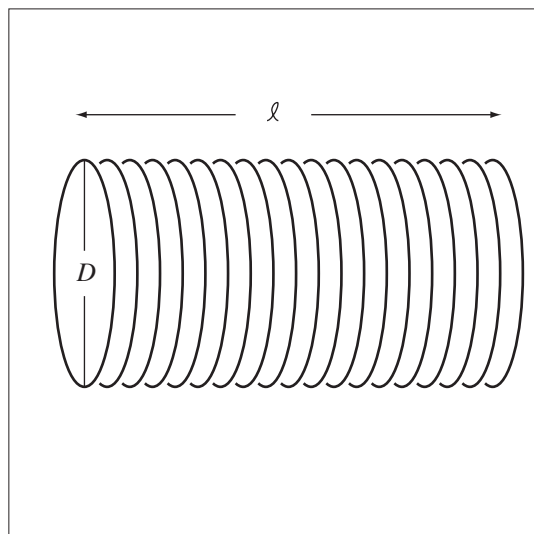

Definitions

- $N = 10000 \text{ turns} \equiv$ Number of turns of wire
 $D = 1 \text{ mm} \equiv$ Diameter of the solenoid
 $\ell = 15 \text{ cm} \equiv$ Length of the solenoid
 $L \equiv$ Inductance of the solenoid
 $R \equiv$ Radius of the solenoid
 $A \equiv$ Cross-sectional area of the solenoid
 $I \equiv$ Current
 $\phi_m \equiv$ Flux

Strategy: Introduce a current and compute the magnetic field. Compute the flux and apply definition of inductance.

(a) Introduce a Current I : Allow a current I to flow in the coil.

(b) Compute the Magnetic Field: The magnetic field in the solenoid in the infinite solenoid approximation is,

$$B = n\mu_0 I,$$

where n is the turns per unit length.

(c) Compute the Flux: The magnetic field of the solenoid creates a flux through all $N = n\ell$ turns of the solenoid. Since the field inside an infinite solenoid is uniform, the flux is

$$\phi_m = NBA = (n\ell)(n\mu_0 I)(A) = \mu_0 n^2 \ell I A$$

(d) Use Definition of Inductance: By definition,

$$L = \frac{\phi_m}{I} = \mu_0 n^2 A \ell.$$

(e) Substitute and Compute: The number of turns per length, n , is $n = N/\ell$. The cross-sectional area of the solenoid $A = \pi R^2 = \pi D^2/4$.

$$\begin{aligned}
 L &= \mu_0 \frac{N^2}{\ell^2} \frac{\pi D^2}{4} \ell \\
 L &= \frac{\mu_0 N^2 \pi D^2}{4\ell} \\
 L &= \frac{(4\pi \times 10^{-7} \frac{\text{N}}{\text{A}^2})(10000)^2 (\pi)(1 \times 10^{-3} \text{ m})^2}{4(15 \times 10^{-2} \text{ m})}
 \end{aligned}$$

$$L = 0.66 \text{ mH}$$

Inductance of a Solenoid : The inductance of a solenoid that is very long compared to its radius is

$$L = \mu_0 n^2 A \ell,$$

where $n = N/\ell$ is the turns per unit length of the solenoid, A is the area of the inductor, and ℓ is the length of the solenoid.

32.2 Inductors

Inductors are circuit elements that resist a change in current. If we substitute the definition of inductance into Faraday's Law we get the following expression for the potential difference across an inductor.

Faraday's Law for Inductor : The *emf* across an inductor with inductance, L , carrying current, I , is

$$emf = -L \frac{dI}{dt},$$

where t is the time. An inductor in a circuit carrying a constant current has zero potential difference. This *emf* will behave just like a potential difference in an electric circuit.

Symbol For Inductor: An inductor is represented in an electric circuit by the symbol to the right.

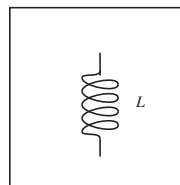

Example 32.2 Application of the Definition of Inductance

Problem: An inductor, with inductance 1H , carries a current that varies with time. The time dependence of the current is

$$I(t) = \frac{\gamma}{t^2}$$

where t is the time and $\gamma = 0.1\text{A} \cdot \text{s}^2$. Compute the potential difference across the inductor.

Solution

The potential difference across an inductor is given by $\Delta V = -L \frac{dI}{dt}$. Substituting the current

$$\Delta V = -L \frac{d}{dt} \left(\frac{0.1\text{As}^2}{t^2} \right) = \frac{(0.2\text{s}^3)}{t^3} \text{V}$$

Inductors Resist Changes in Current: An inductor produces an *emf* that tries to counter a change in current, therefore inductors have the effect of smoothing out rapidly changing currents.

To create the magnetic field in the inductor, we have to do work against the *emf* across the inductor; therefore, the inductor contains energy. The work required to set up the magnetic field is the work required to set up the current against the *emf* resisting the change in current. If the current is established over a period from 0 to T , then the work done is

$$W = - \int_0^T I \Delta V dt = - \int_0^T I \left(-L \frac{dI}{dt} \right) dt = \int_0^I LI dI = \frac{1}{2} LI^2$$

Energy Stored in Inductor : The amount of energy stored in a system of conductors with inductance L and current I is

$$U_m = \frac{1}{2} LI^2.$$

Example 32.3 Compute Potential Difference Across an Inductor

Problem: An increasing current $I(t) = \gamma t^3$ flows through an inductor with inductance L .

- (a) Compute the magnitude of the potential difference across the inductor.
 (b) Compute the energy stored in the inductor as a function of time.

Definitions

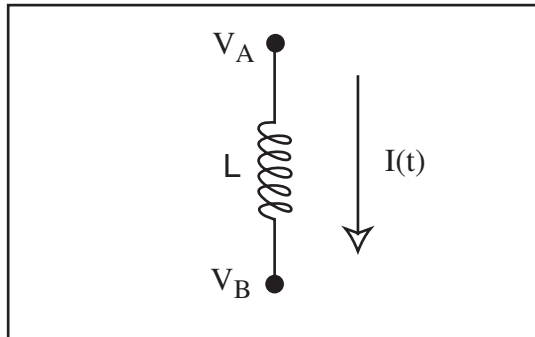

$L \equiv$ Inductance

$t \equiv$ time

$I(t) = \gamma t^3 \equiv$ Current As Drawn

$U_m \equiv$ Energy Stored in Inductor

Solution to Part (a)

The potential difference across an inductor is given by Faraday's law,

$$\Delta V = -L \frac{dI(t)}{dt} = -L \frac{d\gamma t^3}{dt} = -3\gamma L t^2.$$

Solution to Part (b)

The energy, U_m , stored in an inductor is related to the current by

$$U_m = \frac{1}{2} L I^2 = \frac{1}{2} L (\gamma t^3)^2 = \frac{1}{2} L \gamma^2 t^6$$

Example 32.4 Qualitative Inductor Problem

Problem: The figure to the right shows the current applied across an inductor as a function of time. Sketch the voltage that would be measured across the inductor.

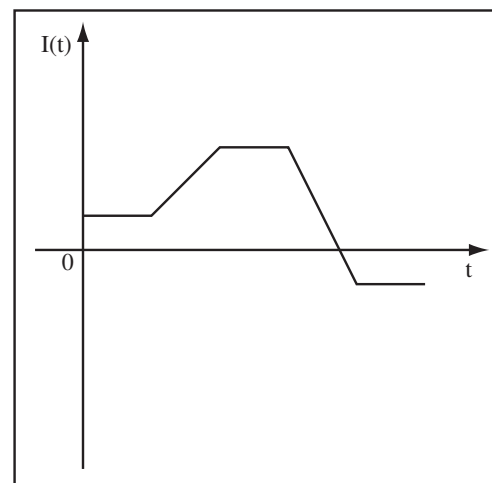

Solution

The relation between current and voltage for an inductor is $V(t) = -LdI(t)/dt$. Therefore, when the current is constant the voltage is zero. A positive slope on the current generates a negative voltage. A larger negative current generates a larger positive voltage.

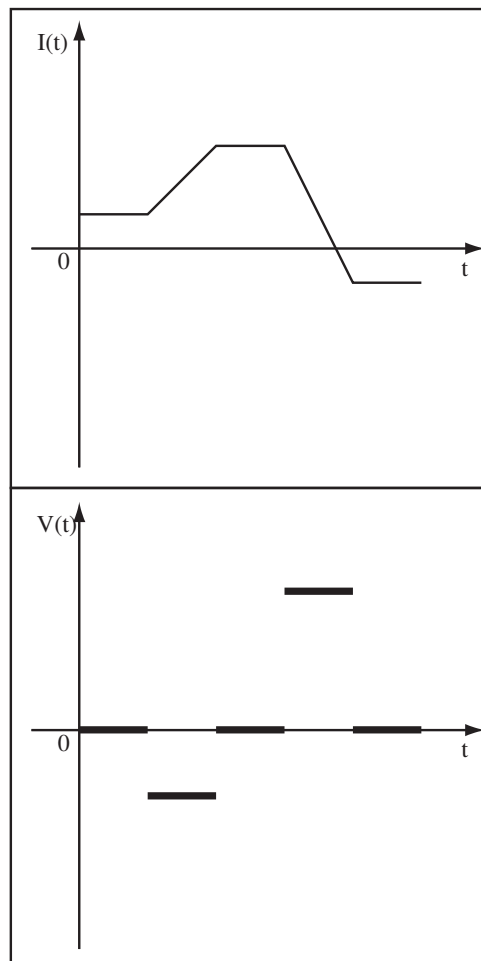

Example 32.5 Inductance and Energy of a Solenoid

Problem: A solenoid is wound with 100 turns of wire on a core with radius 2cm and length 20cm. The solenoid carries a current of 0.1A.

- What is the inductance of the solenoid assuming it is infinitely long?
- What is the magnetic field at the center of the solenoid?
- What is the magnetic flux linking the solenoid?
- What is the magnetic energy stored in the solenoid, using the ideal solenoid approximation?
- If the current in the solenoid is $I(t) = 10t^2 \text{A/s}^2$, what is the voltage across the solenoid?

Solution to Part(a)

We compute the flux in the solenoid in part (c), use that and the definition of inductance as

$$L = \frac{\phi}{I} = \frac{7.9 \times 10^{-6} \text{Tm}^2}{0.1\text{A}} = 7.9 \times 10^{-5} \text{H}$$

Solution to Part(b)

The magnetic field of an infinite solenoid is $B = n\mu_0 I$, where $n = 100/20\text{cm} = 500\text{m}^{-1}$ is the turns per unit length and $I = 0.1\text{A}$. Substituting gives

$$B = n\mu_0 I = (500\text{m}^{-1})(4\pi \times 10^{-7} \frac{\text{Tm}}{\text{A}})(0.1\text{A}) = 6.3 \times 10^{-5}\text{T}$$

Solution to Part(c)

The magnetic flux linking the solenoid is $\phi_m = NAB$ where A is the area and $N = 100$ is the number of turns. The area of the solenoid is $A = \pi r^2$. Substituting gives

$$\phi_m = NAB = (100)\pi(2\text{cm})^2(6.3 \times 10^{-5}\text{T}) = 7.9 \times 10^{-6}\text{Tm}^2$$

Solution to Part(d)

The magnetic energy is

$$U_m = \frac{1}{2}LI^2 = \frac{1}{2}(7.9 \times 10^{-5}\text{H})(0.1\text{A})^2 = 3.95 \times 10^{-7}\text{J}$$

Solution to Part(e)

Faraday's Law states the induced emf in a circuit is

$$emf = -\frac{d\phi_m}{dt} = -L\frac{dI(t)}{dt}$$

$$emf = -L\left(10\text{A/s}^2\right)\frac{dt^2}{dt} = -L\left(20\text{A/s}^2\right)t = -(7.9 \times 10^{-5}\text{H})(20\text{A/s}^2)t = -(1.6 \times 10^{-3}\text{V/s})t$$

32.3 Mutual Inductance and Transformers

The self-inductance is a property of a single circuit. The flux produced by one circuit can also generate an *emf* in a circuit that is otherwise electrically isolated.

Definition of Mutual Inductance: Given two circuits, A and B, the mutual inductance M_{AB} is the ratio of the flux, ϕ_A , through circuit A caused by the current in circuit B, I_B ,

$$\phi_A = M_{AB}I_B.$$

The mutual inductance is symmetric $M_{AB} = M_{BA}$.

Mutual inductance is the physical origin of the behavior of a transformer in an electrical circuit. A transformer is usually two isolated coils of wire wound on the same iron core so that the flux of one coil links the other coil. Transformers can provide electrical isolation because the two circuits are not connected by a conducting path, only by magnetic fields. If the two loops have different numbers of turns, the transformer can be used to increase (step up) or decrease (step down) the voltage of a signal. This is the purpose of the transformers you see on power lines. It is more efficient to transport electricity at high voltages. These voltages must be decreased (stepped down) for household use.

Transformer Circuit Symbol:

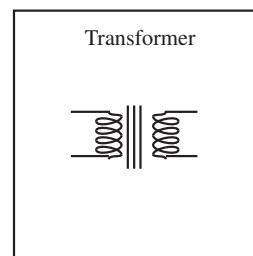

Suppose we wind two separate coils of wire, a and b , on a ferromagnetic ring. The ferromagnet will ensure that the flux created when a voltage ΔV_a is applied across coil a is delivered to coil b . If ϕ_1 is the magnetic flux created by one turn of wire, then the total flux is approximately $\phi_m = N_a \phi_1$, where N_a is the number of turns of wire on coil a . By Faraday's law, the *emf* across coil a is

$$\Delta V_a = -N_a \frac{d\phi_1}{dt}$$

If all the flux is delivered to coil b , the *emf* induced in coil b is

$$\Delta V_b = -N_b \frac{d\phi_1}{dt}$$

where N_b is the number of turns on coil b . Combining these two expressions gives,

$$\frac{\Delta V_a}{N_a} = \frac{\Delta V_b}{N_b}$$

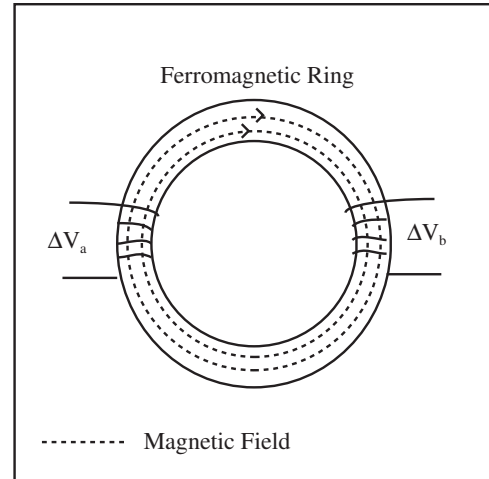

Transformer Output Voltage: If a transformer is formed from two coils where the first coil is wound with N_a turns and the second coil is wound with N_b turns then the ratio of the input voltage ΔV_a to the output voltage is ΔV_b is

$$\frac{\Delta V_b}{\Delta V_a} = \frac{N_b}{N_a}$$

Example 32.6 Mutual and Self-Inductance

Problem: A loop of wire carries 5A of current, which generates a total magnetic flux of 0.0001Tm^2 through the loop.

- Compute the self-inductance of the loop.
- Compute the magnetic energy stored in the system.
- If another loop of the same shape is laid over the first loop, so that the same flux links the second loop, compute the mutual inductance of the system.

Solution to Part(a)

The self-inductance, L , is defined as $L = \phi_m/I$, therefore

$$L = \frac{\phi_m}{I} = \frac{1 \times 10^{-4}\text{Tm}^2}{5\text{A}} = 2 \times 10^{-5}\text{H}$$

Solution to Part(b)

The magnetic energy stored in an inductor is given by

$$U_m = \frac{1}{2}LI^2 = \frac{1}{2}(2 \times 10^{-5}\text{H})(5\text{A})^2 = 2.5 \times 10^{-4}\text{J}$$

Solution to Part(c)

Since the loop and the flux are the same $M_{12} = \phi_{m,2}/I_1 = 2 \times 10^{-5}\text{H}$

Example 32.7 Compute Mutual Inductance from the Magnetic Properties

Problem: Two flat loops of wire, A and B , lie in the $x-y$ plane. Loop A is centered at the origin and carries a current $I_A = 20\text{A}$, which produces a flux $\phi_B = 100\text{Wb}$ in coil B . Loop B carries a current $I_B = 10\text{A}$, which creates a flux of 50Wb in loop A . Compute the mutual inductance.

Solution

(a) Use Definition of Mutual Inductance for M_{BA} :

$$M_{BA} = \phi_B/I_A = 100\text{Wb}/20\text{A} = 5\text{H}$$

(b) Use Definition of Mutual Inductance for M_{AB} :

$$M_{AB} = \phi_A/I_B = 50\text{Wb}/10\text{A} = 5\text{H}$$

It is always true that $M_{AB} = M_{BA}$.

Example 32.8 Problems in Inductance

Problem: A solenoid has length 25cm , radius 1cm and 400 turns. It carries a current of I .

- (a) Compute the magnetic field of the solenoid.
- (b) Find the flux through the solenoid, assuming B to be uniform.
- (c) Compute the self-inductance of the solenoid.
- (d) Compute the mutual inductance, $M_{\text{solenoid,loop}}$, of the solenoid and a single loop of wire with radius 2cm co-axial with the solenoid.

Strategy: Apply formula for magnetic field of solenoid, then definition of self and mutual inductance.

Solution to Part(a)

The magnetic field of a solenoid is $B = n\mu_0 I$ where n is the turns per unit length and I is the current. The turns per unit length is the number of turns, N , divided by the length, ℓ , $n = N/\ell = 400/0.25\text{m} = 1600\text{m}^{-1}$. So

$$B = n\mu_0 I = (1600\text{m}^{-1})\mu_0 I$$

Solution to Part(b)

To compute the inductance, we need to compute the magnetic flux in terms of an arbitrary current. Using the field computed above, $\phi_m = NAB$ where $A = \pi r^2$ is the area of the solenoid, with r the radius of the solenoid. Substituting everything gives

$$\phi_m = N(\pi r^2)(n\mu_0 I) = (n\ell)(\pi r^2)(n\mu_0 I) = \pi n^2 r^2 \mu_0 \ell I.$$

Solution to Part(c)

The self-inductance, L , is defined as

$$L = \frac{\phi_m}{I} = \pi n^2 r^2 \mu_0 \ell$$

$$L = (1600\text{m}^{-1})^2 \pi (1\text{cm})^2 (4\pi \times 10^{-7} \frac{\text{Tm}}{\text{A}}) (0.25\text{m}) = 2.5 \times 10^{-4} \text{H}$$

Solution to Part(d)

The mutual inductance, $M_{solenoid,loop}$, from the flux through the single loop generated by the field of the solenoid is defined as

$$M_{solenoid,loop} = \phi_{loop} / I_{solenoid}$$

where ϕ_{loop} is the magnetic flux through the loop and $I_{solenoid}$ is current through the solenoid. The magnetic flux through the loop is $\phi_{loop} = A_{solenoid}B = \pi r_{solenoid}^2 B$ since there is only one turn of wire and the magnetic field only exists inside the solenoid. Substituting the expression for the magnetic field of the solenoid gives

$$\phi_{loop} = \pi r_{solenoid}^2 n \mu_0 I_{solenoid}$$

giving a mutual inductance of

$$M_{solenoid,loop} = \frac{\phi_{loop}}{I_{solenoid}} = \pi r_{solenoid}^2 n \mu_0 = \pi (1\text{cm})^2 (1600\text{m}^{-1}) (4\pi \times 10^{-7} \frac{\text{Tm}}{\text{A}}) = 6.3 \times 10^{-7} \text{H}$$

Chapter 33

Magnetic Energy

33.1 Magnetic Energy

We can compute the energy stored in the magnetic field in a number of ways, from the energy density, from the inductance, or from the work to establish the field. The electric field contained energy which could be expressed as an energy density. The field contained energy because it required work to move electric charge into the configuration that generated the field. Magnetic fields contain energy, which can be expressed as an energy density. The magnetic field has energy because of the work required to establish the currents that create the field.

Consider a circular solenoid of length ℓ and end area A . The volume of the solenoid is $V = \ell A$ and the inductance in the infinite solenoid approximation is $L = \mu_0 n^2 A \ell$. The energy of the solenoid is $U = \frac{1}{2} L I^2$ and the energy density, η_m , is

$$\eta_m = \frac{U}{V} = \frac{\frac{1}{2} L I^2}{V} = \frac{\frac{1}{2} (\mu_0 n^2 A \ell) I^2}{\ell A} = \frac{1}{2} \mu_0 n^2 I^2$$

The magnetic field in the solenoid is $B = \mu_0 n I$. If the energy density is expressed in terms of the field we get

$$\eta_m = \frac{B^2}{2\mu_0}$$

This must be the energy density of any magnetic field.

Energy Density of Magnetic Field : The energy density of the magnetic field, η_m , is

$$\eta_m = \frac{B^2}{2\mu_0},$$

where B is the magnitude of the magnetic field.

Example 33.1 Energy Stored in Solenoid

Problem: The magnetic field in a small region inside a solenoid is 4.0mT.

- (a) What is the magnetic energy density in this region?
- (b) What is the total energy stored in a cube 1cm on a side in this region in the solenoid?

Solution to Part (a)

The energy density

$$\eta_m = \frac{B^2}{2\mu_0} = \frac{(4 \times 10^{-3} \text{T})^2}{2(4\pi \times 10^{-7} \frac{\text{Tm}}{\text{A}})} = 6.37 \frac{\text{J}}{\text{m}^3}$$

Solution to Part (b)

The total energy, U_m , in a 1cm cubic volume, V , is density multiplied by the volume

$$U_m = \eta_m V = (6.37 \frac{\text{J}}{\text{m}^3})(0.01\text{m})^3 = 6.37 \times 10^{-6} \text{ J}$$

Chapter 34

RL Circuits

34.1 Limiting Behavior of RL Circuits

Faraday's Law states that an inductor will set up an *emf* that resists the change in magnetic flux through the inductor. For self-inductance, the magnetic flux is generated by the current flowing through the inductor. Therefore, an inductor will set up an *emf* to resist a change in current through itself. We can consider connecting an inductor in series with a resistor and maybe a battery, just as we did in RC circuits. We will call such a connection an *RL circuit*. Consider the same cases used in RC circuits:

- **RL Charging:** An inductor with zero initial current is connected in series with a battery and a resistor. After a long time the current will be constant and (by Faraday's Law) the voltage across the inductor will be zero.
- **RL Discharging:** An inductor carrying some current is connected to a resistor. The current through the inductor will gradually decay as the energy stored in the inductor is dissipated in the resistor.

The charging and discharging terminology is in analogy to the RC circuit. An inductor is "charged" when a current flows through it. The key to analyzing these circuits is to understand what Faraday's law implies about the behavior of the devices. Because of Faraday's Law, an inductor will not allow a sudden change in the current in a circuit. Therefore, when an inductor with zero current flowing through it is connected to a battery through a resistor, the current cannot immediately change to a non-zero value. In this case, immediately after connection to the battery, the current through the circuit is zero, and therefore, by Ohm's Law, the voltage across the resistor is zero. Therefore, to analyze the initial voltages in an RL circuit:

Short-Time Charging Behavior: At short times after connection to the battery, the current is zero (or approximately zero), which means the potential difference across the resistors is zero. Although the current is zero, the *change in current* is non-zero, which means there is a potential difference across an inductor.

Reducing a Resistor in a Circuit with Zero Current : If no current is flowing in a circuit, then there is no potential difference across a resistor and it can be replaced by a wire. This means that the *emf* across the inductor will be the same size as the applied potential difference, and in the opposing direction.

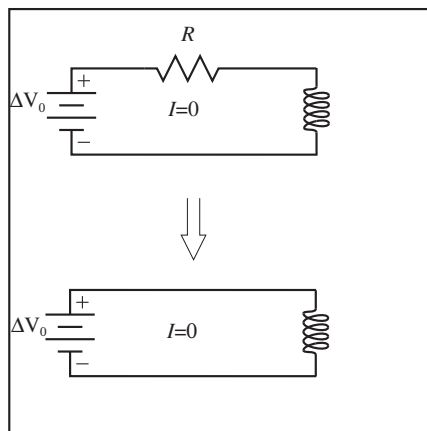

After an inductor has been connected to a battery for a long time, the current reaches a constant final value. If the current through an inductor is unchanging, then the potential difference across the inductor is zero.

Long-Time Charging Behavior: At long times the current in the circuit has reached a steady value (no change), which means that there is no electric potential difference across the inductor. This allows the inductor to be replaced by a straight wire.

We can use these observations to analyze the long and short time behavior of RL circuits.

Example 34.1 Analyze Short Time Behavior of an RL Circuit

Problem: An RL circuit is formed from two resistors, an inductor, and a battery in series. The circuit elements have the following values: $V = 12\text{V}$, $R_1 = 3.0\text{M}\Omega$, $R_2 = 6.0\text{M}\Omega$, and $L = 3.0\mu\text{H}$. When answering the following questions, assume that the circuit has *just* been closed (analysis in the short-time limit). What is the current through each resistor? What is the potential difference across each resistor? What is the potential difference across the inductor?

Solution

Definitions

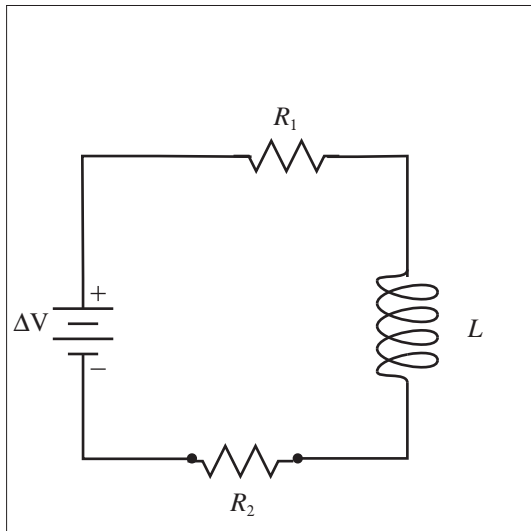

$\Delta V = 12\text{V} \equiv$ Potential difference between battery terminals

$R_1 = 3.0\text{M}\Omega \equiv$ Resistance of first resistor

$R_2 = 6.0\text{M}\Omega \equiv$ Resistance of second resistor

$L = 3.0\mu\text{H} \equiv$ Inductance of inductor

$I \equiv$ Current through the circuit

$\Delta V_1 \equiv$ Potential difference across first resistor

$\Delta V_2 \equiv$ Potential difference across second resistor

$\Delta V_L \equiv$ Potential difference across inductor

Strategy: Use the fact that at short periods of time, the resistors can be replaced by straight wires. Analyze the resulting DC circuit.

(a) Redraw Circuit: Redraw the circuit replacing the resistors with wires. The current through the circuit is approximately zero,

$$I \approx 0\text{A}$$

Using Ohm's Law shows that the potential difference across the resistors is approximately zero.

$$\Delta V_1 \approx 0\text{V} \quad \Delta V_2 \approx 0\text{V}$$

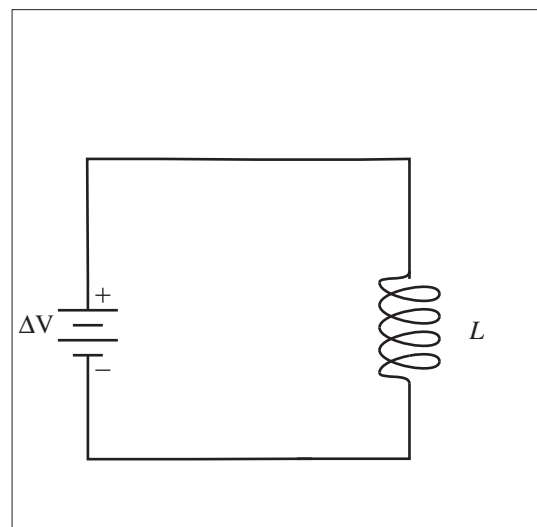

(b) Solve the DC Circuit: The resulting circuit is a simple DC circuit and the potential differences can be solved for using techniques for DC circuits. Since the terminals of the battery are connected directly to the terminals of the inductor, the potential difference across each is the same,

$$\Delta V_L = \Delta V = 12V$$

Example 34.2 Analyze Long Time Behavior of an RL Circuit

Problem: An RL circuit is formed from two resistors, an inductor, and a battery in series. The circuit elements have the following values: $V = 12V$, $R_1 = 3.0M\Omega$, $R_2 = 6.0M\Omega$, and $L = 3.0\mu H$. When answering the following questions, assume that the circuit has been closed for a long time. What is the current through each resistor? What is the potential difference across each resistor? What is the current through the inductor and the potential difference across it?

Solution

Definitions

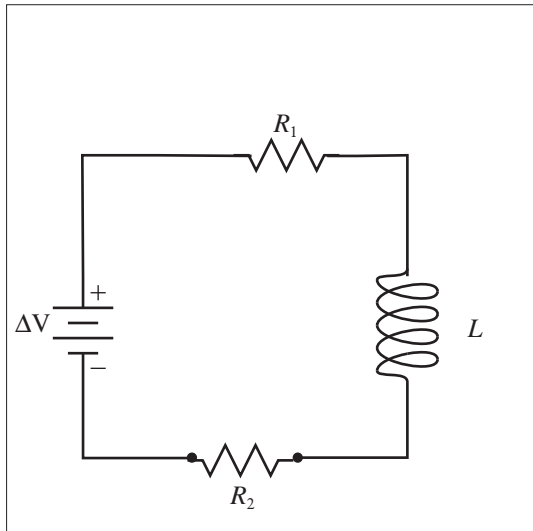

$\Delta V = 12V \equiv$ Potential difference between battery terminals

$R_1 = 3.0M\Omega \equiv$ Resistance of first resistor

$R_2 = 6.0M\Omega \equiv$ Resistance of second resistor

$L = 3.0\mu H \equiv$ Inductance of inductor

$I \equiv$ Current through the circuit

$\Delta V_1 \equiv$ Potential difference across first resistor

$\Delta V_2 \equiv$ Potential difference across second resistor

$\Delta V_L \equiv$ Potential difference across inductor

Strategy: Use the fact that at long periods of time, the inductor passes the current unimpeded. Analyze the resulting DC Circuit.

(a) Redraw Circuit: Redraw the circuit by replacing the inductor with a straight wire. The circuit given in the problem is simplified in the long-time limit to be without the inductor, leaving the two resistors in series with the battery.

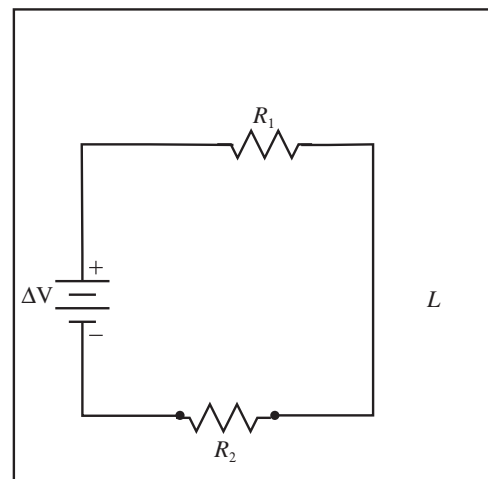

(b) Solve the DC Circuit: The resulting circuit is a simple DC circuit and the currents can be solved for using techniques for DC circuits. The two resistors in series can be reduced to a single equivalent resistor, $R_s = 9.0\text{M}\Omega$. The potential drop across this resistor is the same as that between the terminals of the battery. Using Ohm's Law, we find the current through the equivalent resistor

$$I = \Delta V / R_s = 12\text{V} / (9.0 \times 10^6 \Omega) = \frac{4}{3} \mu\text{A}$$

which is the current through both real resistors since they are in series.

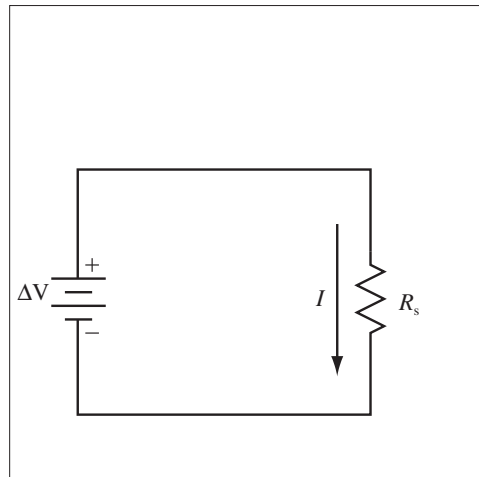

(c) Find the Potential Difference: Use Ohm's Law to find the potential differences. We can use Ohm's Law, $\Delta V = IR$, to find the potential difference across each resistor.

$$\Delta V_1 = IR_1 = \left(\frac{4}{3} \times 10^{-6} \text{A} \right) \cdot (3.0 \times 10^6 \Omega)$$

$$\Delta V_1 = 4.0\text{V}$$

$$\Delta V_2 = IR_2 = \left(\frac{4}{3} \times 10^{-6} \text{A} \right) \cdot (6.0 \times 10^6 \Omega)$$

$$\Delta V_2 = 8.0\text{V}$$

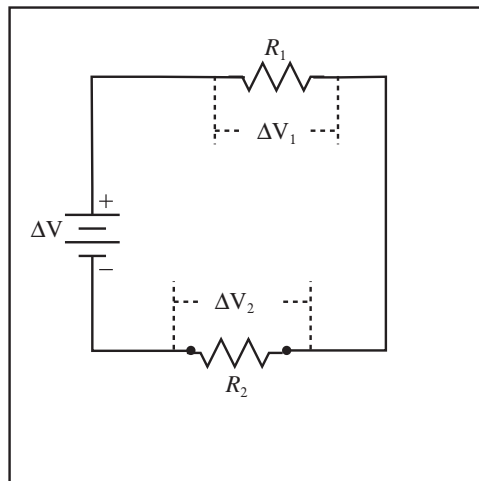

(d) Compute Voltage Drop Across Inductor: Since the current does not *change* in the long-time limit, the potential difference across the inductor is zero.

$$\Delta V_L = 0$$

Since the inductor is in series with the resistors, the current through it is the same as through them.

$$I = \frac{4}{3} \times 10^{-3} \text{A}$$

34.2 RL Circuits

This section covers computing the functional form of the current and voltage in an RL circuit. The time dependence of current through the circuit and the potential differences across the inductor and resistor are the same increasing or decreasing exponential curves we encountered in RC circuits. The time dependence is characterized by a time constant τ . For an RL circuit,

Time Constant, τ : The time constant of an RL circuit is $\tau = L/R$, where R is the total resistance and L is the inductance.

Since all the time dependence curves are exponentials involving the time constant, the key step in an RL circuit problem is to determine whether the time dependence of the quantity of interest is an increasing or decreasing exponential.

Increasing Exponential Curve: Some features of RL circuits increase with time, they have a general time dependence of

$$1 - \exp(-t/\tau),$$

which at time $t = 0$ is zero and increases to 1 at long periods of time. The graph to the right might be the potential difference across a resistor in a “charging” RL circuit with a battery with voltage $\Delta V_b = 10V$, and time constant $\tau = 10s$.

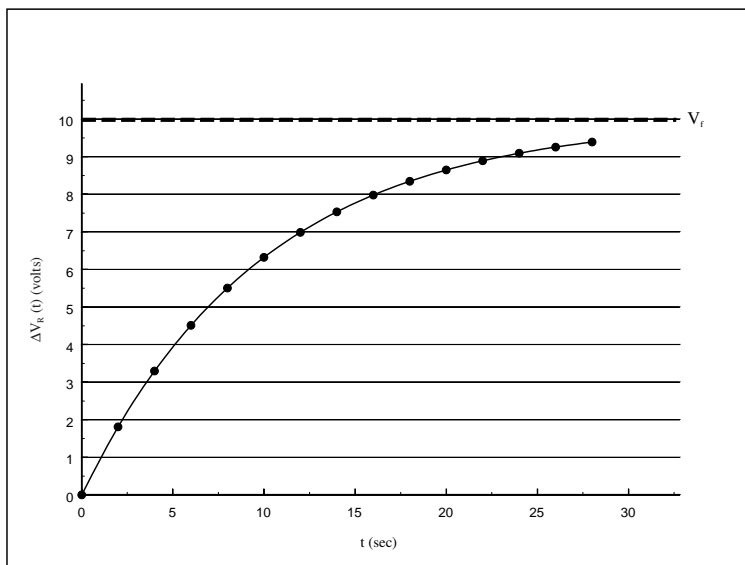

Decreasing Exponential Curve: Some features of RL circuits decrease with time, they have a general time dependence of

$$\exp(-t/\tau),$$

which at time $t = 0$ is one and decreases to 0 at long periods of time. The graph to the right might be the potential difference across a “discharging” inductor with initial potential difference $\Delta V_0 = 10\text{V}$, and time constant $\tau = 10\text{s}$.

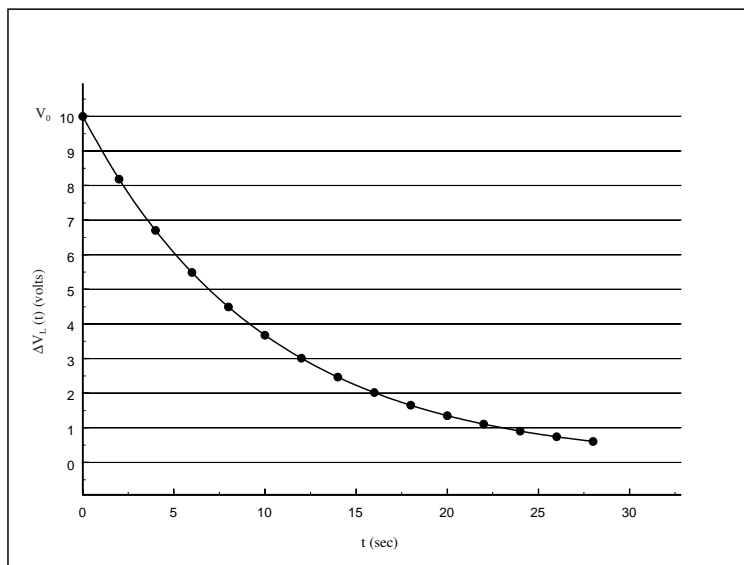

We can apply these mathematical forms to charging and discharging RL circuits.

Time Dependence in a “Charging” RL Circuit: If an initially “uncharged” inductor with inductance L is charged by a battery with potential difference ΔV_0 through a resistor with resistance R , then the time dependence of the current through the inductor is

$$I_L(t) = I_f [1 - \exp(-t/\tau)]$$

where I_f is the final, steady current after the inductor has fully “charged.” The potential difference across the inductor, $\Delta V_L = -L \frac{dI(t)}{dt}$, is

$$\Delta V_L(t) = V_0 \exp(-t/\tau).$$

Example 34.3 Analyze Charging Behavior of an RL Circuit

Problem: A 3.0mH inductor is in series with a 9.0Ω resistor. These are then connected across a 6.0V battery and the inductor is allowed to “charge”. What is the time-dependent current through the resistor?

Solution

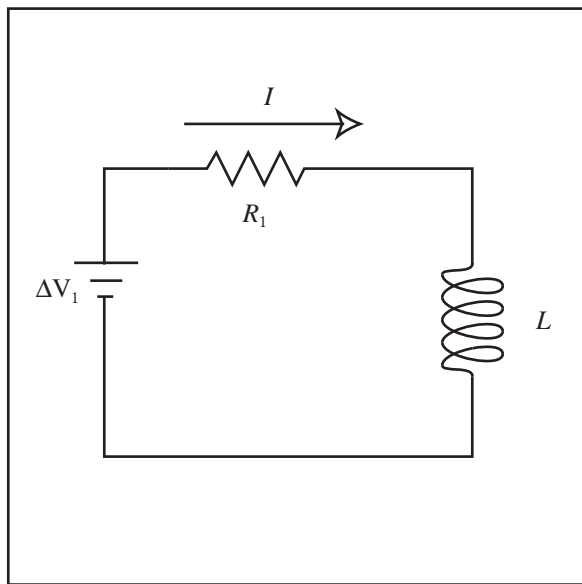

Definitions

- $R_1 = 9.0\Omega \equiv$ Resistance of Resistor 1
 $\Delta V_1 = 6.0V \equiv$ Potential Difference Across Battery
 $L = 3.0mH \equiv$ Inductance of the inductor
 $I(t) \equiv$ Current in the circuit
 $I_f \equiv$ Final current through the resistor

Strategy: Use formula for charging inductor, and fix the constant from the long-time behavior.

(a) Compute Final Current, I_f , Through the Circuit: Use Example 34.2 Analyze Long Time Behavior of an RL Circuit, to get I_f , which for the circuit in the figure is simply $I_f = \Delta V_1/R_1$.

$$I_f = \Delta V_1/R_1 = 6.0V/9.0\Omega = (2/3)A$$

(b) Compute Time Constant, τ : The time constant of an RL circuit is $\tau = L/R$,

$$\tau = L/R_1 = 3.0 \times 10^{-3}H/9.0\Omega = 0.33ms$$

(c) Use “Charging” Form of Current: The current in a charging RL circuit is

$$I(t) = I_f [1 - \exp(-t/\tau)]$$

The current has its minimum value at $t = 0$, and then increases to its final value, so the proper form of the time dependence is

$$I(t) = I_f [1 - \exp(-t/\tau)]$$

$$I(t) = 2/3A \{1 - \exp[-t/0.33 \times 10^{-3}s]\}$$

Time Dependence in a “Discharging” RL Circuit: If an inductor with inductance L , and initial current I_0 , “discharges” through a resistor with resistance R , then the time dependence of the current through the inductor is

$$I_L(t) = I_0 \exp(-t/\tau)$$

When two objects are alone in series, their potential drops must be equal and opposite and the current flowing through them must be the same. The potential difference across the resistor is always IR . The potential difference across the inductor is also $I_L(t)R$ or

$$\Delta V_L(t) = \Delta V_0 \exp(-t/\tau)$$

where $\Delta V_0 = I_0R$. You also get this result from directly applying $\Delta V_L(t) = -L \frac{dI(t)}{dt}$.

Example 34.4 Analyze Discharging Behavior of an RL Circuit

Problem: A 3.0mH inductor initially has a current of 4.0A through it. This inductor is then placed in series with a 9.0Ω resistor and allowed to “discharge”. What is the time-dependent current through the resistor?

Solution

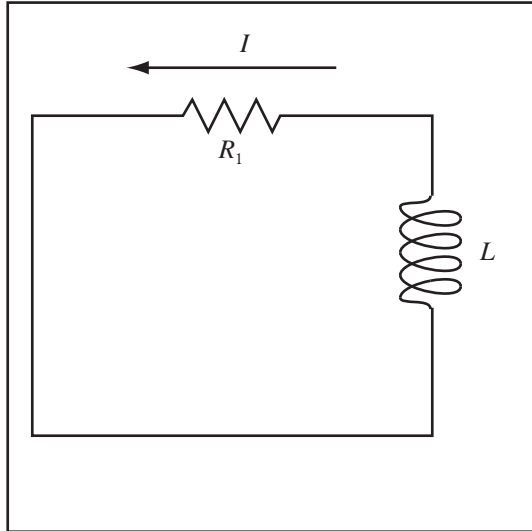
Definitions

$R_1 = 9.0\Omega \equiv$ Resistance of Resistor 1
 $L = 3.0\text{mH} \equiv$ Inductance of the inductor
 $I(t) \equiv$ Current in the circuit
 $I_0 = 4.0\text{A} \equiv$ Initial Current

Strategy: Use formula for discharging inductor in an RL circuit.

(a) Compute Time Constant, τ : The time constant of the circuit is

$$\tau = L/R.$$

The time constant of an RL circuit is $\tau = L/R$,

$$\tau = L/R_1 = 3.0 \times 10^{-3}\text{H}/9.0\Omega = 0.33\text{ms}$$

(b) Use Discharging Form of Current: The current in a discharging RL circuit is

$$I(t) = I_0 \exp(-t/\tau).$$

Since the current in the circuit starts at its highest value I_0 and decays toward zero, the correct form of the time dependence is a decaying exponential.

$$I(t) = I_0 \exp(-t/\tau)$$

$$I(t) = 4.0\text{A} \exp[-t/0.33 \times 10^{-3}\text{s}]$$

Chapter 35

Final Topics Test 3

35.1 Devices Utilizing the Lorentz Force

35.1.1 Speaker I

The first speaker we built attached a magnet to the base of a paper cup and then wound a coil of wire around the cup.

- (1) Changing current from music source produces a changing, non-uniform field.
- (2) Changing non-uniform field produces a changing force on the magnetic dipole.
- (3) A changing force is communicated to the bottom of the cup, where vibrations on the cup from the coil produce sound.

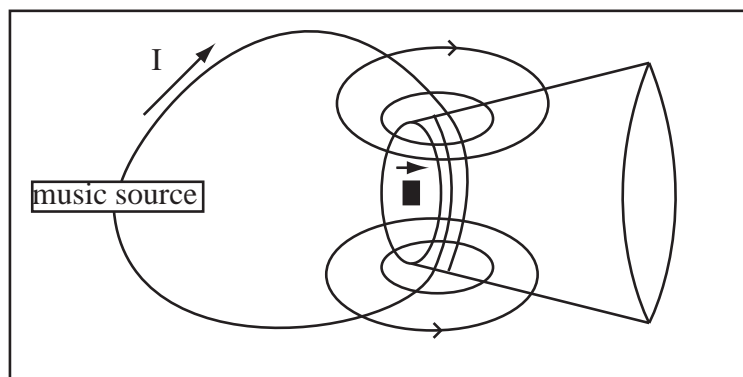

35.1.2 Speaker II (Commercial)

The second type of speaker we built attached a coil of wire to a flat board. The speaker was then placed in a magnetic field and the board vibrated to produce sound.

- (1) Permanent magnets produce a static field.
- (2) The music source produces a time-varying current which experiences a time-varying force (Lorentz force).
- (3) The net upward or downward force is communicated to the sounding board, which vibrates, causing sound.

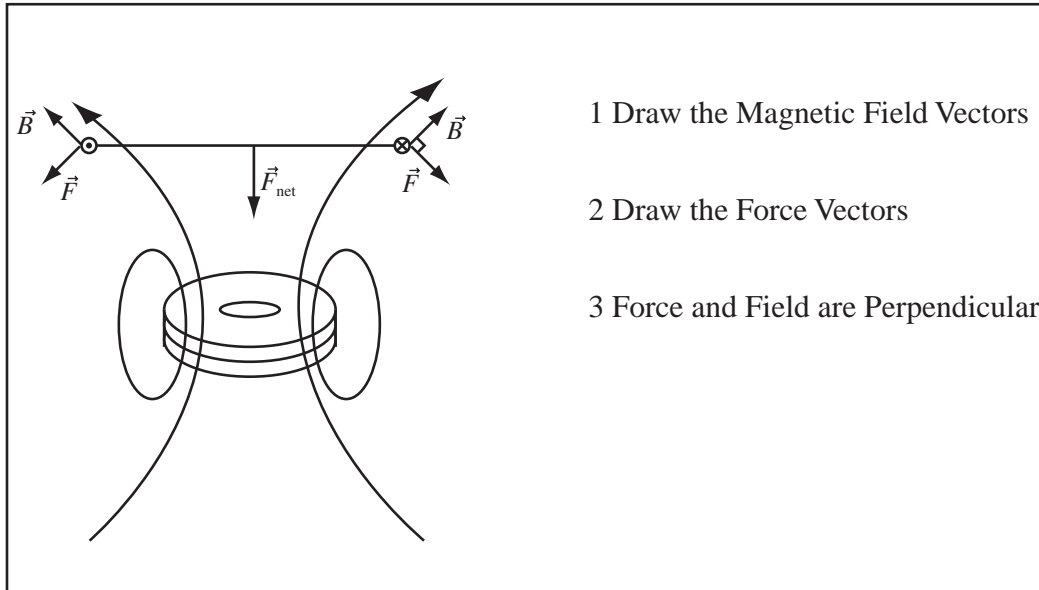

35.1.3 Motors

We also built a motor in lab. The motor was composed of a coil of wire with one end completely sanded and one end half sanded suspended by a paper clip.

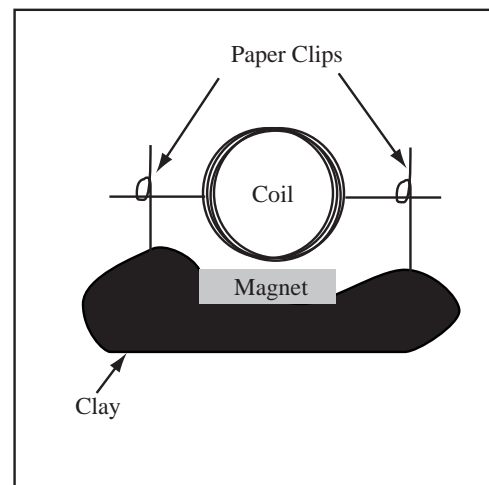

The motor turned electrical energy into mechanical energy by,

- **(1)** Magnets produce static (unchanging) magnetic fields.
- **(2)** A magnetic field exerts torque on the loop that causes it to rotate toward equilibrium. This force is called the Lorentz Force.
- **(3)** The current is turned on and off so torque only acts in one direction, causing rotation.

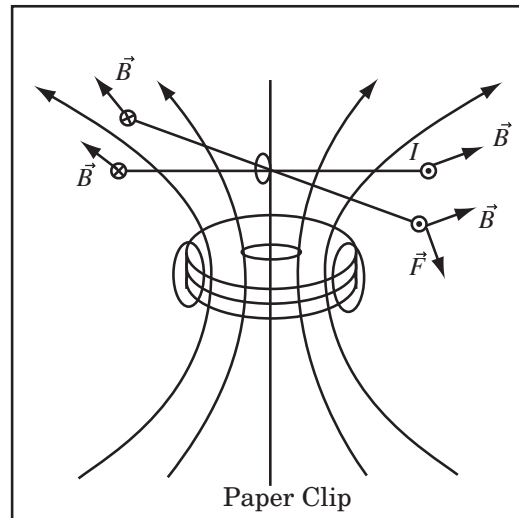

Draw the field so it extends to the coil, draw the direction of the field at both ends of the coil, then the direction of the force using the Lorentz force. Common mistakes made in the description of speakers and motors.

- (1) Magnetic fields DO NOT interact to produce force. Force is produced by the action of the field on current, or sometimes atomic current in permanent magnets.
- (2) Draw the field so that it extends to coil.
- (3) NO FARADAY in speakers– Faraday is involved in generators and microphones.

35.2 Devices Utilizing Faraday's Law

35.2.1 Microphones

A microphone turns sound vibrations into electrical signals.

- (1) The permanent magnet creates a static magnetic field.
- (2) Sound vibrations vibrate the magnet, causing a changing magnetic field at the coil and thus a changing magnetic flux.
- (3) A changing magnetic flux produces an emf by Faraday's Law.

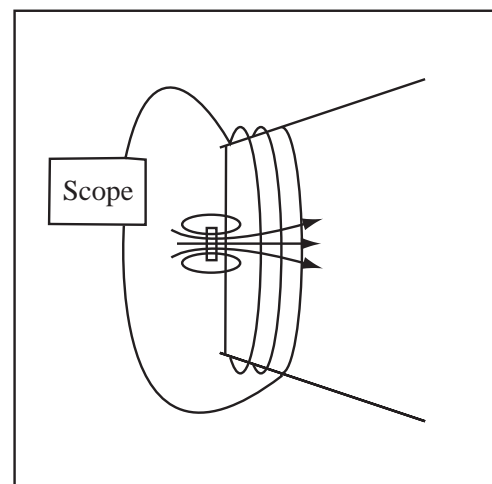

35.2.2 Generators

A generator converts mechanical energy into electrical energy.

- (1) A coil of wire is placed in a permanent magnetic field.
- (2) The coil is spun by an external force.
- (3) The flux through the surface bounded by the coil changes with time.
- (4) A changing flux produces an emf by Faraday's Law.

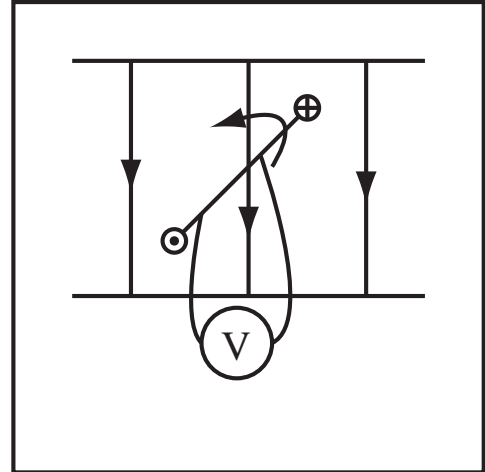

Chapter 36

Displacement Current

36.1 Displacement Current

36.1.1 Why Does Ampere's Law Need Fixing?

Faraday's Law stated that a changing magnetic field produces an electric field. We could expect a certain level of symmetry in the universe, but up to now, there has been no law about the effect of a changing electric field. The form of Ampere's law we have been using applies only when there are no changing electric fields. When there are changing electric fields, Ampere's law picks up another term.

Consider a parallel plate capacitor in the process of being charged with a current I as shown below. Let the plate area be A and the plate separation be d .

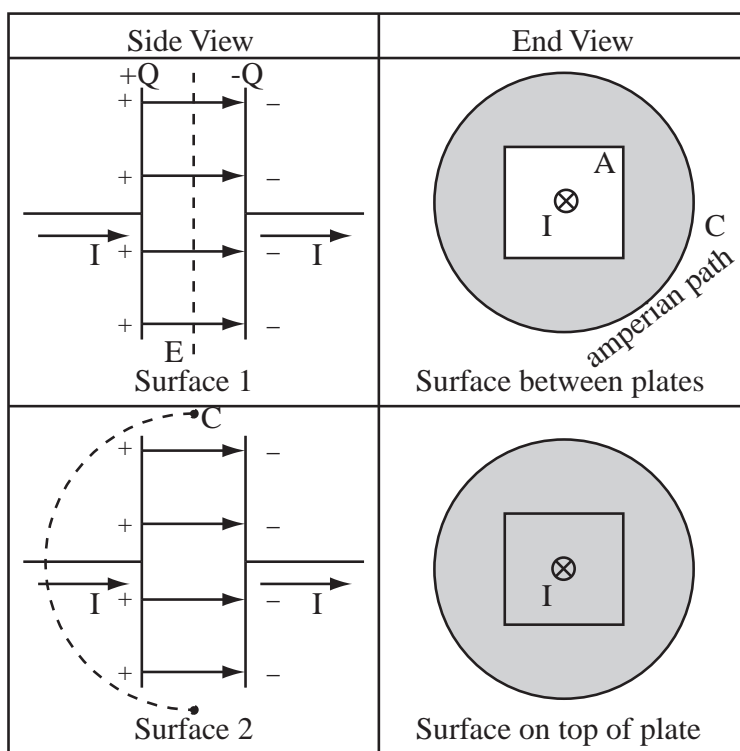

Ampere's Law applies to any surface bounding the path C . Two possible surfaces bounded by C are drawn above. Surface 1 passes between the plates and surface 2 passes outside of the plates. Since both surfaces are bounded by C , Ampere's law should give the same result for both surfaces.

Apply Ampere's law to surface 1. Since no current passes between capacitor plates the current passing through the surface is $I_{encircled} = 0$ and applying Ampere's law

$$\int_C \vec{B} \cdot d\vec{\ell} = 0$$

For surface 2, the current flowing through the surface is $I_{encircled} = I$ and applying Ampere's law gives

$$\int_C \vec{B} \cdot d\vec{\ell} = \mu_0 I \quad \text{Whoops!}$$

Since both surfaces are bounded by C , both surfaces can be used in Ampere's law and the results for both surfaces must be the same.

We are going to fix Ampere's Law by adding another term that makes the contribution from surface 1 the same as that from surface 2. This term will be called the displacement current, I_d .

$$\oint_C \vec{B} \cdot d\vec{\ell} = \mu_0(I + I_d)$$

Comparing Ampere's law with Faraday's law, we would expect this additional term to depend on a changing electric flux. The electric flux, ϕ_e , through surface 1 is,

$$\phi_e = EA = \frac{\sigma}{\epsilon_0} A$$

where I have used the electric field of equal and opposite planes as $E = \sigma/\epsilon_0$. The charge density on the positive plate is $\sigma = Q/A$ so

$$\phi_e = \frac{A}{\epsilon_0} \left(\frac{Q}{A} \right) = \frac{Q}{\epsilon_0}$$

Solving for Q gives

$$Q = \epsilon_0 \phi_e$$

The current is the derivative of the charge

$$\frac{dQ}{dt} \equiv I = \epsilon_0 \frac{d\phi_e}{dt} = I_d$$

The displacement current, I_d , is a quantity with the dimensions of current needed to complete Maxwell's equations.

$$I_d = \epsilon_0 \frac{d\phi_e}{dt} = \epsilon_0 \frac{d}{dt} \int_S (\vec{E} \cdot \hat{n}) dt$$

A changing electric flux creates a magnetic field.

36.1.2 Ampere's Law for Electrodynamics

With the addition of the displacement current we can state a form of Ampere's law that is always correct.

Definition Displacement Current : The displacement current for a surface is a mathematical quantity that has the same units as current. The displacement current, I_d , is

$$I_d = \epsilon_0 \frac{d\phi_e}{dt} = \epsilon_0 \frac{d}{dt} \int_S (\vec{E} \cdot \hat{n}) dA,$$

where ϕ_e is the electric flux through the surface, and t is time.

The displacement current is formed of the time derivative of electric flux, just as Faraday's Law uses the time derivative of magnetic flux. The current acts as an additional source of magnetic field in Ampere's Law.

Ampere's Law for Electrodynamics: For situations where there is a changing electric field, Ampere's Law must be modified as follows,

$$\oint_C \vec{B} \cdot d\vec{\ell} = \mu_0(I + I_d),$$

where \vec{B} is the magnetic field, C is a closed curve, $\vec{\ell}$ points along the curve, I is the real current (the moving charged particles) through the surface, and I_d is the displacement current for the surface enclosed by the curve.

A changing electric flux through a surface S produces a net magnetic field around the curve bounding the surface.

The Displacement Current is Not a Real Current: The displacement current has the dimensions of current but does not involve the transfer of charged particles through the surface.

Example 36.1 Displacement Current Given Flux

Problem: A cylindrical region of space supports a changing electric field along its length. The electric flux for the cross section of the region is computed to be $\phi_e = (100 \frac{Nm^2}{Cs^2})t^2$. Compute the displacement current as a function of time.

Solution

The displacement current, I_d , is defined as

$$I_d = \epsilon_0 \frac{d\phi_E}{dt} = \epsilon_0 \frac{d}{dt} (100 \frac{Nm^2}{Cs^2})t^2 = 2\epsilon_0 (100 \frac{Nm^2}{Cs^2})t$$

$$I_d = (1.77 \times 10^{-9} \frac{A}{s})t$$

Example 36.2 Displacement Current in Parallel Capacitor

Problem: Two circular plates of radius 9cm are separated in air by 2.0mm, forming a parallel plate capacitor. A battery is connected across the plates. At a particular time, t_1 , the rate at which the charge is flowing through the battery from one plate to the other is 5A.

- (a) What is the time rate of change of the electric field between the plates at t_1 ?
- (b) Compute the displacement current between the plates at t_1 , and show it is equal to 5A.

Definitions

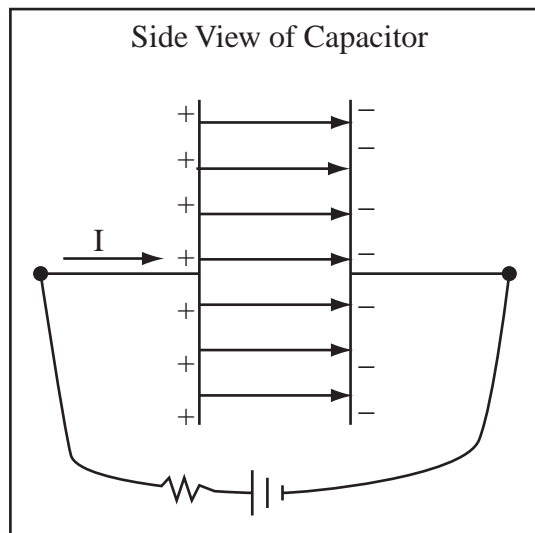

- $I = 5A \equiv$ Current Flowing into Capacitor at t_0
- $t_1 \equiv$ Time of Calculation
- $Q \equiv$ Total Charge on One Plate of Capacitor
- $A \equiv$ Area of Capacitor Plate
- $E \equiv$ Electric field in Capacitor
- $\sigma \equiv$ Surface charge density
- $\phi_e \equiv$ Electric Flux

Strategy: Use the parallel plate capacitor formula for the electric field and identify the current as the time rate of change of the charge on the capacitor plates.

Solution to Part (a)

(a) Compute Electric Field in Capacitor: The electric field in a parallel plate capacitor is given by

$$E = \frac{\sigma}{\epsilon_0}$$

where the surface charge density σ can be related to the total charge Q by $Q = \sigma A$ where A is the area. This gives an electric field of

$$E = \frac{Q}{A\epsilon_0}.$$

In the above expression only Q changes with time, so we can write the derivative of E as

$$\frac{dE}{dt} = \frac{1}{A\epsilon_0} \frac{dQ}{dt}.$$

(b) Equate the Current as Time Rate of Charge: The current is charge per unit time so at any instant the current is

$$I = \frac{dQ}{dt}$$

(c) Substitute and Compute: Substitute the expression for current into the derivative of the electric field,

$$\frac{dE}{dt} = \frac{1}{A\epsilon_0} \frac{dQ}{dt} = \frac{I}{A\epsilon_0}.$$

Substitute and solve using the area of the plates as $A = \pi r^2 = \pi(9\text{cm})^2 = 0.0254\text{m}^2$

$$\frac{dE}{dt} = \frac{I}{A\epsilon_0} = \frac{5A}{(0.0254\text{m}^2)(8.85 \times 10^{-12} \frac{\text{C}^2}{\text{Nm}^2})} = 2.22 \times 10^{13} \frac{\text{V}}{\text{ms}}$$

Solution to Part (b)

Compute the Displacement Current: The displacement current is defined as

$$I_d = \epsilon_0 \frac{d}{dt} \int (\vec{E} \cdot \hat{n}) dA = \epsilon_0 \frac{d\phi_e}{dt}$$

where ϕ_e is the electric flux through a surface enclosing the field. Take the surface over which the integral is done to be parallel and between the plates of the capacitor. The electric flux through this surface is $\phi_e = EA$, since the field is parallel to the normal of the surface. Substituting the expression for E in a parallel plate capacitor gives

$$\phi_e = EA = \frac{Q}{A\epsilon_0} A = \frac{Q}{\epsilon_0}.$$

Substituting this into the expression for displacement current gives

$$I_d = \epsilon_0 \frac{d\phi_e}{dt} = \epsilon_0 \frac{d}{dt} \frac{Q}{\epsilon_0} = \frac{dQ}{dt} = I.$$

So at time t_1 , $I_d = 5A$.

36.2 Visualizing the Induced Electric Field

The displacement current behaves just like a normal current in Ampere's law. If there is no real current, Ampere's law becomes $\int_C \vec{B} \cdot d\vec{\ell} = \mu_0 I_d$. If we have a cylindrically symmetric changing electric field, then I_d is cylindrically symmetric and we can apply the methods we learned for handling cylindrically symmetric current distributions.

Example 36.3 Visualizing Induced Electric Field

Problem: A parallel plate capacitor with circular plates is connected such that it produces an electric field directed out of the page, which increases with time. Draw the magnetic field.

Solution

Strategy: Qualitatively decide on the direction of the displacement current, then use the right hand rule for a wire to get the direction of the magnetic field.

(a) Sketch Circular Paths: Sketch a number of circular paths in the region containing the field, these are the boundaries of the surfaces we will compute the flux through and the Amperian paths along which we will compute the magnetic fields.

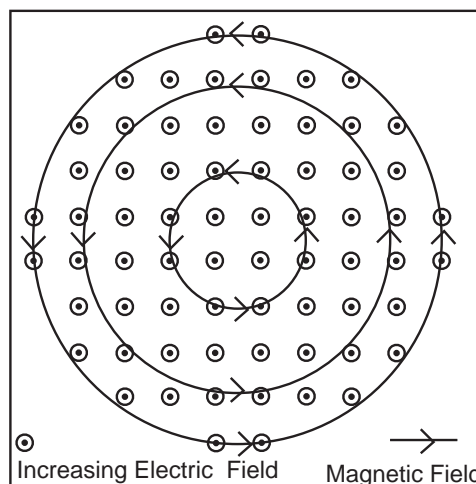

(b) Compute Displacement Current through Surface: In the figure, the field points out of the page. If we compute the electric flux, ϕ_e , with the normal in the direction of the field, then the flux is positive with this normal. Since the field is increasing, $d\phi_e/dt > 0$, the displacement current I_d is directed out of the page.

(c) Reason About Shape of Magnetic Field: Since magnetic field lines must close, and the region is cylindrical, the magnetic field lines must be circles.

(d) Use Right Hand Rule (RHR) for Wire: The displacement current acts like a real current in Ampere's Law (even though no charge is flowing in the region), so we can use the RHR to compute the direction. Since the displacement current points out of the page, the B field is oriented as drawn, by the RHR for a wire.

36.3 Maxwell's Equations

With the addition to Ampere's law, we complete Maxwell's equations, the set of equations that completely describe the behavior of electric and magnetic fields

Gauss' Law :

$$\oint_S (\vec{E} \cdot \hat{n}) dA = \frac{Q_{\text{enclosed}}}{\epsilon_0}$$

"No Magnetic Monopoles" :

$$\oint_S (\vec{B} \cdot \hat{n}) dA = 0$$

Faraday's Law :

$$\oint_C \vec{E} \cdot d\vec{l} = -\frac{d}{dt} \int_S (\vec{B} \cdot \hat{n}) dA$$

Ampere's Law:

$$\oint_C \vec{B} \cdot d\vec{l} = \mu_0 I + \mu_0 \epsilon_0 \frac{d}{dt} \int_S (\vec{E} \cdot \hat{n}) dA$$

With the Lorentz force, $\vec{F} = q\vec{E} + q\vec{v} \times \vec{B}$, the interaction of charges particles and electric and magnetic fields is completely described.

Maxwell's equations are extraordinary in that (up to quantum corrections) they are always absolutely correct. Maxwell's equations have been supported by 100 years of experimentation. Therefore, if you ever encounter a situation that appears to violate a Maxwell's equation, you've blown it. I expect you to be able to name each Maxwell equation and, in words, tell what it means.

Example 36.4 What Does Gauss' Law Mean?

Problem: The following is the first of Maxwell's equations,

$$\oint_S (\vec{E} \cdot \hat{n}) dA = \frac{Q_{\text{enclosed}}}{\epsilon_0}$$

- (a) What is the name of the physical law it represents?
 (b) Explain in words what the equation means.

Solution to Part(a)

Gauss' Law.

Solution to Part(b)

The electric flux through any closed surface is proportional to the net charge enclosed by the surface.

Chapter 37

Electromagnetic Waves

37.1 A Solution to Maxwell's Equation

37.1.1 The Speed of Light

Maxwell's Equations are a set of simultaneous integral equations. We can seek a solution which satisfies all of the equations. What follows may be the most important calculation ever performed. It is however very detailed and you are asked to understand only the results and that the results come from solving Maxwell's equation.

Guess a Solution To solve a set of interlinked integral equations, one must guess a possible solution and check to see if it satisfies each equation. The first guess one makes for a differential system is always a set of sines and cosines. Maxwell's equations depend both on space and time, so we need sine and cosine functions which are functions of both space and time. Sounds like a wave. Let us try the following set of fields in Maxwell's equations:

$$\vec{E}(\vec{r}, t) = E_0 \hat{y} \cos(kx - \omega t)$$

$$\vec{B}(\vec{r}, t) = B_0 \hat{z} \cos(kx - \omega t)$$

These are electromagnetic waves with constant maximum amplitude, E_0 for the electric field and B_0 for the magnetic field. The wavenumber of the wave is k and the angular frequency ω . I have further chosen the direction of the electric field to be \hat{y} and the direction for the magnetic field to be \hat{z} .

Try this solution in each of the Maxwell equations.

Maxwell I - Gauss' Law We need to show that the wave equations satisfy Gauss' law

$$\int_S (\vec{E} \cdot \hat{n}) dA = 0$$

for all Gaussian surfaces S , where I have used $Q = 0$ for a wave propagating in free space, where there is no charge. The figure to the right draws the electric component of the wave and a rectangular Gaussian surface. The figure to the right shows the electric component of the wave at a given time. The side view of a Gaussian surface is shown. The surface is drawn as a rectangle, but is actually a three dimensional parallelepiped. Note the electric field only changes with x . The field has the same x coordinate, no matter what the y and z coordinates are. Examining the Gaussian surface shows that the same flux goes in as comes out, so Gauss' law is satisfied, since the total flux out (zero) equals the total charge enclosed (zero).

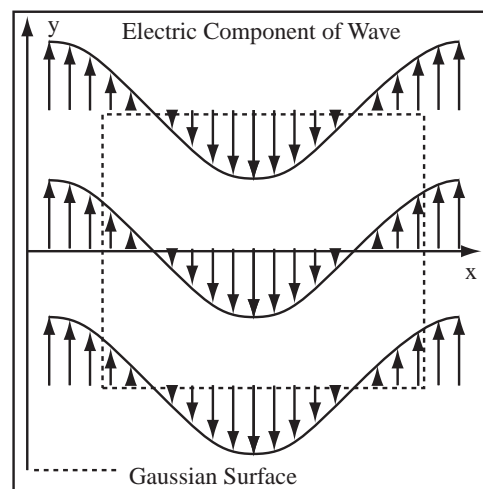

Maxwell II - No Magnetic Monopoles Now apply Maxwell's second equation to the surface shown to the right. The magnetic field looks just like the electric field except the picture to the right shows the $x-z$ plane. The second Maxwell's equation is

$$\int_S (\vec{B} \cdot \hat{n}) dA = 0$$

which in words states that the net magnetic flux out of any surface is zero. The magnetic component of the wave and a Gaussian surface is drawn to the right. The magnetic flux out of the surface is zero, therefore the second Maxwell's equation is satisfied (for this surface).

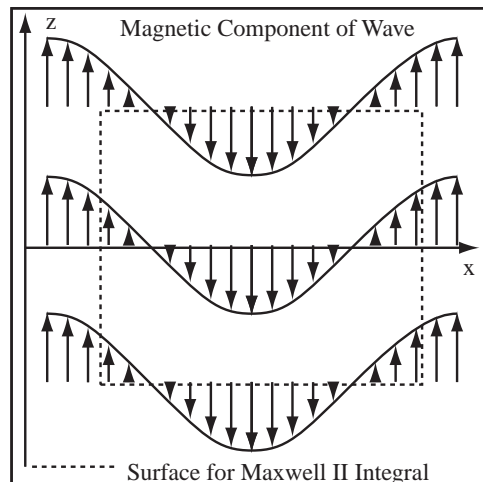

Maxwell III - Faraday's Law Faraday's Law relates the change in magnetic flux through a surface, S , to the integral of the electric field around the curve, C , which bounds the surface.

$$\int_C \vec{E} \cdot d\vec{\ell} = -\frac{d}{dt} \int_S (\vec{B} \cdot \hat{n}) dA$$

Evaluate the two integrals for a path C which is Δx wide and L tall as drawn to the right. The corners of the path are denoted by a, b, c, and d. Both the electric and magnetic fields are drawn to the right. For the curve drawn, $\vec{E} \perp d\vec{\ell}$ on the top and the bottom, so the integral across the top and bottom is zero. The integral around the path is then

$$\int_C \vec{E} \cdot d\vec{\ell} = \int_{b \rightarrow c} \vec{E} \cdot d\vec{\ell} + \int_{d \rightarrow a} \vec{E} \cdot d\vec{\ell}$$

Let the left side of the path be at x_0 from the origin. For $b \rightarrow c$, $d\vec{\ell} = \hat{y} dy$ and $\vec{E} \cdot d\vec{\ell} = E_0 \cos(k(x_0 + \Delta x) + \omega t) dy$. For $d \rightarrow a$, $d\vec{\ell} = -\hat{y} dy$ and $\vec{E} \cdot d\vec{\ell} = -E_0 \cos(kx_0 + \omega t) dy$. Substituting back into the integrals gives,

$$\begin{aligned} \int_C \vec{E} \cdot d\vec{\ell} &= \int_{b \rightarrow c} \vec{E} \cdot d\vec{\ell} + \int_{d \rightarrow a} \vec{E} \cdot d\vec{\ell} \\ \int_C \vec{E} \cdot d\vec{\ell} &= \int_{b \rightarrow c} E_0 \cos(k(x_0 + \Delta x) - \omega t) dy + \int_{d \rightarrow a} -E_0 \cos(kx_0 - \omega t) dy \end{aligned}$$

The cosine may be brought out of the integral because it depends on only x and t .

$$\int_C \vec{E} \cdot d\vec{\ell} = E_0 \cos(k(x_0 + \Delta x) - \omega t) \int_{b \rightarrow c} dy - E_0 \cos(kx_0 - \omega t) \int_{d \rightarrow a} dy$$

The two integrals are just the length of the segments L .

$$\int_C \vec{E} \cdot d\vec{\ell} = E_0 \cos(k(x_0 + \Delta x) - \omega t)L - E_0 \cos(kx_0 - \omega t)L$$

Now compute the flux through the surface bounded by the path. If the path is thin (Δx is small), then the magnetic field does not change much over the slice and the magnetic flux can be approximated by

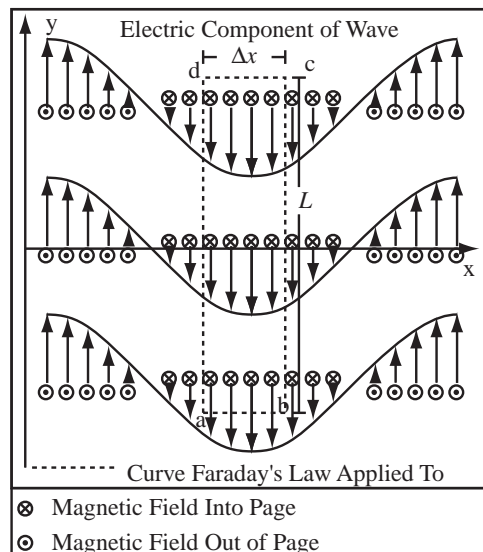

$\phi_m = (\vec{B} \cdot \hat{n})A$. The positive normal for the curve selected is $\hat{n} = \hat{z}$. The area of the surface bounded by the curve is $A = L\Delta x$. The magnetic flux is then

$$\phi_m = (\vec{B} \cdot \hat{n})A = B_0 \hat{z} \cos(kx_0 - \omega t) \cdot \hat{z}(L\Delta x) = B_0 \cos(kx_0 - \omega t)L\Delta x$$

The negative time derivative of the flux is

$$-\frac{d\phi_m}{dt} = -\frac{d}{dt}B_0 \cos(kx_0 - \omega t)L\Delta x = -LB_0\Delta x\omega \sin(kx_0 - \omega t)$$

Substitute everything back into Faraday's law,

$$\int_C \vec{E} \cdot d\vec{\ell} = -\frac{d}{dt} \int_S (\vec{B} \cdot \hat{n})dA$$

$$E_0 \cos(k(x_0 + \Delta x) - \omega t)L - E_0 \cos(kx_0 - \omega t)L = -LB_0\Delta x\omega \sin(kx_0 - \omega t)$$

Cancel L and divide by Δx ,

$$E_0 \frac{\cos(k(x_0 + \Delta x) - \omega t) - \cos(kx_0 - \omega t)}{\Delta x} = -B_0\omega \sin(kx_0 - \omega t)$$

Now let $\Delta x \Rightarrow 0$,

$$E_0 \frac{\cos(k(x_0 + \Delta x) - \omega t) - \cos(kx_0 - \omega t)}{\Delta x} = E_0 \frac{d}{dx} \cos(kx - \omega t) = -E_0 k \sin(kx - \omega t)$$

$$-E_0 k \sin(kx - \omega t) = -B_0\omega \sin(kx_0 - \omega t)$$

So the wave equations satisfy Faraday's law if

$$E_0 k = B_0 \omega$$

Maxwell IV - Ampere's Law Now try the wave equations in Ampere's law,

$$\int_C \vec{B} \cdot d\vec{\ell} = \mu_0 I + \mu_0 \varepsilon_0 \frac{d}{dt} \int_S (\vec{E} \cdot \hat{n})dA$$

There is no current flowing in the region, therefore

$$\int_C \vec{B} \cdot d\vec{\ell} = \mu_0 \varepsilon_0 \frac{d}{dt} \int_S (\vec{E} \cdot \hat{n})dA$$

This relation looks very much like Faraday's law with the electric and magnetic fields exchanged. We can use the same method on the path drawn to the right as was used for Faraday's law.

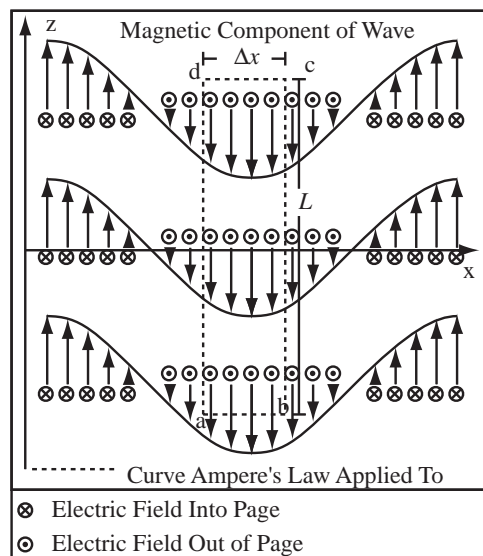

Evaluate the two integrals for a path C which is Δx wide and L tall as drawn to the right. The corners of the path are denoted by a, b, c, and d. Both the electric and magnetic fields are drawn above. For the curve drawn, $\vec{B} \perp d\vec{\ell}$ on the top and the bottom, so the integral across the top and bottom is zero. The integral around the path is then

$$\int_C \vec{B} \cdot d\vec{\ell} = \int_{b \rightarrow c} \vec{B} \cdot d\vec{\ell} + \int_{d \rightarrow a} \vec{B} \cdot d\vec{\ell}$$

Let the left side of the path be at x_0 from the origin. For $b \rightarrow c$, $d\vec{\ell} = \hat{z}dz$ and $\vec{B} \cdot d\vec{\ell} = B_0 \cos(k(x_0 + \Delta x) + \omega t)dz$. For $d \rightarrow a$, $d\vec{\ell} = -\hat{z}dz$ and $\vec{B} \cdot d\vec{\ell} = -B_0 \cos(kx_0 + \omega t)dz$. Substituting back into the integrals gives,

$$\int_C \vec{B} \cdot d\vec{\ell} = \int_{b \rightarrow c} \vec{B} \cdot d\vec{\ell} + \int_{d \rightarrow a} \vec{B} \cdot d\vec{\ell}$$

$$\int_C \vec{B} \cdot d\vec{\ell} = \int_{b \rightarrow c} B_0 \cos(k(x_0 + \Delta x) - \omega t) dz + \int_{d \rightarrow a} -B_0 \cos(kx_0 - \omega t) dz$$

The cosine may be brought out of the integral because it depends on only x and t .

$$\int_C \vec{E} \cdot d\vec{\ell} = B_0 \cos(k(x_0 + \Delta x) - \omega t) \int_{b \rightarrow c} dz - B_0 \cos(kx_0 - \omega t) \int_{d \rightarrow a} dz$$

The two integrals are just the length of the segments L .

$$\int_C \vec{B} \cdot d\vec{\ell} = B_0 \cos(k(x_0 + \Delta x) - \omega t)L - B_0 \cos(kx_0 - \omega t)L$$

Now compute the electric flux through the surface bounded by the path. If the path is thin (Δx is small), then the electric field does not change much over the slice and the electric flux can be approximated by $\phi_e = (\vec{E} \cdot \hat{n})A$. For a positive normal for the curve selected $\hat{n} = -\hat{y}$. The area of the surface bounded by the curve is $A = L\Delta x$. The electric flux is then

$$\phi_e = (\vec{E} \cdot \hat{n})A = E_0 \hat{y} \cos(kx_0 - \omega t) \cdot (-\hat{y})(L\Delta x) = -E_0 \cos(kx_0 - \omega t)L\Delta x$$

The time derivative of the electric flux is

$$\frac{d\phi_e}{dt} = \frac{d}{dt}(-E_0) \cos(kx_0 - \omega t)L\Delta x = -LE_0\Delta x\omega \sin(kx_0 - \omega t)$$

Substitute everything back into Ampere's law,

$$\int_C \vec{B} \cdot d\vec{\ell} = \mu_0 \varepsilon_0 \frac{d}{dt} \int_S (\vec{E} \cdot \hat{n}) dA$$

$$B_0 \cos(k(x_0 + \Delta x) - \omega t)L - B_0 \cos(kx_0 - \omega t)L = \mu_0 \varepsilon_0 LE_0 \Delta x \omega \sin(kx_0 - \omega t)$$

Cancel L and divide by Δx ,

$$E_0 \frac{\cos(k(x_0 + \Delta x) - \omega t) - \cos(kx_0 - \omega t)}{\Delta x} = -\mu_0 \varepsilon_0 E_0 \omega \sin(kx_0 - \omega t)$$

Now let $\Delta x \Rightarrow 0$,

$$\begin{aligned} B_0 \frac{\cos(k(x_0 + \Delta x) - \omega t) - \cos(kx_0 - \omega t)}{\Delta x} &= B_0 \frac{d}{dx} \cos(kx - \omega t) = -B_0 k \sin(kx - \omega t) \\ -B_0 k \sin(kx - \omega t) &= -\mu_0 \varepsilon_0 E_0 \omega \sin(kx_0 - \omega t) \end{aligned}$$

So the wave equations must also satisfy

$$B_0 k = \mu_0 \varepsilon_0 E_0 \omega$$

Solve for Wave Velocity Substituting our test wave equations into Maxwell's equations has yielded two equations that the wavenumber, angular frequency, and the magnitude of the electric and magnetic field must satisfy for the waves to be a solution of Maxwell's equations:

$$B_0 k = \mu_0 \varepsilon_0 E_0 \omega$$

$$E_0 k = B_0 \omega$$

Rearrange the second equation to yield,

$$E_0 = \frac{\omega}{k} B_0.$$

Substitute back into the first equation,

$$B_0 k = \mu_0 \varepsilon_0 \frac{\omega}{k} B_0 \omega$$

Cancel B_0 and rearrange,

$$\frac{1}{\mu_0 \varepsilon_0} = \left(\frac{\omega}{k} \right)^2$$

$$\sqrt{\frac{1}{\mu_0 \epsilon_0}} = \frac{\omega}{k}$$

The quantity $\frac{\omega}{k} = \lambda f$ is the speed of the wave

$$\frac{\omega}{k} = \lambda f = v = \frac{1}{\sqrt{\mu_0 \epsilon_0}}$$

where λ is the wavelength, f is the frequency, and v is the wave velocity. Therefore, to be an electromagnetic wave, the wave must travel at a velocity $v = \frac{1}{\sqrt{\mu_0 \epsilon_0}}$

A second result, not as important, but somewhat unusual, is found by substituting back into the second relation derived from Maxwell equation

$$E_0 = B_0 \frac{\omega}{k} = B_0 \frac{1}{\sqrt{\mu_0 \epsilon_0}} = v B_0$$

Therefore, the magnitude of the electric component of an electromagnetic wave is the velocity of the wave multiplied by the magnitude of the magnetic component.

37.1.2 For Cal III People Only

Well that was a pain. If you have had enough Cal III to understand div, grad, and curl, the result becomes much easier. If you have not had Cal III skip this section. Using div, grad, and curl we can restate Maxwell's equations,

$$\nabla \cdot \vec{E} = \frac{\rho}{\epsilon_0} \quad \text{Gauss' Law}$$

$$\nabla \cdot \vec{B} = 0 \quad \text{No Magnetic Monopoles}$$

$$\nabla \times \vec{E} = -\frac{\partial \vec{B}}{\partial t} \quad \text{Faraday's Law}$$

$$\nabla \times \vec{B} = \mu_0 \vec{j} + \epsilon_0 \mu_0 \frac{\partial \vec{E}}{\partial t} \quad \text{Ampere's Law}$$

where ρ is the volume charge density and \vec{j} is the current density.

If there are not free charges or currents, the equations have a nicely symmetric form.

$$\begin{aligned} \nabla \cdot \vec{E} &= 0 & \nabla \cdot \vec{B} &= 0 \\ \nabla \times \vec{E} &= -\frac{\partial \vec{B}}{\partial t} & \nabla \times \vec{B} &= \epsilon_0 \mu_0 \frac{\partial \vec{E}}{\partial t} \end{aligned}$$

Take the curl of Ampere's law

$$\nabla \times \nabla \times \vec{B} = \epsilon_0 \mu_0 \frac{\partial \nabla \times \vec{E}}{\partial t}$$

Substitute Faraday's law,

$$\nabla \times \nabla \times \vec{B} = -\epsilon_0 \mu_0 \frac{\partial^2 \vec{B}}{\partial t^2}$$

The curl has the property that $\nabla \times (\nabla \times \vec{A}) = \nabla(\nabla \cdot \vec{A}) - \nabla^2 \vec{A}$, so

$$\nabla \times \nabla \times \vec{B} = \nabla(\nabla \cdot \vec{B}) - \nabla^2 \vec{B} = -\epsilon_0 \mu_0 \frac{\partial^2 \vec{B}}{\partial t^2}$$

or if we use $\nabla \cdot \vec{B} = 0$,

$$\nabla^2 \vec{B} = \epsilon_0 \mu_0 \frac{\partial^2 \vec{B}}{\partial t^2}$$

So each component of the magnetic field satisfies an equation like

$$\frac{\partial^2 B_x}{\partial x^2} - \epsilon_0 \mu_0 \frac{\partial^2 B_x}{\partial t^2} = 0$$

This kind of equation is called a wave equation and its solutions are of the form $\sin(kx - \omega t)$. The waves have speed $1/\sqrt{\epsilon_0 \mu_0}$. To me this is tons easier than the derivation in the previous section.

37.2 Electromagnetic Waves

37.2.1 Let There Be Light

So you're Maxwell and you've just proved that electromagnetic waves exist and propagate through space with velocity $v = \frac{1}{\sqrt{\mu_0 \epsilon_0}}$. So naturally, you punch $\frac{1}{\sqrt{\mu_0 \epsilon_0}}$ into your calculator and find

$$v = \frac{1}{\sqrt{\mu_0 \epsilon_0}} = \frac{1}{\sqrt{(4\pi \times 10^{-7} \frac{\text{Tm}}{\text{A}})(8.85 \times 10^{-12} \frac{\text{C}^2}{\text{Nm}^2})}} = 3 \times 10^8 \frac{\text{m}}{\text{s}}$$

which is the speed of light.

Speed of Light in Vacuum: The speed of light in vacuum is denoted by the symbol c and is always $c = 3 \times 10^8 \frac{\text{m}}{\text{s}}$.

The velocity of an electromagnetic wave, computed from Maxwell's equations and the universal constants ϵ_0 and μ_0 is the speed of light, c . Therefore, light is an electromagnetic wave!!!! In this class, you have measured both ϵ_0 and μ_0 and have mastered the techniques to carry out the above calculation, so you can show this crucial insight about the universe.

Light is an Electromagnetic Wave: Light, the everyday phenomena that allows us to see stuff, is actually an electromagnetic wave formed of crossed electric and magnetic fields.

All of a sudden, electricity and magnetism is unified with optics and we're on the slippery slope to relativity and quantum mechanics. Every once in a while in science, you have a moment where the universe breaks apart and reforms before your eyes.

37.2.2 Summary of the Results of the Wave Solution to Maxwell's Equations

The results of the calculation of the speed of light can be generalized to yield the following important properties of an electromagnetic wave, light.

Speed of Electromagnetic (EM) Waves: There is a solution to Maxwell's Equations which is a travelling wave, with velocity that of the speed of light. The speed of light, c , is related to the constants in Maxwell's Equations by

$$c = \frac{1}{\sqrt{\mu_0 \epsilon_0}} \cong 3 \times 10^8 \frac{\text{m}}{\text{s}}$$

This is the speed of light in vacuum, the velocity is reduced in a material.

Relation of Electric and Magnetic Field Magnitudes in an EM Wave for a Plane Wave in a Vacuum : The magnitude of the electric and magnetic fields in the wave solution of Maxwell's Equations are related by

$$|\vec{E}| = c|\vec{B}|$$

The Poynting Vector : The Poynting vector, \vec{S} , is defined as

$$\vec{S} \equiv \frac{\vec{E} \times \vec{B}}{\mu_0}$$

Propagation Direction of an EM Wave : The direction that an EM wave travels is the same as the direction of the Poynting vector, \vec{S} .

All Components Perpendicular: The electric and magnetic components of an electromagnetic wave are perpendicular. Both components are perpendicular to the propagation direction given by the Poynting vector.

Example 37.1 Draw an Electromagnetic Wave

Problem: Draw an electromagnetic wave where the electric field obeys $\vec{E} = E_0\hat{y}\cos(kx - \omega t)$ and the magnetic field obeys $\vec{B} = B_0\hat{z}\cos(kx - \omega t)$.

Solution

Strategy: Represent the wave as a series of arrows, use the Poynting vector for the direction of propagation.

(a) Think About Real Wave: A plane wave fills space producing an oscillating electric and magnetic field everywhere. We can't draw this. What we can draw is the magnitude of the electric and magnetic field along the coordinate axis in the direction of propagation.

(b) Compute Direction of Propagation: Use the Poynting vector to compute the direction of the other field component or the direction of propagation if given both \vec{E} and \vec{B} .

(c) Draw the Wave: Draw oscillating electric and magnetic fields as in the figure, making sure that $\vec{E} \times \vec{B}$ points in the direction of propagation and that the spacing of the crests is the wavelength.

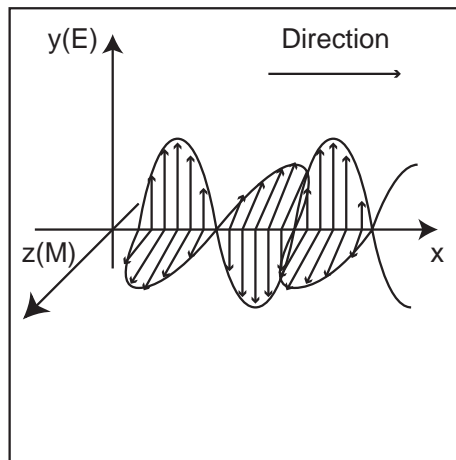
**Example 37.2 Electromagnetic fields in space**

Problem: At $t = 0$, we measure the electric and magnetic components of an electromagnetic wave at some point. The electric field component is $\vec{E} = 100\text{N/C}\hat{x}$ and the magnetic field points in the $+\hat{z}$ direction.

- (a) What is the magnitude of the magnetic field at $t = 0$ at the point where the electric field was measured?
- (b) What is the Poynting vector?
- (c) What is the direction of propagation?

Solution to Part(a)

The magnitude of the magnetic component of an electromagnetic wave is related to the magnitude of the electric component by

$$B = \frac{E}{c} = \frac{100\frac{\text{N}}{\text{C}}}{3 \times 10^8\frac{\text{m}}{\text{s}}} = 3.33 \times 10^{-7}\text{T}.$$

Solution to Part(b)

The Poynting vector is defined as

$$\vec{S} = \frac{\vec{E} \times \vec{B}}{\mu_0} = \frac{(100 \frac{\text{N}}{\text{C}} \hat{x}) \times (3.33 \times 10^{-7} \text{T} \hat{z})}{4\pi \times 10^{-7} \frac{\text{Tm}}{\text{A}}} = 26.5 \frac{\text{W}}{\text{m}^2} (\hat{x} \times \hat{z}).$$

The cross product $\hat{x} \times \hat{z}$ can be evaluated using the Right Hand Rule, $\hat{x} \times \hat{z} = -\hat{y}$.

$$\vec{S} = -26.5 \frac{\text{W}}{\text{m}^2} \hat{y}$$

Solution to Part(c)

The wave propagates in the direction of the Poynting vector. Therefore, the wave propagates in the $-\hat{y}$ direction.

37.2.3 Features of Moving Waves

Let's review some features of travelling waves from UPI.

Equation of a Moving Wave: Waves that move in a single direction vary in both space, x , and time, t . The equation for a wave which varies sinusoidally is

$$h(x, t) = A_{max} \sin(kx - \omega t + \delta)$$

where A_{max} is the maximum amplitude, k is the wave number, ω is the angular frequency, and δ is the phase difference. The amplitude of the wave at any specified point in space and time is $h(x, t)$. A_{max} is the maximum amplitude of the wave as measured from its average amplitude (this is always positive).

Period and Frequency: The period, T , is the time between successive crests of the wave. The frequency, f is the number of full waves in a unit time, and is related to the period by

$$f = 1/T$$

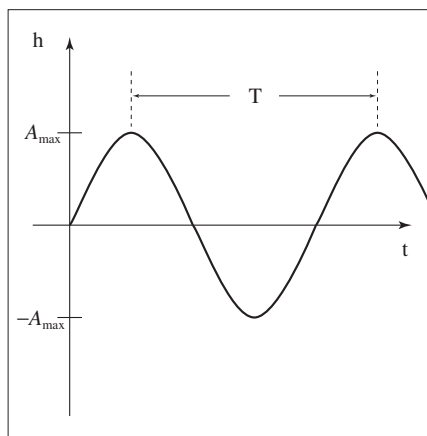

Units of Frequency: Frequency is measured in Hertz,

$$1\text{Hz} = 1\text{s}^{-1}$$

Frequency and Angular Frequency: The frequency, f , of a wave has a circular analog called the angular frequency, ω , defined as

$$\omega = 2\pi f$$

The angular frequency is the time rate of change of the argument of the sine function representing the wave.

Wavelength and Wave Number:

The wavelength, λ , is the distance between successive crests of the wave. The wavenumber, k , is related to the number of full waves in a unit distance, and is related to the wavelength by

$$k = 2\pi/\lambda$$

It is the position rate of change of the argument of the sine function representing the wave.

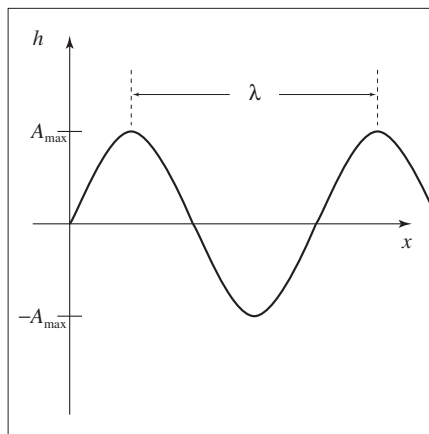

Speed of a Moving Wave: The speed, v_{wave} , of any moving wave is related to its wavelength, λ , and frequency, f , by

$$v_{wave} = \lambda f = \frac{\omega}{k}$$

Example 37.3 Using the Wave Velocity Equation

Problem: A laser produces light at a wavelength of 500nm.

- (a) What is the speed of laser light?
 (b) What is the frequency of the light wave?

Solution to Part(a)

The speed of light in a vacuum is $c = 3 \times 10^8 \frac{\text{m}}{\text{s}}$.

Solution to Part(b)

The frequency of light is given by $f = c/\lambda = 3 \times 10^8 \frac{\text{m}}{\text{s}} / 5 \times 10^{-7} \text{m} = 6 \times 10^{14} \text{Hz}$.

Example 37.4 Writing a Wave Equation Based on a Graph

Problem: The amplitude of a wave at $t = 0$ is shown below. It takes two seconds for the wave to complete a cycle. Write an equation for the wave. Give a numerical value for each constant you introduce.

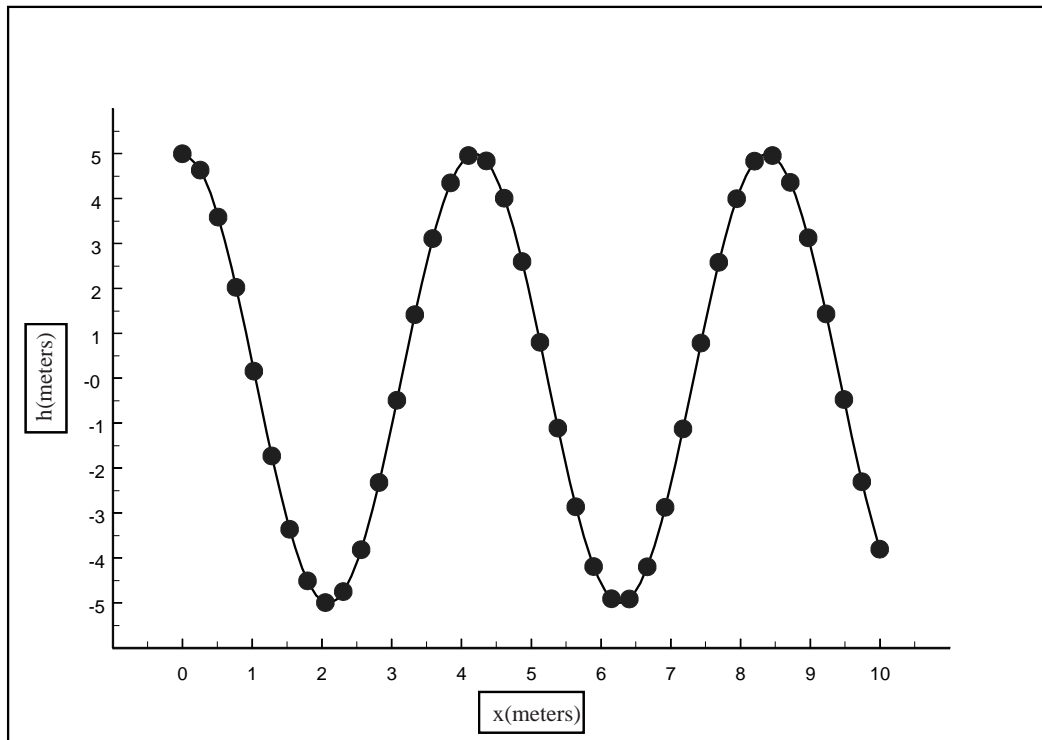

Solution

The period of the wave is given as $T = 2\text{s}$ and therefore the frequency is $f = 1/T = 0.5\text{Hz}$ and the angular frequency $\omega = 2\pi f = \pi\text{s}^{-1}$. The wavelength, which can be read off the graph, is $\lambda = 4\text{m}$, which gives a wavenumber $k = 2\pi/\lambda = 0.5\pi\text{m}^{-1}$ and the wave has a maximum at $x = 0$, so it is a cosine wave, a sine wave with phase difference $\delta = \frac{\pi}{2}$. The amplitude of the wave can be read from the graph.

$$h(x, t) = A \sin(kx - \omega t + \frac{\pi}{2}) = A \cos(\frac{2\pi}{\lambda}x - 2\pi ft) = (5\text{m}) \cos((0.5\pi\text{m}^{-1}x) - (\pi\text{s}^{-1}t))$$

Note how the units cancel in the argument of the cosine function.

37.2.4 The Spectrum

All light waves are electromagnetic waves. Different wavelengths are used for different purposes. The collection of all frequencies and wavelength is called the electromagnetic spectrum. The important features of the electromagnetic spectrum are summarized in the table below. Note the units on the wavelengths.

Name	Wavelength	Frequency(Hz)
AM Radio	600m – 200m	$5 \times 10^5 \text{Hz} - 1.5 \times 10^6 \text{Hz}$
Short Wave Radio	187m – 5.55m	$1.6 \times 10^6 \text{Hz} - 5.4 \times 10^7 \text{Hz}$
TV and FM Radio	5.55m – 0.187m	$5.4 \times 10^7 \text{Hz} - 1.6 \times 10^9 \text{Hz}$
Microwaves and Radar	187mm – 10mm	$1.6 \times 10^9 \text{Hz} - 3 \times 10^{10} \text{Hz}$
Millimeter waves and telemetry	10mm – 1mm	$3 \times 10^{10} \text{Hz} - 3 \times 10^{11} \text{Hz}$
Infrared	1mm – 750nm	$3 \times 10^{11} \text{Hz} - 4 \times 10^{14} \text{Hz}$
Visible	750nm – 400nm	$4 \times 10^{14} \text{Hz} - 7.5 \times 10^{14} \text{Hz}$
Visible(Red)	750nm – 625nm	
Visible(Orange)	625nm – 590nm	
Visible(Yellow)	590nm – 565nm	
Visible(Green)	565nm – 520nm	
Visible(Cyan)	520nm – 500nm	
Visible(Blue)	500nm – 435nm	
Visible(Violet)	435nm – 400nm	
Ultraviolet	400nm – 10nm	$7.5 \times 10^{14} \text{Hz} - 3 \times 10^{16} \text{Hz}$
X-Rays	< 10nm	$> 3 \times 10^{16} \text{Hz}$
Gamma-Rays	< $1 \times 10^{-12} \text{m}$	$> 1 \times 10^{20} \text{Hz}$

The government of a country owns the rights to the electromagnetic spectrum in the region bounded by the international borders of the country and can sell licenses to use that spectrum to companies wishing to use electromagnetic waves of a given wavelength for communication. A 700MHz = $7 \times 10^8 \text{Hz}$ wide chunk of the television and microwave spectrum to be used for high speed wireless devices is expected to fetch 2.6 billion dollars for the US government.

37.3 Mechanical Properties

Electromagnetic waves carry energy from place to place in their electric and magnetic fields. The energy in a beam of light is just the energy stored in the electric and magnetic fields and this energy moves at the speed of light. The intensity of a beam of light is the energy crossing a unit area per unit time and measures the rate at which energy is transferred.

Definition of Intensity: The intensity, $I(t)$, of a wave is the energy, $U(t)$, crossing a unit area, A , per unit time. This is the same as power, $P(t)$, per unit area,

$$I(t) = \frac{U(t)}{At} = \frac{P(t)}{A}$$

Units of Intensity: The SI units for intensity are

$$\frac{\text{J}}{\text{m}^2\text{s}} \quad \text{or} \quad \frac{\text{W}}{\text{m}^2}.$$

The intensity changes as the electric and magnetic fields of the wave oscillate. The intensity is the energy density in the field multiplied by the velocity of the wave, c , $I(t) = uc$, where u is the total energy density. The total energy density is the sum of the electric energy density, $u_e = \frac{1}{2}\epsilon_0|\vec{E}|^2$ and the magnetic energy density, $u_m = \frac{|\vec{B}|^2}{2\mu_0}$. Therefore the intensity is

$$I(t) = \frac{1}{2} \left(\epsilon_0 |\vec{E}|^2 + \frac{|\vec{B}|^2}{\mu_0} \right) c$$

Using $E = cB$ and $c = 1/\sqrt{\epsilon_0\mu_0}$ this can be rewritten,

$$I(t) = c \frac{|\vec{B}|^2}{\mu_0} = c \frac{B_0^2}{\mu_0} \sin^2(kx - \omega t)$$

Light waves oscillate vary rapidly, so rapidly that we don't notice the instantaneous changes in intensity, so it is more useful to know the average intensity, I_{ave} . If we average the intensity over one period, T , we find

$$I_{ave} = \int_0^T I(t)dt = c \frac{B_0^2}{2\mu_0}$$

We will drop the ave and write $I = I_{ave}$.

Average Intensity: In general, when we say intensity, we are referring to the average intensity of an electromagnetic wave. The average intensity is the intensity averaged over one period of the wave. If we ever mean the instantaneous intensity, we will explicitly say so.

Intensity of an EM Wave : The average intensity, I , of an EM wave can be related to the average magnitude of the Poynting vector

$$I = |\vec{S}_{ave}|$$

or to the maximum amplitude of the electric \vec{E}_0 and magnetic B_0 fields

$$I = \frac{\vec{E}_0^2}{2\mu_0 c} = \frac{c\vec{B}_0^2}{2\mu_0} = \frac{c\varepsilon_0 \vec{E}_0^2}{2}$$

A number of other expressions are possible using $c = \frac{1}{\sqrt{\varepsilon_0\mu_0}}$ and $E = cB$.

Light waves also carry momentum. For light the total energy in the wave E_{TOT} is related to the total momentum, p , by $p = E_{TOT}/c$. The intensity divided by the speed of light is the momentum per unit area per unit time transferred by the wave. If the light falls on a surface, I/c momentum per unit time is transferred to the surface per unit surface area. But momentum transfer per time is force, so I/c force per unit area is exerted on the surface by the light wave. We call force per unit area, pressure.

Radiation Pressure : If an EM wave is normally incident on a surface which totally absorbs it, then the wave exerts a pressure, P_r , related to the intensity, I , of the wave

$$P_r = I/c$$

If the radiation is completely reflected, then the radiation pressure is doubled. If it is incident at an angle to the surface, only the normal component "pushed".

Example 37.5 Intensity of KUAF Signal

Problem: Assume the local public radio station KUAF radiates 50000W of power in radio waves uniformly in all directions (in a uniform sphere).

- What is the intensity of the waves at 1km = 1000m from the station?
- What is the maximum amplitude of the electric field at 1km from the station?
- What is the maximum amplitude of the magnetic field at 1km?

Solution to Part(a)

Intensity, I , is power, P , per unit area; so divide the total power by the surface area of a sphere with radius $r = 1000\text{m}$.

$$I = \frac{P}{4\pi r^2} = \frac{50000\text{W}}{4\pi(1000\text{m})^2} = 3.98 \times 10^{-3} \frac{\text{W}}{\text{m}^2}$$

Solution to Part(b)

The intensity is related to the magnitude of the electric component of the field by $I = \frac{1}{2}c\epsilon_0 E_0^2$, where E_0 is the amplitude of the electric field. So for the field,

$$E_0 = \sqrt{\frac{2I}{c\epsilon_0}} = \sqrt{\frac{2(3.98 \times 10^{-3} \frac{\text{W}}{\text{m}^2})}{(3 \times 10^8 \frac{\text{m}}{\text{s}})(8.85 \times 10^{-12} \frac{\text{C}^2}{\text{Nm}^2})}} = 1.73 \frac{\text{N}}{\text{C}}.$$

Solution to Part(c)

The magnetic field, B_0 , in an EM wave is related to the electric field by $B_0 = E_0/c = 1.73 \frac{\text{N}}{\text{C}} / 3 \times 10^8 \frac{\text{m}}{\text{s}} = 5.77 \times 10^{-9} \text{T}$.

37.4 Antennae for EM Waves

In general, an antenna can be a source (transmitter) or a detector (receiver) of EM waves. This section discusses antennae, which detect the electric or magnetic components of an electromagnetic wave. Electromagnetic waves are useful in the form of radio and microwaves for the transmission of information. An antenna is used to detect the waves. The antenna produces an EMF across its terminals that changes with the amplitude of the wave. The techniques we have already developed can be used to select antenna that detect either the magnetic or electric component of the wave.

Match Wave Component with

Antenna : Antenna can be constructed to detect either the magnetic or electric component of an electromagnetic wave. A dipole antenna (a) detects the electric potential difference between its two arms. A loop antenna (b) detects the EMF generated by a changing magnetic flux.

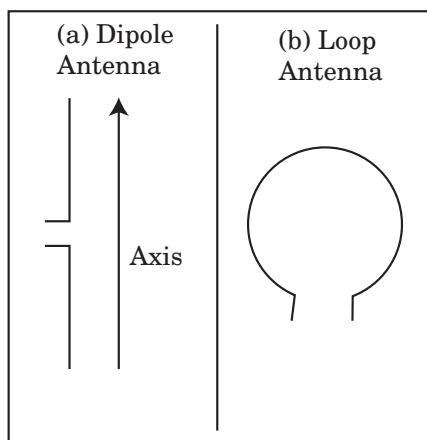

Align Dipole Antenna for Maximum Reception : The antenna will generate the maximum signal when the greatest potential difference exists between the two pieces of the antenna. The maximum potential difference occurs when the axis of the antenna (as shown above) aligns with the electric field of the wave.

Align Loop Antenna for Maximum Reception : For maximum signal, we need maximum induced EMF in the loop, thus maximum change in magnetic flux, so the magnetic field of the electromagnetic wave must align with the normal of the surface enclosed by the loop.

Example 37.6 Selecting Antennae

Problem: An electromagnetic wave has electric field $\vec{E}(t) = 100 \text{N/C} \sin(\omega t) \hat{y}$ and magnetic field $|\vec{B}(t)| = |\vec{E}|/c \hat{z}$.

- What kind of antenna would you use to detect the electric field of this wave?
- How would you place the antenna for maximum reception of the electric component of the wave?
- What kind of antenna would you use to detect the magnetic field of this wave?

- (d) How would you place the antenna for maximum reception of the magnetic component of the wave?

Solution to Part(a)

Since the electric field causes a force (and therefore a potential difference) in the direction of the field, a dipole antennae is best.

Solution to Part(b)

The antenna's axis should be parallel to the electric field, in the \hat{y} direction.

Solution to Part(c)

Since the electric potential difference here is caused by a changing flux through an area, a loop works best.

Solution to Part(d)

To maximize the changing flux, you want the normal of the loop along the magnetic field in the \hat{z} direction. Therefore the loop should lie in the $x - y$ plane.

Example 37.7 Compute EMF for Loop Antenna

Problem: A loop antenna with radius 20cm is aligned for maximum reception to a changing magnetic field $B(t) = 2.0 \times 10^{-9}\text{T} \sin((12.6\text{s}^{-1})t)$. Compute the induced EMF as a function of time.

Solution

Strategy: Compute the flux as a function of time, then apply Faraday's Law to get the EMF.

(a) Sketch Wave and Antenna: Sketch the electromagnetic wave and the antenna correctly oriented for maximum reception, so the magnetic field aligns with the normal of the loop. Maximum reception is when the plane of the loop is perpendicular to the magnetic field.

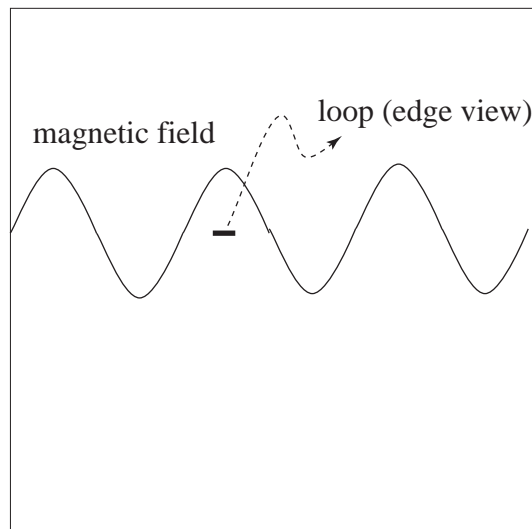

(b) Compute Magnetic Flux through Loop: Compute the flux, $\phi_m(t)$, as a function of time assuming the wave changes little over the area of the loop, so $\phi_m = A|\vec{B}(t)|$, where A is the area of the loop and $|\vec{B}(t)|$ is the magnitude of the field. The area of the loop is $A = \pi r^2 = 0.13\text{m}^2$. The flux is then

$$\phi_m = A|\vec{B}(t)| = 2.6 \times 10^{-10}\text{Wb} |\sin((12.6\text{s}^{-1})t)|$$

(c) Apply Faraday's Law Technique: Compute Induced EMF using

$$emf = -\frac{d\phi_m}{dt}$$

Find the magnitude of the emf

$$\begin{aligned}
 emf &= \left| -\frac{d\phi_m}{dt} \right| \\
 &= 2.6 \times 10^{-10} \text{Wb} \left| \frac{d}{dt} [\sin(12.6\text{s}^{-1}t)] \right| \\
 &= (12.6\text{s}^{-1}) \cdot 2.6 \times 10^{-10} \text{Wb} |\cos(12.6\text{s}^{-1}t)| \\
 |emf| &= 3.3 \times 10^{-9} \text{V} |\cos((12.6\text{s}^{-1})t)|
 \end{aligned}$$

37.5 Polarization

Light is an electromagnetic wave and is described by the propagation of oscillating electric and magnetic fields. The polarization of a wave is usually expressed by the direction of the oscillating electric field vector; if the electric field oscillates in a plane the wave is said to be linearly polarized. Light can easily be a collection of electromagnetic waves with random polarizations. Such light is unpolarized.

37.5.1 Polarization

For most light, the direction of the electric vectors is random, changing with time and from place to place in the wave. By passing the light wave through a polarizer, we can arrange for the electric vector to oscillate in a single direction like the \hat{x} direction. The simplest polarizer is regular array of conducting wires, as shown below. If a light wave with random electric vector is incident on the polarizer as in figure (a), the component of the electric field parallel to the wire, \vec{E}_{\parallel} causes charge to flow and loses energy. Therefore, after passing through the polarizer as in figure (a), only the component of the electric field perpendicular to the wire survives, \vec{E}_{\perp} .

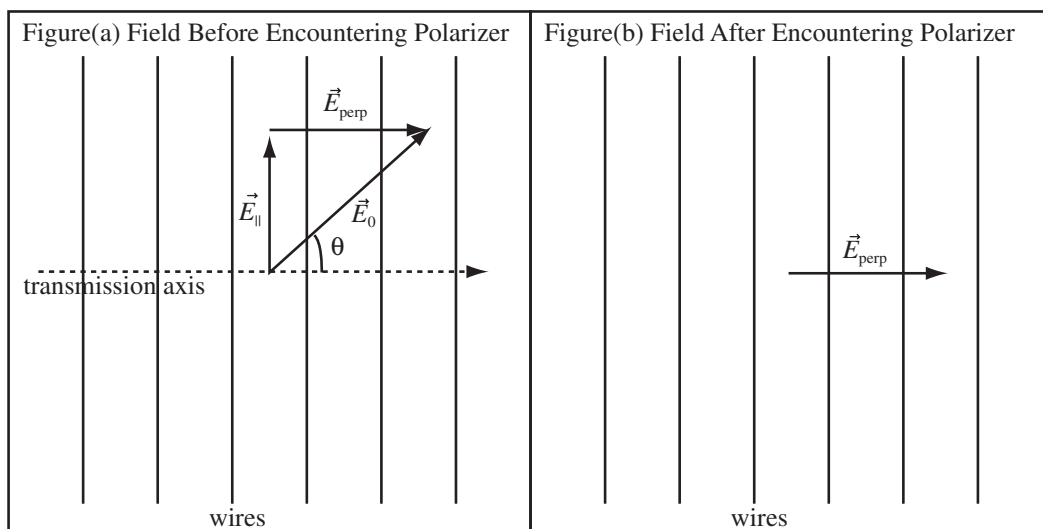

Polarization Direction (Convention): The axis of polarization is defined by convention to be the axis along which the electric field is oscillating.

Unpolarized Light: Unpolarized light has multiple polarizations in random directions.

Transmission Axis: The transmission axis of the polarizer is the direction of polarized light produced by the polarizer.

We can use the above picture to determine how the intensity of the light wave is affected as it passes through the polarizer. The magnitude of the electric field changes from E_0 to $E_0 \cos \theta$, where θ is the angle between the incident field and the transmission axis. Since the magnetic field is proportional to the electric field and both the magnetic and electric energy density depends on the square of the field, the intensity changes from I_0 to $I_0 \cos^2 \theta$. If unpolarized light is shined on a polarizer, polarized light of half the initial intensity is produced.

Malus' Law: Consider polarized light of a certain intensity, I_i , incident at a certain angle, β , to the transmission axis of a polarizer. The intensity of light transmitted through the polarizer I_t is given by Malus' Law

$$I_t = I_i \cos^2 \beta$$

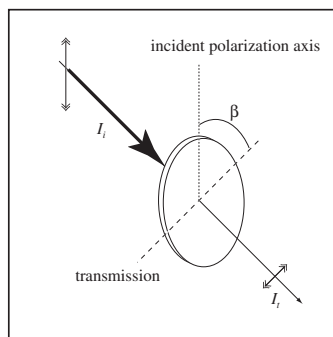

Unpolarized Light Halved by Polarizer: With a bit of calculus, we find that the transmitted intensity for initially *unpolarized light* is half that of the incoming light.

Example 37.8 Three Polarizers

Problem: Two polarizing sheets have their transmission axes crossed so that no light gets through. A third sheet is inserted between the first two such that its transmission axis makes an angle θ with that of the first sheet. Unpolarized light of intensity $0.2 \frac{\text{mW}}{\text{m}^2}$ is incident on the first sheet. Find the intensity of the light transmitted through all three sheets if

- (a) $\theta = 15^\circ$ and
 (b) $\theta = 75^\circ$.

Solution to Part(a)

If the middle sheet makes an angle $\theta_1 = 15^\circ$ with the first sheet, it makes an angle $\theta_2 = 90^\circ - \theta_1 = 75^\circ$ with the second sheet since the two outside polarizers must be at an angle of 90° with each other. A polarizer reduces the intensity of unpolarized light by a factor of 2, so if I_0 is the intensity of the light shining on the first, then $I_1 = I_0/2$ reaches the middle polarizer. The middle polarizer transmits light of an intensity $I_2 = I_1 \cos^2(\theta_1)$. The third polarizer transmits $I_3 = I_2 \cos^2(\theta_2)$. So in terms of the incident intensity

$$I_3 = I_0 \frac{\cos^2(\theta_1) \cos^2(\theta_2)}{2} = (2 \times 10^{-4} \frac{\text{W}}{\text{m}^2}) \frac{\cos^2(15^\circ) \cos^2(75^\circ)}{2} = 6.25 \times 10^{-6} \frac{\text{W}}{\text{m}^2}$$

Solution to Part(b)

The answer is the same as above since $75^\circ + 15^\circ = 90^\circ$. This just shines the light through the polarizer state in (a) from the other side.

37.5.2 Polarization Mechanisms

So how do we get polarized light. There are a number of natural and artificial ways to produce polarized light.

Polarization by transmission Polarization by absorption occurs when light is incident on a material which absorbs light which oscillates perpendicular to a transmission axis. The light which goes through the polarizer is polarized in the direction of the transmission axis.

Polarization by reflection Any reflected light is partially polarized to an axis parallel to the reflection interface. However, at a particular angle of incidence, called the polarization angle θ_p , the reflected light is totally polarized. We will discuss this in Course Guide 38.

Polarization by scattering Light can be absorbed by a material, then re-radiated. This is called scattering. Some of the scattered light travels in a direction perpendicular to the incident direction. If the incident light is polarized, the reradiated light is polarized in the same direction. If the incident light is unpolarized, the reradiated light which is perpendicular to the incident light has two directions along which it is perfectly polarized. Air molecules absorb and re-radiate blue light better than red light, which has interesting effects as we will see.

Polarization by birefringence Some materials will split a single beam of incoming light into two beams travelling at different speeds with mutually perpendicular polarizations.

37.5.3 Circular Polarization

When I looked polarizers up on Google, most of the hits were for circular polarizers. If you take light polarized in the \hat{x} direction and add to it light polarizer in the \hat{y} direction but 90° out of phase you produce circularly polarized light. In circularly polarized light, the electric vector traces out a circle around the propagation direction with the same frequency as the light.

Chapter 38

Light

38.1 Light and Matter

38.1.1 Index of Refraction

Visible light or any light is an electromagnetic wave, a wave made of crossed electric and magnetic fields, with velocity $c = 1/\sqrt{\epsilon_0\mu_0}$. When an electric field is applied to a material, the field is reduced by a factor of the dielectric constant κ . The field of a point charge in vacuum is $q/4\pi\epsilon_0r^2$ and the field in a material is $q/4\pi\kappa\epsilon_0r^2$. Since an electric field can be found by summing the fields of point charges, we can account for the effect of the material by replacing ϵ_0 with $\kappa\epsilon_0$. Likewise a magnetic field is found by summing the Biot-Savart law over the currents. The Biot-Savart law in vacuum is $|B| = \frac{\mu_0}{4\pi}I \sin\theta/r^2$. In a material the magnetic field is increased by a factor of K_m , the relative permeability to $|B| = \frac{K_m\mu_0}{4\pi}I \sin\theta/r^2$, so we can account for the effect of the magnetic response of a material by replacing μ_0 with $K_m\mu_0$.

Speed of Light in Material: The speed of light in a material, c_{matter} with dielectric constant κ and relative magnetic permeability K_m is

$$c_{matter} = \frac{1}{\sqrt{\kappa\epsilon_0K_m\mu_0}}$$

The magnetic permeability can be very slightly less than 1 but is usually bigger than 1. The dielectric constant is always greater than 1. The product κK_m is always greater than one, so the speed of light in a material is less than the speed of light in vacuum.

Light Slows Down in a Material: The speed of light in a material is lower than the speed of light in vacuum.

The amount light slows down in the material is the only property of the material we need to do optics. It is convenient to report the amount light slows as the ratio of the speed of light in a vacuum to the speed of light in a material. This ratio is given the name the *index of refraction* of the material and is given the symbol n .

Speed of Light in a Material: When light travels in a material, its speed (c_n) is *less* than the speed of light in a vacuum. The ratio of these speeds is called the index of refraction (n)

$$n \equiv \frac{c}{c_n} = \sqrt{\kappa K_m}$$

Sizes of the Index of Refraction: The index of refraction has no units since it is a ratio of velocities. The index of refraction in a vacuum is defined to be 1. The index of refraction of air is very close to 1. Water has an index of refraction of $4/3 = 1.33$.

The table below lists the index of refraction for some common materials at a few wavelengths.

Material	Index at 1000nm	Index at 550nm	Index at 365nm
Fused Silica (SiO ₂)	1.450	1.460	1.474
Flint Glass	1.586	1.607	1.646
Crown Glass	1.501	1.513	1.532
Water	1.393	1.333	1.532
Gallium Arsenide	3.492	4.333	3.601
Sodium Chloride (Salt)	1.532	1.552	1.650

Notice, the index of refraction is slightly different for different wavelengths, so the index of refraction is a function of wavelength $n(\lambda)$. This means the speed of light changes with wavelength. The range of wavelengths listed is a small piece of the electromagnetic spectrum, so the speed of light in a material for a radio wave might be quite different than the speed of light for visible light.

Dispersion: The index of refraction changes with frequency.

Dispersion is responsible for the rainbow of light produced by a prism.

The index of refraction changes with frequency because the dielectric constant and relative permeability change with frequency. The dielectric constants and relative permeabilities we have been using are static, measured at zero frequency. The static dielectric constant and static relative permeability cannot reliably be used to predict the speed of light in the material, you have to use the constants measured at the frequency of the light.

38.1.2 Wave Properties of Light in Matter

A light wave in a material is still a light wave, but with lower velocity, and it still obeys the relationship between the frequency, wavelength, and velocity of a wave:

Frequency Wavelength Relationship: The frequency, f , is related to the wavelength of light, λ , by

$$c_n = \lambda f$$

where c_n is the velocity of light in the material in which the light is travelling. Note this is the same relationship for any wave, $v_{wave} = \lambda f$.

As light travels between a vacuum and some material the velocity changes, but the frequency does not, and therefore the wavelength changes.

Frequency Doesn't Change: The frequency of light does not change as it passes through an interface into another material.

Wavelength of Light in a Material : A consequence of the reduced speed is that the wavelength of the light in the material, λ_n is reduced from its wavelength in a vacuum, λ

$$\lambda_n = \frac{\lambda}{n}$$

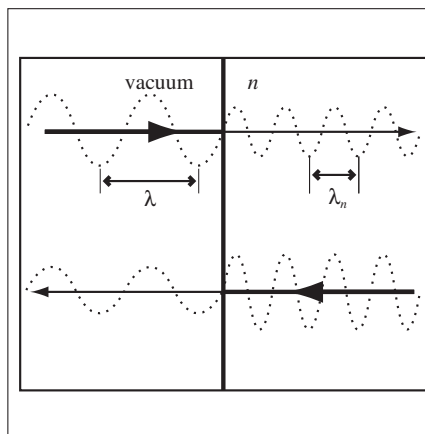

Example 38.1 Speed of Light in Materials

Problem: A 500nm laser is incident on a sheet of Lucite(TM) which has index of refraction $n_{Lucite} = 1.5$.

- (a) What is the speed of the laser light in air?
 (b) What is the wavelength of the laser light in air?
 (c) What is the frequency of the light in air?
 (d) What is the speed of the laser light in the Lucite(TM)?
 (e) What is the frequency of the light in Lucite(TM)?
 (f) What is the wavelength of the light in Lucite(TM)?

Solution to Part(a)

The speed of light in air is approximately the speed of light in a vacuum, $c_{air} \approx c = 3 \times 10^8 \frac{\text{m}}{\text{s}}$.

Solution to Part(b)

The wavelength is given in the problem, you just had to be able to correctly interpret the phrase “a 500nm laser”. $\lambda_{air} = 500\text{nm}$.

Solution to Part(c)

The frequency, f , of the laser light is found using $c = \lambda f$.

$$f_{air} = \frac{c_{air}}{\lambda_{air}} = \frac{3 \times 10^8 \frac{\text{m}}{\text{s}}}{5 \times 10^{-7} \text{m}} = 6 \times 10^{14} \text{s}^{-1}$$

Solution to Part(d)

Light moves slower in a material.

$$c_{Lucite} = \frac{c}{n_{Lucite}} = \frac{3 \times 10^8 \frac{\text{m}}{\text{s}}}{1.5} = 2 \times 10^8 \frac{\text{m}}{\text{s}}$$

Solution to Part(e)

The frequency of the light does not change when it enters a material, $f_{Lucite} = f_{air} = 6 \times 10^{14} \text{s}^{-1}$.

Solution to Part(f)

The wavelength of the laser light in the Lucite(TM) can be found using $c = \lambda f$,

$$\lambda_{Lucite} = \frac{c_{Lucite}}{f_{Lucite}} = \frac{2 \times 10^8 \frac{\text{m}}{\text{s}}}{6 \times 10^{14} \text{s}^{-1}} = 333\text{nm}$$

or

$$\lambda_{Lucite} = \frac{\lambda}{n_{Lucite}} = \frac{5 \times 10^{-7} \text{m}}{1.5} = 333\text{nm}$$

38.2 Reflection at a Plane Interface

38.2.1 Light Rays

A light wave, if it interacts with objects of a size comparable to its wavelength, will show all the complicated interference effects one sees with water waves on a pond. Visible light has a wavelength from 350nm to 700nm. The wavelength of light is most conveniently measured in nanometers(nm), where $1\text{nm} = 1 \times 10^{-9}\text{m}$. Since the wavelength of visible light is so much smaller than the size of the lenses, mirrors, and window panes

that we will consider over the next few chapters, the wave character of light is hidden and light can be taken to be a geometric ray travelling in a straight line.

When light strikes a surface, the electric and magnetic components are altered in the material as described earlier. All of Maxwell's equations must be satisfied at the surface, so Gauss' law must be satisfied for a pillbox enclosing the surface and Ampere's law must apply to an Amperian path encircling the surface. To satisfy all of Maxwell's equation, a reflected wave that bounces off the surface and a refracted wave that enters the material, but travels at a different angle are required. All three, the incident, the reflected, and the refracted ray have the same frequency.

38.2.2 Reflection at Plane Interfaces

If a light ray strikes a plane surface, some of the light bounces off the surface, is reflected, and some of the light goes through the surface and is transmitted. For a smooth surface, the reflected light makes the same angle with the surface normal as the incoming light.

Law of Reflection: Consider light that is incident on a surface/interface at a certain angle (θ_i). The reflected light leaves the surface/interface at an angle (θ_r) related to the incident angle, (θ_i), by the law of reflection,

$$\theta_i = \theta_r$$

That is to say, light reflects from a point on the interface at the same angle it arrived.

Angles and the Normal to the Interface: An interface is the boundary between two materials. At any point on the interface, a line can be imagined which is perpendicular (normal) to the interface. All angles in geometric optics are measured with respect to the normal.

The incident and reflected rays are drawn to the right. When you look into a mirror, the light appears to come from the line traced back from the reflected ray. This direction is drawn as a dashed line. All angles are measured from the normal.

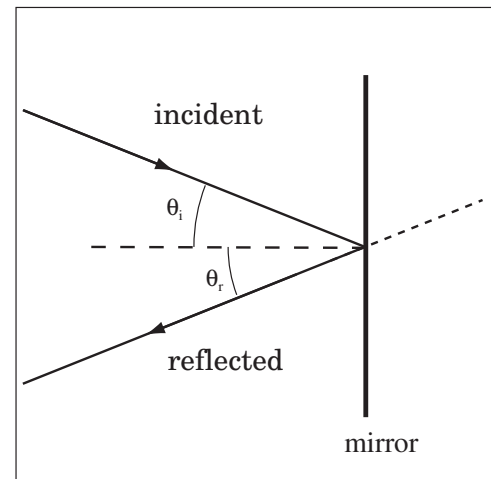

38.3 Snell's Law - Refraction at Plane Interfaces

38.3.1 Refraction at Planes Interfaces - Snell's Law

When a light ray strikes an interface between two transparent materials at an angle, some of the light is reflected, but the rest goes through the interface, and is bent either toward or away from the surface normal. The bending of the light ray as it passes through the interface is called *refraction*. The amount the light ray is refracted is governed by Snell's law:

Law of Refraction (Snell's Law): If the light travels from a material with index of refraction, n_i and is transmitted across an interface into another material with index of refraction, n_t , and the angle of incidence at the interface between the material is, θ_i , to the normal then the angle of transmission θ_t is related by Snell's Law

$$n_i \sin \theta_i = n_t \sin \theta_t$$

If you play with Snell's law a bit, you find that as light travels from a lower index of refraction to a higher index of refraction, the light is bent closer to the surface normal. As light travels from a higher to lower index of refraction, the light bends farther away from the surface normal. Both cases are drawn below.

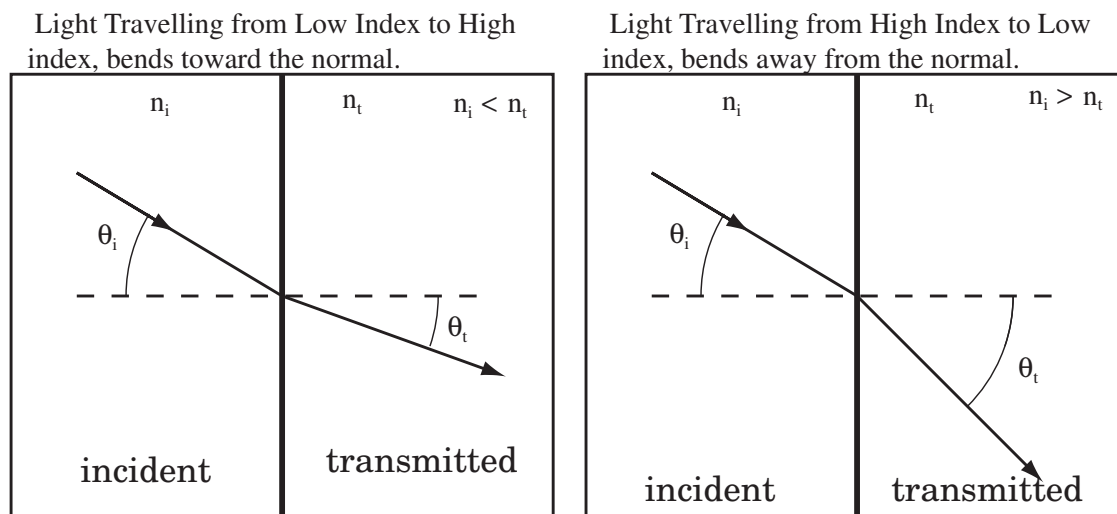

38.3.2 Critical Angle

As light travels from a material with high index of refraction to a material with low index of refraction, it bends away from the surface normal. If the light is bent to an angle of 90° with the surface normal, it cannot escape the material. It is said to undergo *total internal reflection*. The angle where this first occurs is called the critical angle and depends on the index of refraction of the two materials.

Total Internal Reflection : When light goes from a high index to a lower index material, it is possible that the transmitted light will not leave the interface boundary. The minimum incident angle for which this occurs is called the critical angle. The critical angle is reached when $\theta_t = 90^\circ$. This means Snell's Law becomes $n_i \sin \theta_c = n_t$ and solving for the angle gives

$$\theta_c = \arcsin \frac{n_t}{n_i}$$

The light will be totally internally reflected for $\theta_i \geq \theta_c$.

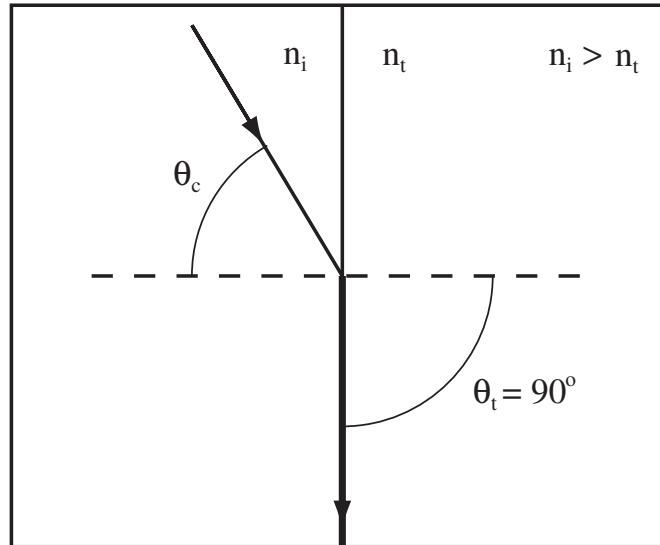

Example 38.2 Critical Angle

Problem: A material has a critical angle of 47° when immersed in water $n_{water} = 4/3$. What is the speed of light in this material?

Select One of the Following:

- (a) $3 \times 10^8 \frac{\text{m}}{\text{s}}$ (b) $2.1 \times 10^8 \frac{\text{m}}{\text{s}}$ (c-Answer) $1.6 \times 10^8 \frac{\text{m}}{\text{s}}$ (d) Cannot be determined from the information given. (e) Toby

Solution

Let the index of refraction of the material we're seeking be n_1 and the water be n_2 . The critical angle is the angle of incidence required to produce an angle of refraction of 90° .

$$n_1 \sin \theta_c = n_2 \sin 90^\circ,$$

with $\theta_c = 47^\circ$ and $n_2 = 4/3$. Solving for n_1 gives

$$n_1 = \frac{4/3}{\sin 47^\circ} = 1.82$$

The speed of light in the material, c_1 , is then

$$c_1 = \frac{c}{n_1} = \frac{3 \times 10^8 \frac{\text{m}}{\text{s}}}{1.82} = 1.6 \times 10^8 \frac{\text{m}}{\text{s}}.$$

Example 38.3 Refraction at an Interface

Problem: In a certain material, light has a speed of $1.5 \times 10^8 \frac{\text{m}}{\text{s}}$ and a wavelength of 320nm. The light is originally in this material and impinges on the interface with another material in which the speed of light is $2.5 \times 10^8 \frac{\text{m}}{\text{s}}$.

- What is the index of refraction, n_1 , of the first material?
- What is the index of refraction, n_2 , of the second material?
- What is the wavelength of the light in air?
- What is the wavelength of the light in the second material?
- Is it possible for the light to undergo total internal reflection as it travels from the 1st to the 2nd material?
- If the angle of incidence is 55° , does the light undergo total internal reflection?
- If the angle of incidence in the first material is 20° , what is the angle of refraction in the second material?

Solution to Part(a)

Let the first material in the problem be material 1 with light speed $c_1 = 1.5 \times 10^8 \frac{\text{m}}{\text{s}}$ and the second material be material 2 with light speed $c_2 = 2.5 \times 10^8 \frac{\text{m}}{\text{s}}$. The index of refraction of material 1 is by definition,

$$n_1 = \frac{c}{c_1} = \frac{3 \times 10^8 \frac{\text{m}}{\text{s}}}{1.5 \times 10^8 \frac{\text{m}}{\text{s}}} = 2$$

Solution to Part(b)

The index of refraction of material 2 is by definition

$$n_2 = \frac{c}{c_2} = \frac{3 \times 10^8 \frac{\text{m}}{\text{s}}}{2.5 \times 10^8 \frac{\text{m}}{\text{s}}} = 1.2$$

Solution to Part(c)

The wavelength in a material is reduced by a factor of the index of refraction from the wavelength in a vacuum. If λ is the wavelength in a vacuum, then $\lambda_1 = \lambda/n_1$. Solving for

$$\lambda = \lambda_1 n_1 = (320\text{nm})(2) = 640\text{nm} = 640 \times 10^{-9}\text{m}$$

Solution to Part(d)

The wavelength in a material is reduced by a factor of the index of refraction of the material, $\lambda_2 = \lambda/n_2 = 533.3 \times 10^{-9}\text{m}$.

Solution to Part(e)

Yes, since the first index of refraction is higher than the second, light travelling from a higher index of refraction to a lower index can undergo total internal reflection.

Solution to Part(f)

Applying Snell's Law with a transmitted angle of 90° gives

$$n_1 \sin \theta_c = n_2 \sin 90^\circ$$

Solve for θ_c ,

$$\theta_c = \sin^{-1} \left(\frac{n_2}{n_1} \right) = 36.9^\circ$$

Since $55^\circ > 36.9^\circ$ the light will be totally internally reflected.

Solution to Part(g)

Applying Snell's Law, $n_1 \sin \theta_1 = n_2 \sin \theta_t$, with $\theta_1 = 20^\circ$.

$$\sin \theta_t = \frac{n_1 \sin \theta_1}{n_2},$$

and thus the light is reflected at an angle of

$$\theta_t = \sin^{-1} \left(\frac{n_1 \sin \theta_1}{n_2} \right) = 34.75^\circ$$

38.4 Transmission and Reflection

38.4.1 Intensity of Transmission and Reflection

As a light ray strikes an interface, some of the light is reflected and some is transmitted. To express how much light is reflected or transmitted, we need to be able to tell how much light we have. Light carries energy from place to place, the more energy, the more light. The amount of light in a light ray is measured by its *intensity*, the amount of energy crossing a unit area per unit time, or the power per unit area. Let's recall the definition of intensity.

Definition of Intensity: The intensity, $I(t)$, of a wave is the energy, $U(t)$, crossing a unit area, A , per unit time. This is the same as power, $P(t)$, per unit area,

$$I(t) = \frac{U(t)}{At} = \frac{P(t)}{A}$$

The intensity of the reflected and transmitted light rays can be calculated from Maxwell's equations. The reflected intensity changes in a complicated manner with the angle of incidence. The reflected intensity also depends on the direction of the electric component of the wave. The amount of light reflected is different if the electric component lies in the plane formed by the direction of propagation and the surface normal or is perpendicular to the plane.

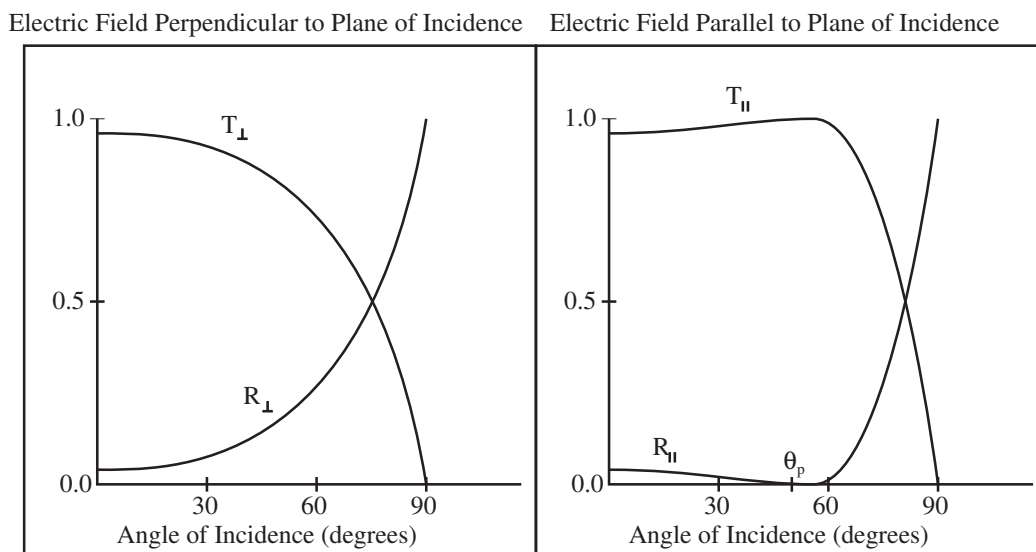

There are two special cases where the same result is obtained for any direction of the electric component of the field, normal incidence where the angle of incidence is zero and grazing incidence where the angle of incidence is 90° . If the light ray strikes a surface at normal incidence, perpendicular to the surface, the reflected intensity I_r has a simple relation to the indices of refraction of the two materials. Since energy is conserved, the transmitted intensity, I_t , is the difference between the incident intensity and the reflected intensity. We will only deal with normal incidence, because the expression becomes much more complicated away from normal incidence.

Intensity of Reflected Light : In the special case that the incident light strikes the interface at right angles (normal incidence), the intensity of the reflected light, I_r , is a fraction of the intensity of the incident light, I_i .

$$I_r = \left(\frac{n_i - n_t}{n_i + n_t} \right)^2 I_i$$

Energy is Conserved: If there is no absorption, then the reflected intensity and the transmitted intensity must add up to the total intensity.

$$I_i = I_r + I_t$$

Grazing Incidence: If the angle of incidence is 90° , that is if the light just grazes the surface, then all the light is reflected and no light is transmitted.

Example 38.4 Transmission through Plane Sandwich

Problem: Sunlight of intensity $1000 \frac{\text{W}}{\text{m}^2}$ is normally incident on a sheet of Lucite with $n_{\text{Lucite}} = 1.5$, which is stacked on top of a sheet of plain old glass with $n_{\text{glass}} = 1.4$. To the first order, which means we ignore the light which undergoes multiple reflections, compute the intensity of the transmitted light.

Solution

Definitions

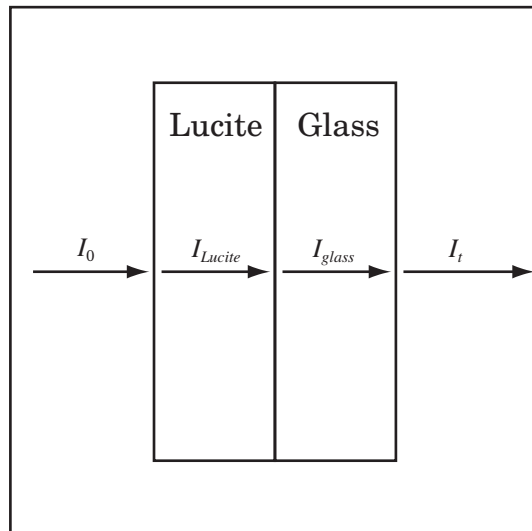

$n_{\text{air}} = 1 \equiv$ Index of Refraction of Air
 $n_{\text{Lucite}} = 1.5 \equiv$ Index of Refraction of Lucite(TM)
 $n_{\text{glass}} = 1.4 \equiv$ Index of Refraction of Glass
 $I_t \equiv$ Transmitted Intensity
 $I_0 = 1000 \text{W}/\text{m}^2 \equiv$ Incident Intensity
 $I_{\text{Lucite}} \equiv$ Intensity in the Lucite
 $I_{\text{glass}} \equiv$ Intensity in the Glass

Strategy: Apply the formula for the reflected intensity of normally incident light at each interface.

(a) Compute Transmitted Intensity at Air-Lucite Interface: The reflected intensity at the first interface is

$$I_{\text{reflected}} = \left(\frac{n_{\text{air}} - n_{\text{Lucite}}}{n_{\text{air}} + n_{\text{Lucite}}} \right)^2 I_0$$

$$I_{\text{reflected}} = \left(\frac{1 - 1.5}{1 + 1.5} \right)^2 I_0 = 0.04 I_0$$

Since energy is conserved, the transmitted intensity at the Air-Lucite interface, I_{Lucite} , is

$$I_{Lucite} = I_0 - I_{reflected} = 0.96I_0$$

(b) Compute the Transmitted Intensity at the Lucite-Glass Interface: The reflected intensity at the second interface is

$$I_{reflected,glass} = \left(\frac{n_{Lucite} - n_{glass}}{n_{Lucite} + n_{glass}} \right)^2 I_{Lucite}$$

$$I_{reflected,glass} = \left(\frac{1.5 - 1.4}{1.4 + 1.5} \right)^2 I_{Lucite} = 0.001I_{Lucite}$$

So the transmitted intensity through the Lucite-Glass interface,

$$I_{glass} = I_{Lucite} - I_{reflected,glass} = 0.999I_{Lucite}.$$

(c) Compute the Transmitted Intensity at the Glass-Air Interface: The reflected intensity at the third interface is

$$I_{reflected,air} = \left(\frac{n_{glass} - n_{air}}{n_{glass} + n_{air}} \right)^2 I_{glass}$$

$$I_{reflected,air} = \left(\frac{1.4 - 1}{1.4 + 1} \right)^2 I_{glass} = 0.028I_{glass}$$

Therefore, the transmitted intensity is

$$I_t = I_{glass} - I_{reflected,air} = 0.972I_{glass}.$$

(d) Multiply It All Out: Combine the results of the three previous sections

$$I_t = (0.96)(0.999)(0.972)I_0 = (0.932)(1000 \frac{W}{m^2}) = 932 \frac{W}{m^2}$$

38.4.2 Polarization by Reflection - Brewster's Law

If you examine the transmission and reflection curves for light where the electric field is the plane of incidence above, there is an angle of incidence, θ_p , where all the light is transmitted and none is reflected. All reflected light at this angle has its electric component perpendicular to the plane of incidence. The angle occurs when the refracted and reflected light are 90° apart. This means that the reflected light is polarized with a direction of polarization perpendicular to the plane of incidence.

Brewster's Law: The polarization angle, θ_p , for light incident from a material with a certain index of refraction, n_i , being reflected from another material with index of refraction, n_t , is given by Brewster's Law

$$\theta_p = \arctan \left(\frac{n_t}{n_i} \right)$$

Light polarized by reflection has its electric field perpendicular to the plane of incidence.

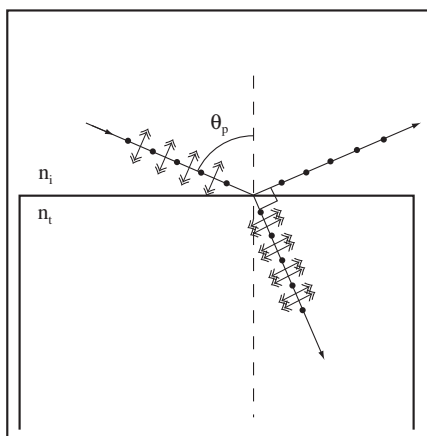

Example 38.5 Brewster Angle for Water

Problem: At what angle to the normal must light be incident on a calm lake so that the reflected light is polarized?

Solution

The light goes from $n_i = 1$ to $n_t = 1.33$, so the angle of polarization, θ_p , is given by Brewster's law,

$$\theta_p = \arctan\left(\frac{n_t}{n_i}\right) = \arctan\left(\frac{1.33}{1}\right) = 53^\circ$$

Example 38.6 Refraction from a Plane Surface

Problem: In a certain material, light has a speed of $1.5 \times 10^8 \frac{\text{m}}{\text{s}}$. When light from air is incident on this interface (which is in the x - y plane), the angle of transmission is 26° .

- What is the refractive index of this material?
- What is the angle of incidence?
- What is Brewster's angle for this situation?
- What is the angle of reflection?
- Is the reflected light fully polarized, mostly polarized, or very unpolarized? If fully or mostly polarized, in what direction is the polarization?

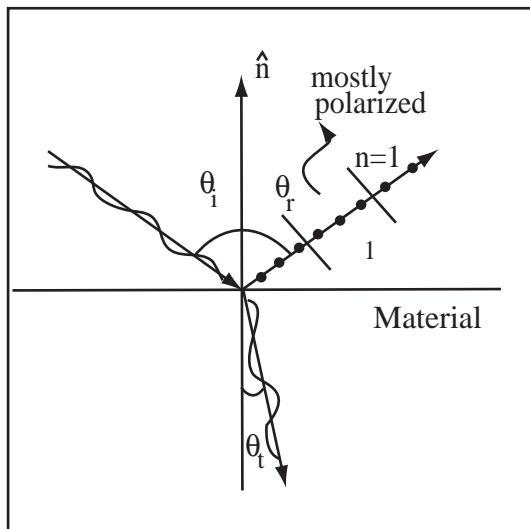
Definitions

$$v_n = 1.5 \times 10^8 \frac{\text{m}}{\text{s}} \equiv \text{Velocity of Light in Material}$$

$$\theta_i \equiv \text{Incident Angle}$$

$$\theta_t \equiv \text{Transmitted Angle}$$

$$\theta_r \equiv \text{Reflected Angle}$$

$$\theta_p \equiv \text{Brewster's Angle}$$

$$n \equiv \text{Index of Refraction of Material}$$

Strategy: Use Snell's Law to compute the angle of refraction, and Brewster's Law the angle of polarization.

Solution to Part (a)

Compute the Index of Refraction: The Index of Refraction is the ratio of the velocity of light in the material to the velocity of light in vacuum

$$n = \frac{c}{v_n} = \frac{3 \times 10^8 \frac{\text{m}}{\text{s}}}{1.5 \times 10^8 \frac{\text{m}}{\text{s}}} = 2$$

Solution to Part (b)

Compute Angle of Incidence: Use Snell's Law to relate the angle of incidence to the angle of refraction (transmission).

$$n_{air} \sin \theta_i = n \sin \theta_t$$

Using $n_{air} = 1$ and $n = 2$, gives

$$\sin \theta_i = 2 \sin 26^\circ$$

Solving for θ_i and

$$\theta_i = \arcsin(2 \sin 26^\circ) = 61^\circ$$

Solution to Part (c)

Compute Brewster's Angle: Brewster's Angle is given by $\tan \theta_p = \frac{n}{n_{air}} = n$, so

$$\theta_p = \arctan(n) = 63^\circ.$$

Solution to Part (d)

Compute Angle of Reflection: The Angle of Reflection equals the Angle of Incidence

$$\theta_r = \theta_i = 61^\circ$$

Solution to Part (e)

The reflected beam is close to Brewster's Angle, so the reflected light is almost fully polarized. The direction of polarization is perpendicular to the plane of incidence.

Chapter 39

Geometric Optics

Light is an electromagnetic wave, but also a flux of photons. To learn more about the wave nature of light take UPIII. To learn more about photons, take Modern Physics. We can understand the behavior of systems composed of mirrors and lenses by modelling light as a ray. The study of light in situations where it behaves as a ray is called geometric optics. Geometric optics is a good approximation as long as the wavelength of light is small compared to the size of optical system. Visible light has a wavelength on the order of 500nm, therefore systems composed of lenses and mirrors are well approximated by geometric optics. Chromatic aberrations, polarization, and interference effects cannot be explained by the geometric optics model. For these, we need a model of light that recognizes its wave nature, that is to say, wave (physical) optics. For some effects in nature, even the wave model is not adequate and we must take into account the corpuscular nature of light and then we have a model called quantum optics.

39.1 Image Formation

39.1.1 What is an Image?

When light shines on an object, the light appears to scatter in all directions (diffuse reflection). This is because if one looks closely enough at any surface, the surface appears rough. Light always bounces off so that the angle of incidence equals the angle of reflection, measured with respect to the normal to the surface. If the surface is REALLY smooth, the normal for all points on the surface is in the same direction and light reflects in a single direction from the surface(specular reflection). The surface is shiny.

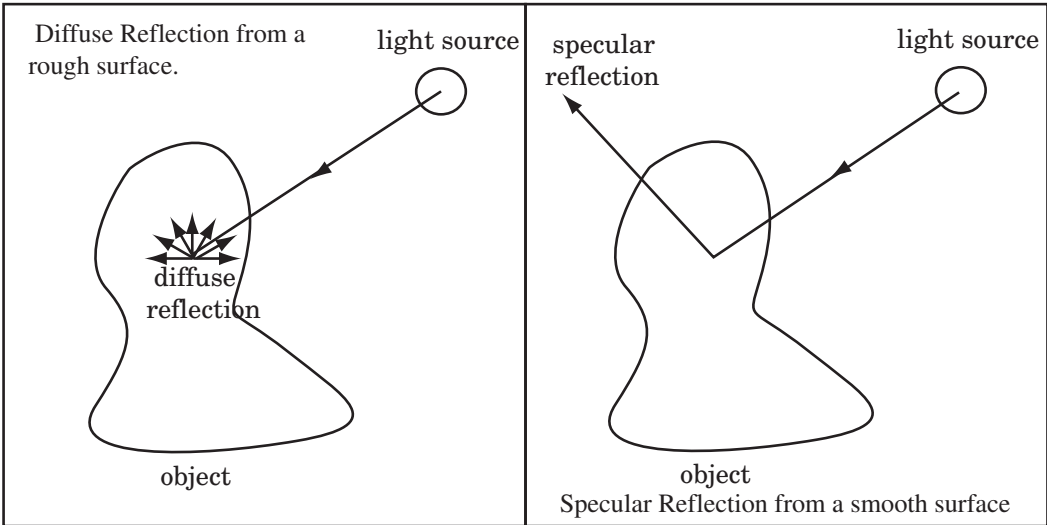

After bouncing off the object, the light will travel in straight lines called light rays. So if we place a screen

somewhere in the path of these light rays without using some optical element to sort out the various rays, each point on the screen will receive light rays from all points on the object and all that we'll see is a general impression of the color of the object.

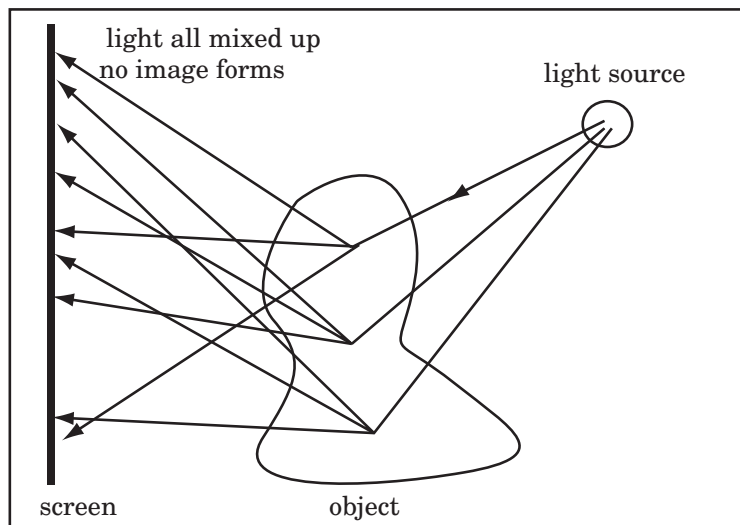

If we place an optical system between the screen and the object—we can form an *image* on the screen, where all light rays from the same point on the object strike the same point on the screen. When the screen is placed where the light rays from a single point converge (where a sharp image is formed), we say that the image is focused. The dashed lines drawn in the optical system do not represent the light rays. They allow you to associate incoming and outgoing rays. The path through the optical system may be very complex.

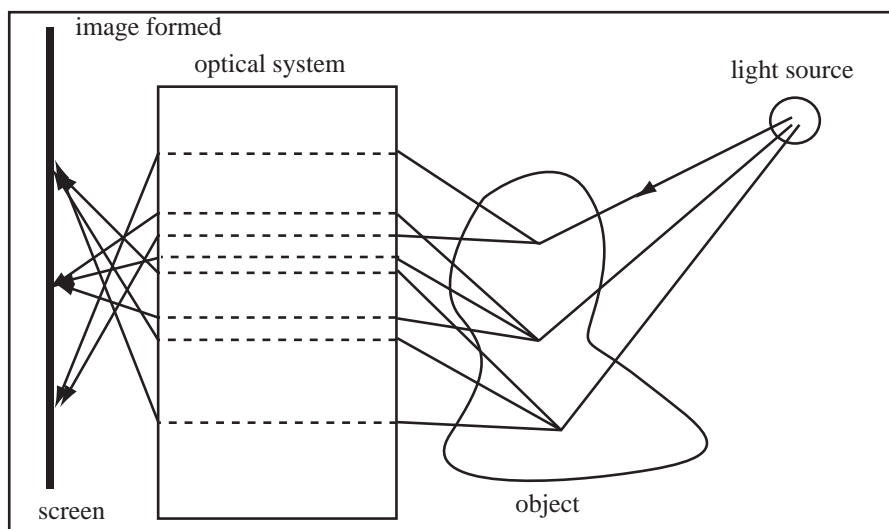

The image will be fuzzy if the screen is moved closer to or farther away from the optical system, since the light rays do not meet at the same point on the screen. In this case, the image is said to be out of focus.

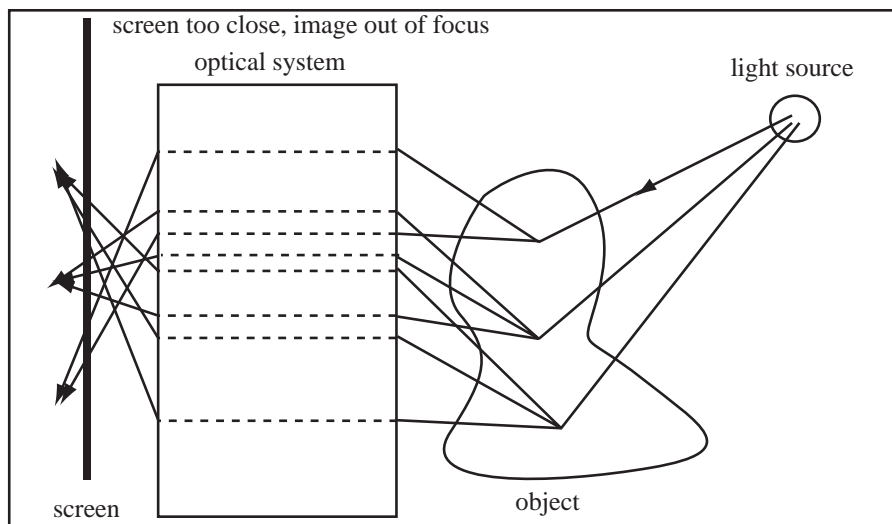

Definition of Image: An image is a surface in space where all light rays coming from the same point on an object intersect.

The light rays continue in a straight line after passing through the surface where the image forms. They may eventually be detected by an optical detector like the human eye. The detector sees the rays originate at the last point they all crossed, at the image. The detector only measures the direction the light rays are travelling when they encounter the detector, their apparent direction. This direction may be very different than the direction they were travelling when they left the object.

Apparent Direction: No matter what (possibly convoluted) path that light may take from a source to a detector, the **apparent source direction** is the direction from which the light enters the detector. The line of sight is along the apparent source direction (the dotted line in the figure to the right).

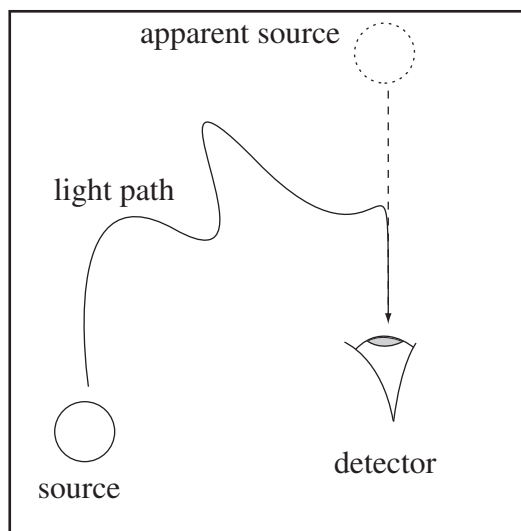

39.1.2 Describing Images

An optical system takes light reflected from an object and brings light rays from the same point on the object to the same point on the image. Images are only interesting when something detects them. The most common image detector is the human eye. We will use the following symbols to represent the object, the location of the image, and the placement of the detector.

Representing an Object: An object is represented by a solid arrow as shown to the right.

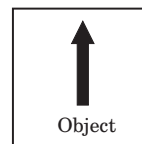

Representing an Image: An image will be represented by a hollow arrow as shown to the right.

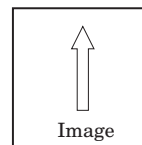

Representing an Optical Detector: The human eye or any optical detector does not see an object, it sees the light rays coming from the object. We will draw an optical detector as a cartoon of an eye as shown to the right.

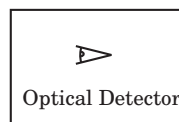

The image formed by an optical system is described by three features: whether it is bigger or smaller than the object, whether it is right side up or upside down compared to the object, and whether it is formed of physical light rays or the apparent direction of light rays. The first two of these features are captured in a single number, the magnification, m . The magnification is positive if the image has the same orientation as the object and negative if the image is upside down. The magnitude of the magnification is the ratio of the image height to the object height. Therefore, if the image is twice as large as the object and right side up, then the magnification is 2. If the image is one third the height of the object and upside down, then the magnification is $-\frac{1}{3}$.

Magnification and Inversion : If the image is a different size than the object, then it is magnified (reduced or enlarged, depending on the relative size). If the image is oriented in the same direction as the object, then the image is upright. If the image is oriented in the opposite direction, it is inverted. This classification can be represented by a number, m , called the magnification of the image. The table below consolidates the meanings of various values of Magnification for the black arrow as the original object (images are in outline)

Object	Image ($m=1$)	$m=0.5$	$m=-0.5$	$m=-1.5$
	Not Magnified	Reduced Upright	Reduced Inverted	Enlarged Inverted

39.1.3 Real and Virtual Images

The last feature of an image is whether the image is real or virtual. A real image is formed at the location where light rays from the object actually cross. If a screen were placed at the location of a real image, the image would be projected on the screen. A virtual image is formed at the point the apparent direction of light rays cross. Since no real light rays cross there, no image would be projected on a screen placed at the location of a virtual image.

Real Image Formation : Consider light that is reflected from a single point on an object. The reflected light can take different paths to a detector. If the light paths themselves intersect, then a real image is formed at that intersection point. An example of real image formation is shown below for a concave mirror.

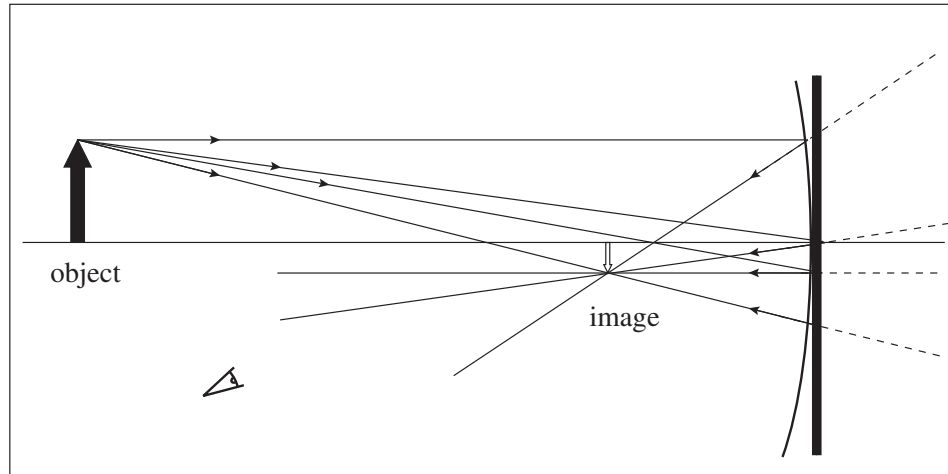

Virtual Image Formation : Consider light that is reflected from a single point on an object. The light can take different paths to a detector. If the light paths do not intersect, but the apparent source directions do, then a virtual image is formed. An example of virtual image formation is shown below for a diverging lens. In this case the light travels through the optical element and so the detector is to the right.

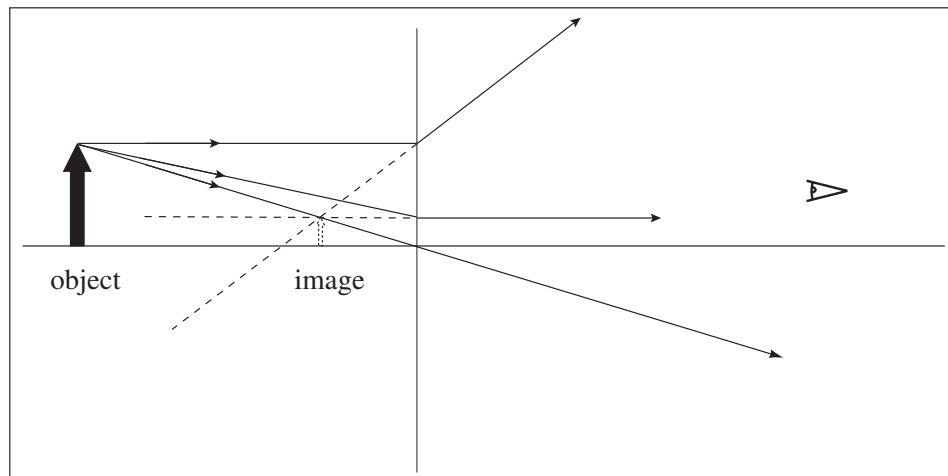

39.2 Image Formation by Flat Surfaces

39.2.1 Image Formed by a Flat Mirror

Much of our experience with image formation is with flat surfaces: mirrors, windows, ponds. An image is formed by both the refracted and the reflected ray. In either case, we have two tasks (1) Find where the image is and (2) Describe the image as real or virtual, upright or inverted, and reduced or enlarged. Our

tools are the definition of image, the law of reflection, and Snell's law. Using the definition of an image we can find the location of the image by:

Locating the Image: To locate the image, follow two light rays emerging from the same point on the object. The rays will intersect or appear to intersect at the image.

So we need to select two light rays. The ray that leaves the base of the object and strikes the mirror with normal incidence is the easiest to trace since it is reflected directly back on itself. Select a second ray that leaves the base of the object making an angle θ to the first ray. This ray will strike the mirror with angle of incidence θ and be reflected at an angle θ as drawn below. The rays leaving the mirror never intersect so a real image is not formed. The apparent direction of the outgoing rays cross behind the mirror. A virtual image is located at the point they cross. By similar triangles, the image is the same distance behind the mirror that the object is in front of the mirror.

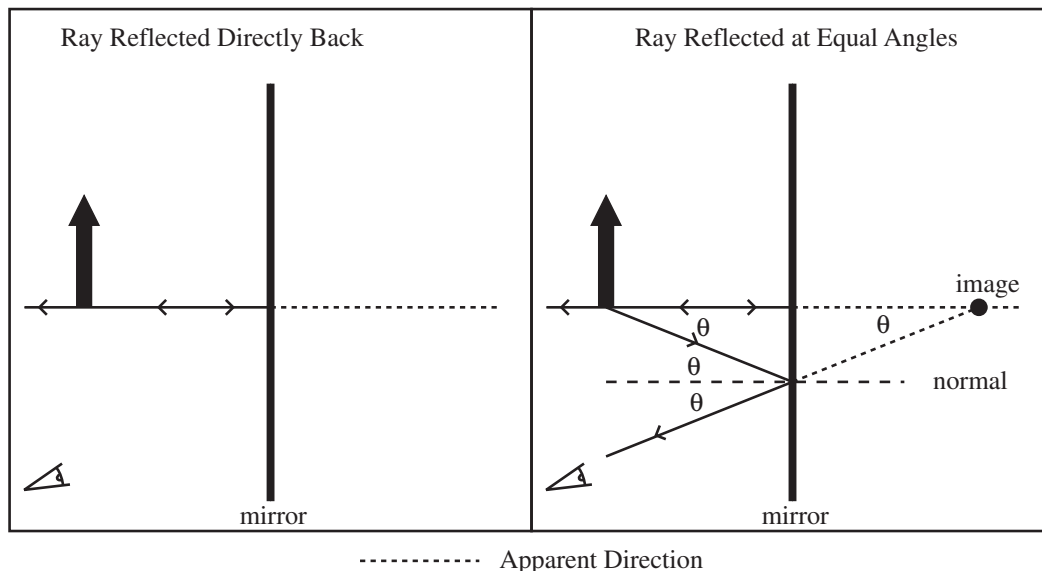

This analysis tells us nothing about the size and orientation of the image. To find this information, we have to trace rays from two separate points on the object.

Describing the Image: To find the size and orientation of the image after the location is found, trace one ray from the top of the object and one ray at the bottom. These rays will pass through the top and the bottom of the image at the image location.

We have already traced two rays from the base of the object through the system, so we know where the base of the image is. Now, trace a ray from the top of the object. The easiest ray is the ray that strikes the mirror at normal incidence. This ray is drawn to the right. The apparent direction of this ray must pass through the top of the image. I have drawn the image in. The image is the upright and the same height as the object, so the magnification is $m = 1$.

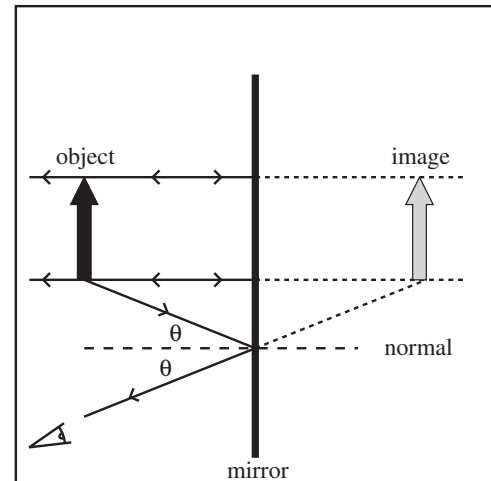
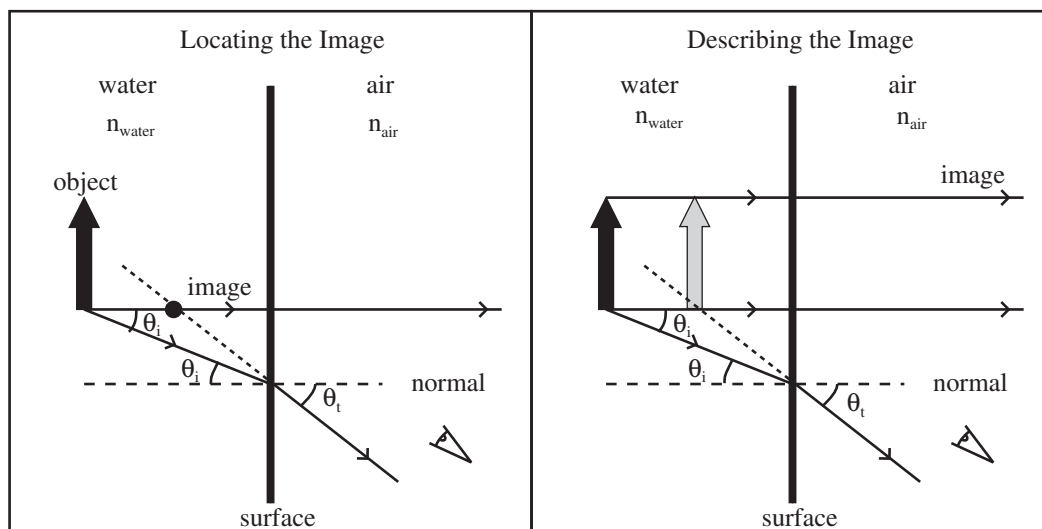

Image Formed by Flat Mirror: The image formed by a flat mirror is virtual, behind the mirror, upright and the same size as the object ($m = 1$).

39.2.2 Image Formed by Refraction at a Flat Surface

Now let's form an image by the refracted rays at a flat surface. The most common example of this is the image you observe of a fish formed by the flat surface of the side of an aquarium. We can use the same method to find the location and size of the fish image. First, trace two rays from the base of the object to find the image location. The first ray traced is a ray that strikes the surface at normal incidence. This ray passes through the surface without refraction. Next, trace a ray that intersects the surface at an angle θ_i . This ray is refracted with transmitted angle that is related to incident angle by Snell's law. Since the ray moves from higher index to lower index, the ray bends away from the normal so $\theta_t > \theta_i$ as drawn. The outgoing rays never intersect, so no real image is formed. The apparent directions of the outgoing rays intersect at the location of a virtual image as drawn. To find the size and orientation of the image, trace a ray from the top of the object. The easiest ray to trace is the ray that meets the surface at normal incidence. This ray passes through the surface without being refracted. Its apparent direction passes through the top of the image. I have drawn the image. The image is upright and of the same orientation as the object, so $m = 1$. The image appears nearer the surface than the object, which is why it is tricky to grab something underwater.



To actually solve for the image location quantitatively, we would have to solve Snell's law for θ_t , then express θ_i in terms of the object location. This is bad enough from a flat interface, but becomes intensely terrible for a curved interface. To simplify matters, we will make an assumption that is approximately true for almost any optical system of interest.

Paraxial Rays: Paraxial rays, nearly parallel rays, are rays that meet the interfaces of an optical system at sufficiently small angles that the small angle approximation is valid: $\sin \theta \approx \theta$, $\tan \theta \approx \theta$, and $\cos \theta \approx 1$. We will use this approximation from now on when analyzing optical systems.

Since most of our optical systems are not drawn to scale, most of our drawings will not look like this is a good hypothesis, but I have to get the drawing on a sheet of paper.

Assuming the rays passing through the system are paraxial, Snell's law simplifies to $n_i \theta_i = n_t \theta_t$. I have redrawn the system to the right with s as the distance the object is from the surface, s' the distance the image is from the surface, and h the height the ray intersects the interface. Since the angles are small, we can write $\tan \theta_i = h/s \approx \theta_i$ and $\tan \theta_t = h/s' \approx \theta_t$. Substituting into Snell's law gives,

$$n_i \theta_i = n_i \frac{h}{s} = n_t \theta_t = n_t \frac{h}{s'}$$

where $n_i = n_{\text{water}}$ and $n_t = n_{\text{air}}$. Solving for the image distance gives, $s' = (n_{\text{air}}/n_{\text{water}})s = 0.75s$. So for water, the fish appears to be only $\frac{3}{4}$ of the distance from the aquarium surface as it actually is. This is what makes grabbing things underwater dicey.

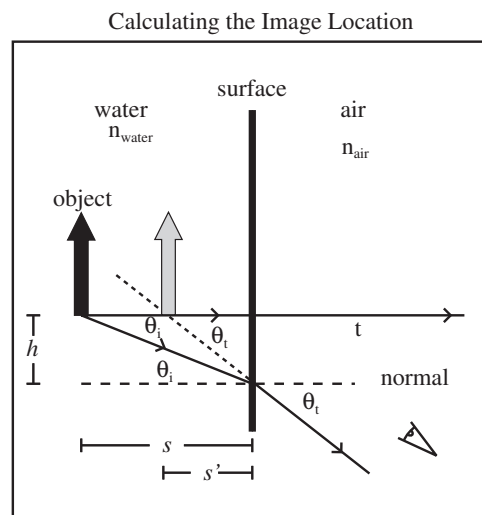

39.3 Thick Spherical Interfaces

39.3.1 Image Formation in a Curved Mirror

We can use the same methods to locate and describe the image of a curved mirror. First, we need to be able to describe how the mirror is curved. We will work with mirrors that are sections of spherical surfaces. To define the curvature of a spherical surface we simply need to know where the center of the sphere is. We will call the point at the center of the sphere the *center of curvature*, and label the point C . An object, a curved mirror, and the center of curvature is drawn below. The center of curvature is important because a line drawn from the center of curvature to the mirror is the normal to the mirror's surface, because a line drawn from the center of a sphere to the surface of the sphere is a radius of the sphere and is perpendicular to the surface of the sphere. We will let the line that intersects the base of the object and the center of the mirror be the axis of the system. The point where the axis intersects the mirror is called the vertex of the system.

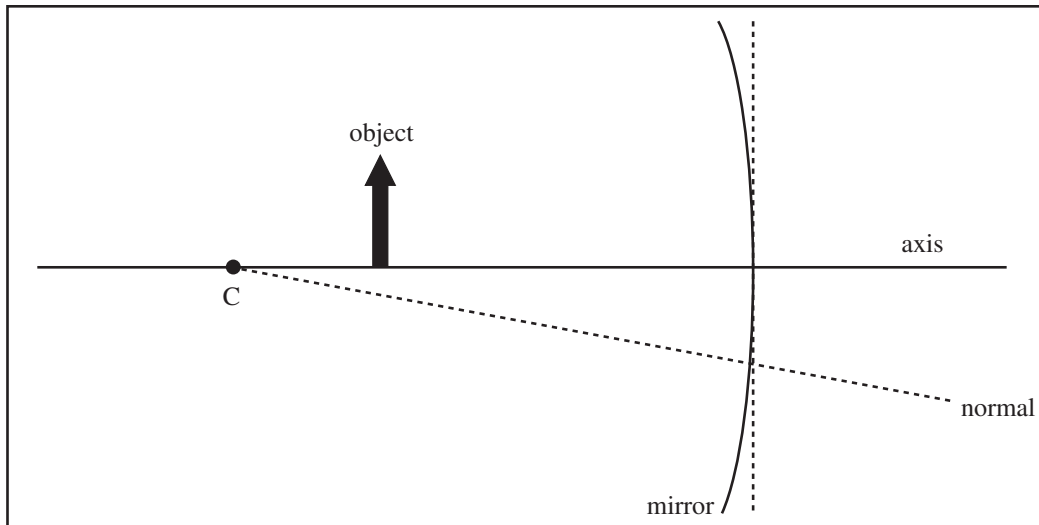

To locate the image, we take two rays from the same point on the object and see where they go. We'll use two rays from the base of the object. The ray that strikes the mirror at normal incidence bounces directly back on itself. A ray that leaves the object at an angle θ_o strikes the mirror at an angle of incidence of α . It reflects from the mirror with an angle of reflection α . This reflected ray intersects the ray with normal incidence at the image and makes an angle θ_i to the axis. The angle the normal makes with the axis, θ_c , will also be important.

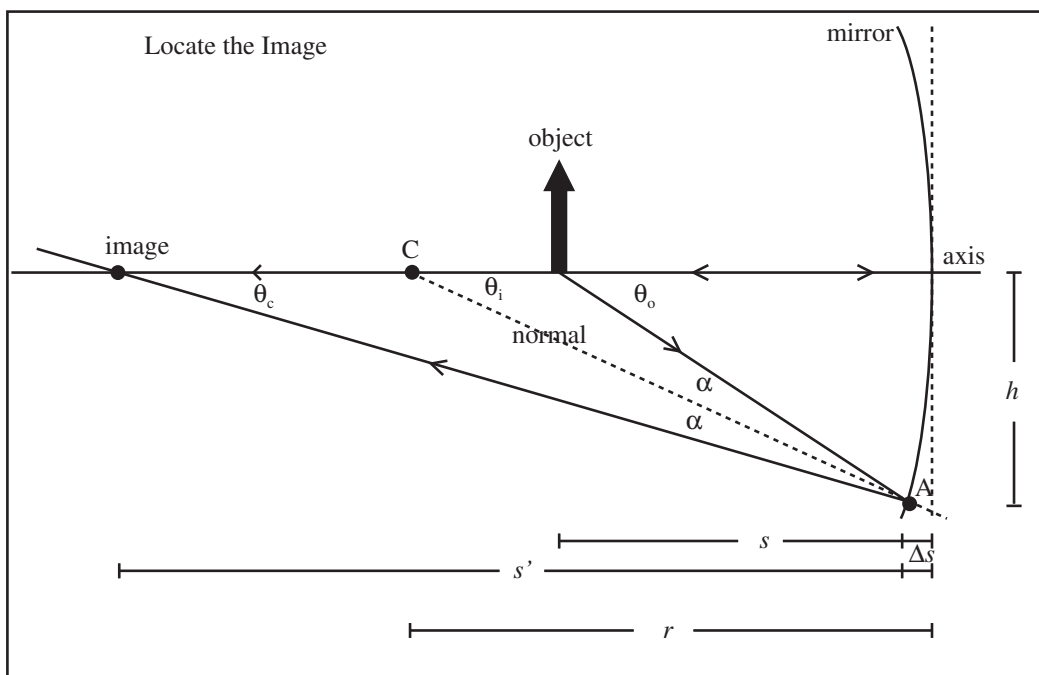

Using a little geometry and a lot of small angle approximation, we can find the mathematical location of the image. First, another approximation that will save us a lot of work. The distance Δs , the distance the curvature of the mirror moves the point the second ray intersects the surface from the vertex, will cause us no end of annoyance. Assume this distance is small compared to s and s' .

Thin Lens/Mirror Approximation - Part I: The distance the lens' or mirror's surface curves away from the vertex is small and can be ignored in all calculations.

Symbols for Optical Systems: We will use the following symbol convention. The distance the object is from the mirror or lens will be called the object distance and denoted by the symbol s . The distance the image is from the mirror or lens will be called the image distance and denoted by the symbol s' . The distance the center of curvature is from the lens or mirror will be called the radius of curvature and denoted by r .

Let point A be the point where the second ray strikes the mirror and h be the distance point A is from the axis as drawn above. Using the small angle approximation we can write

$$\tan \theta_o = \frac{h}{s} \approx \theta_o \quad \tan \theta_i = \frac{h}{s'} \approx \theta_i \quad \tan \theta_c = \frac{h}{r} \approx \theta_c$$

There must be 180° in a triangle. For the triangle (image- C - A), this means

$$\theta_i + (180^\circ - \theta_c) + \alpha = 180^\circ \quad \rightarrow \quad \theta_i + \alpha - \theta_c = 0$$

and for the triangle (C -object- A)

$$\theta_c + (180^\circ - \theta_o) + \alpha = 180^\circ \quad \rightarrow \quad \theta_c + \alpha - \theta_o = 0$$

Use these two equations to eliminate α ,

$$\theta_o + \theta_i = 2\theta_c \quad \Rightarrow \quad \frac{h}{s} + \frac{h}{s'} = 2\frac{h}{r} \quad \Rightarrow \quad \frac{1}{s} + \frac{1}{s'} = \frac{2}{r}$$

Thin Mirror Equation: The location of the image of a slightly curved mirror is found using the equation

$$\frac{1}{s} + \frac{1}{s'} = \frac{2}{r}$$

Since we have already traced the rays from the base of the object to the image, we can find the height and orientation of the image by tracing a ray from its point. The ray that travels from the point the vertex has incident angle β is reflected at equal angle β . The image is upside down, so the magnification is negative. The ratio of the height of the image to the height of the object is given by similar triangles $m = -h_i/h_o = -s'/s$.

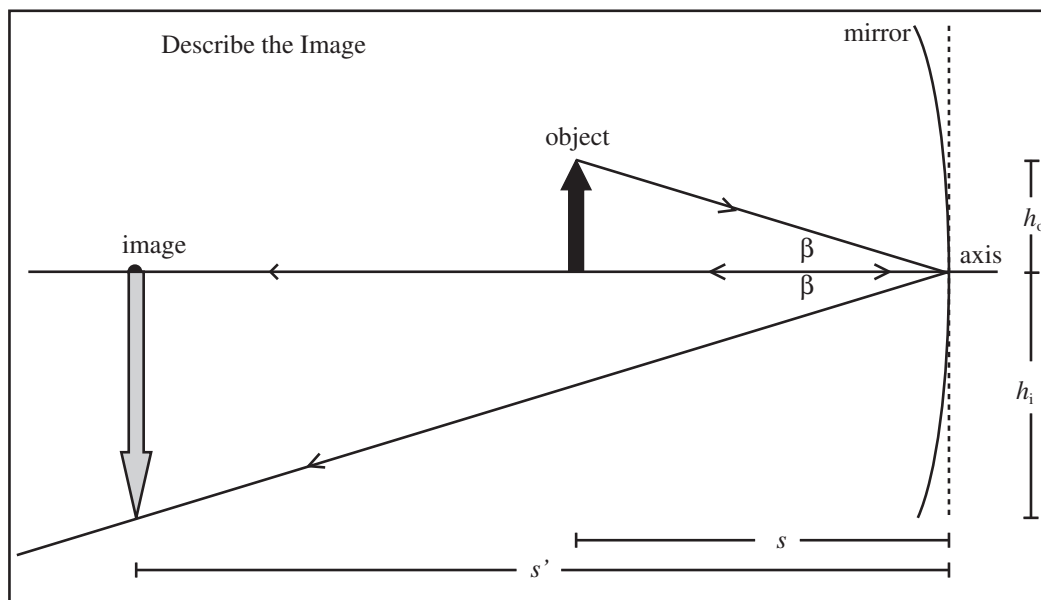

Magnification of a Thin Mirror: The magnification of a slightly curved mirror is $m = -s'/s$ where s' is the image distance and s is the object distance.

The image formed was real because light from the object actually crossed at the image. Also the image is enlarged, and inverted.

39.3.2 Image Formation by Refraction at a Curved Surface

We can also use the light refracted from a curved surface to form an image. Most images formed by refraction go through two curved surfaces; like through a magnifying glass. We want to consider a single curved surface. Probably the most common example is the image formed by the curved surface of the side of a drinking glass. An object inside the glass will be magnified by the surface. The amount the surface is curved will be defined by the center of curvature. Once again to find the location of the image we trace two rays from the base of the object through the system. The ray down the axis of the system strikes the surface at normal incidence and is not bent. A ray leaving the object at angle θ_o with strike the surface at the point A making an angle of α to the surface normal. The ray is refracted at an angle β to the normal. The angles α and β are related by Snell's law.

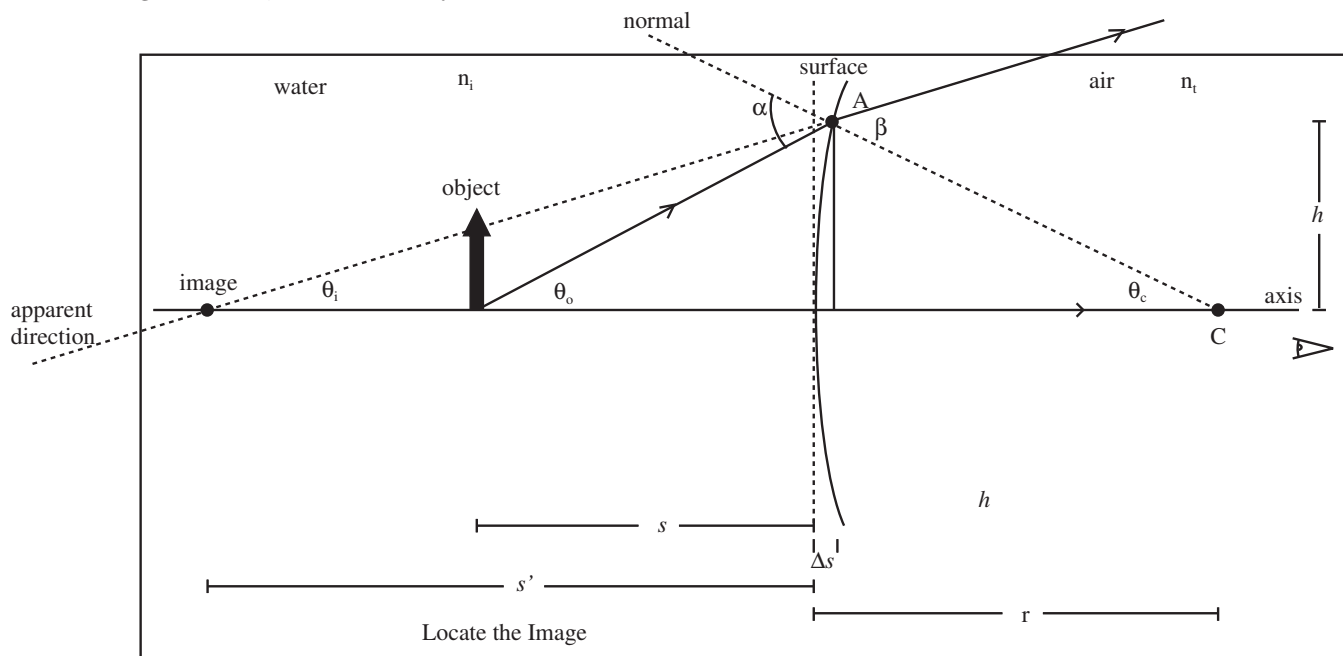

This time we will use the fact that the sum on the angles in a straight line is 180° . Using the line formed by the normal, we can write

$$\alpha + (90^\circ - \theta_o) + (90^\circ - \theta_c) = 180^\circ \Rightarrow \alpha = \theta_o + \theta_c$$

and using the line formed by the outgoing ray and the apparent direction

$$\beta + (90^\circ - \theta_c) + (90^\circ - \theta_i) = 180^\circ \Rightarrow \beta = \theta_i + \theta_c$$

Snell's law in the small angle approximation is $n_i \alpha = n_t \beta$ and substituting yields,

$$n_i(\theta_o + \theta_c) = n_t(\theta_i + \theta_c) \Rightarrow n_i \theta_o - n_t \theta_i = (n_t - n_i) \theta_c$$

Substituting the angles expressed in terms of the image and object distances gives

$$n_i \frac{h}{s} - n_t \frac{h}{s'} = (n_t - n_i) \frac{h}{r}$$

and eliminating h ,

$$\frac{n_i}{s} - \frac{n_t}{s'} = \frac{n_t - n_i}{r}$$

We will adopt a sign convention next section and in that convention s' will be negative for this situation, so the formula for a single interface will be

$$\frac{n_i}{s} + \frac{n_t}{s'} = \frac{n_t - n_i}{r}$$

We can find the magnification by tracing the ray from the point of the object through the vertex. If the incident angle is α and the transmitted angle is β , then the two angles are related by Snell's law, $n_i\alpha = n_t\beta$. The object height is $h_o = \alpha s$ and the image height $h_i = \beta s'$. The image is upright so the magnification is positive. The magnification is

$$m = \frac{h_i}{h_o} = \frac{\beta s'}{\alpha s} = \frac{n_i s'}{n_t s}$$

where I used $\beta = (n_i/n_t)\alpha$ from Snell's law. Once again if we use a sign convention where s' is negative for this situation this will become $m = -\frac{n_i s'}{n_t s}$.

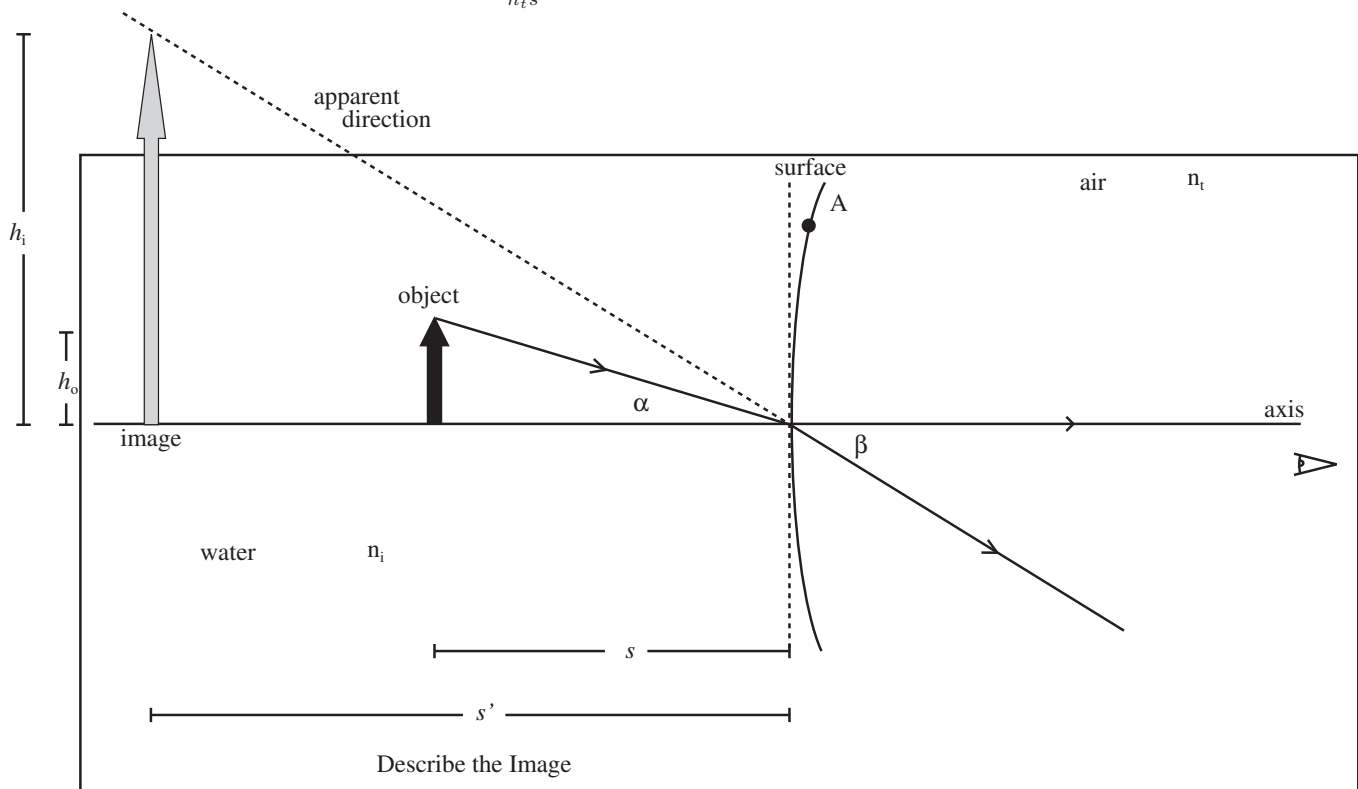

The image is virtual because it is formed of the apparent direction of the outgoing rays. The image is upright and enlarged.

39.3.3 Forming Images by Refraction

In the previous section, we found the equation locating the image formed by refraction at a curved surface for a specific choice of curvature and object location. By adopting a sign convention for when curvatures and distances are positive and negative, this can be turned into an equation that locates the image for a single interface for any curved surface.

Sign Convention for Optics: The positive direction of the optical axis is in the direction that light rays leave the optical element. The object distance to the first interface is always positive.

Single Interface Equation (Thick Lens Equation): Consider now a spherical refractive interface with a certain radius of curvature, r . If an object is in a material of a certain index of refraction, n_i , the light will impinge upon the interface to another material, n_t , and an image will be formed. The distance of the object from the vertex of the interface, s , is related to the distance of the image, s' , from the same via the interface equation

$$\frac{n_i}{s} + \frac{n_t}{s'} = \frac{n_t - n_i}{r}$$

Lateral Magnification of an Image for a Single, Refractive Interface : The image formed as above will have a lateral magnification, m , given by

$$m = -\frac{n_i s'}{n_t s}$$

We worked out the location of the image for a flat surface earlier. Our new universal equation should give the same answer back.

Example 39.1 Frog Observing Bug

Problem: A sticky-tongued frog is 4.0cm below the surface of a still pond. It is looking directly overhead at its next meal: an insect hovering in the air 3.0cm above the surface of the water. The refractive index of water is $4/3$. This problem requires you to use the thick lens equations for both the image location and magnification. The pond has a radius of curvature of infinity, because it is flat.

- (a) How high is the insect above the surface from the frog's viewpoint?
 (b) Does the frog see the insect magnified, reduced, or the same size as if both were in air?

Solution to Part(a)

The frog is looking at the insect, so the light is going from the insect to the frog. Thus, $n_i = 1$ and $n_t = 4/3$. The radius of curvature of the surface is infinity, since you have to have an infinitely big sphere for part of its surface to appear flat. The single-interface equation is

$$\frac{n_i}{s} + \frac{n_t}{s'} = \frac{n_t - n_i}{r}$$

and reduces to

$$\frac{1}{3\text{cm}} + \frac{4/3}{s'} = 0,$$

since $1/\infty = 0$. Solving the equation yields the image distance as $s' = -4\text{cm}$, so the insect appears to be 4cm above the surface of the water (incident side).

Solution to Part(b)

$$m = -\frac{n_i s'}{n_t s} = +1,$$

which will always be the case for a flat surface.

Example 39.2 Fish Viewed from Scuba Mask

Problem: A scuba diver wears a diving mask that bulges outward with a radius of curvature of 0.5m. There is thus a spherical surface between the water ($n = 1.33$) and the air in the mask. Neglect the glass forming the mask. The diver looks at a fish, a distance 1.25m from the mask.

- (a) Compute the location of where the fish appears to be.
 (b) What is the magnification of the fish?
 (c) Draw a diagram showing the system, label positive on the optical axis as well as the location of the fish and its image.

Solution to Part(a)

Light travels from the fish to the observer's eye; therefore, the optical axis is as drawn. The index of refraction of the incident material, water, is $n_i = 1.33 = 4/3$. The index of refraction of the transmitted material, air, is $n_t = 1$. The mask bulges outward as drawn giving a positive radius of curvature once the sign convention is applied $r = +0.5\text{m}$. The object, the fish, is located at $s = 1.25\text{m}$. The image distance is found using the Single Interface Equation:

$$\frac{n_i}{s} + \frac{n_t}{s'} = \frac{n_t - n_i}{r}.$$

Substitute.

$$\frac{4/3}{1.25\text{m}} + \frac{1}{s'} = \frac{1 - 4/3}{0.5\text{m}}$$

Solving yields an image distance of

$$s' = -0.577\text{m}.$$

Solution to Part(b)

For a single curved interface, the magnification is given by

$$m = -\frac{n_i s'}{n_t s} = -\frac{(4/3)(-0.577\text{m})}{(1)(1.25\text{m})} = 0.615.$$

Solution to Part(c)

The diagram is drawn to the right. The point C is the center of curvature of the surface.

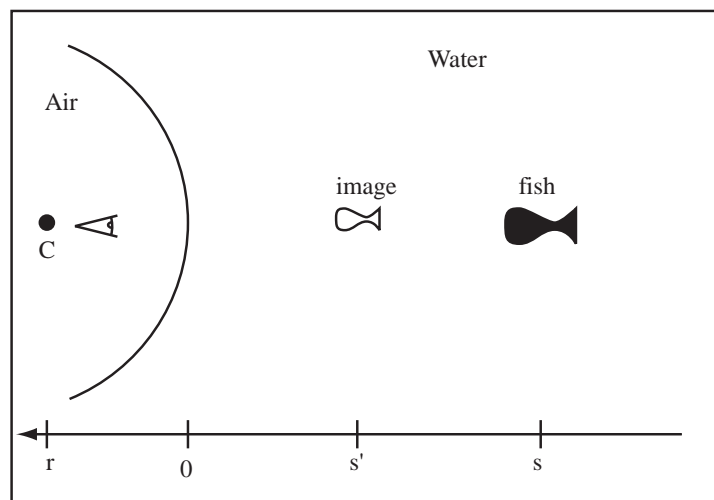

If we have multiple curved surfaces, the first surface light reaches forms an image, called an *intermediate image*. This image becomes the object for the second surface. The total magnification of a multiple interface system is just the product of the magnifications of each surface.

Magnification of Multiple Elements: The magnification, m , of an optical system containing multiple elements is found by multiplying the magnification of each individual element.

$$m = m_1 m_2 \dots m_N$$

Example 39.3 Two Spherical Interfaces on Either End of Refractive Material

Problem: A rod of glass, $n_g = 3/2$, is immersed in water, $n_w = 4/3$, and an object is 48cm in front of the first interface (a). Each end of the rod has a convex spherical interface, the radii of curvature being $r_a = 24\text{cm}$ and $r_b = -12\text{cm}$, where the negative sign for, r_b , is from the sign convention. The rod is 2.0m long. Locate the image formed by this rod.

Solution

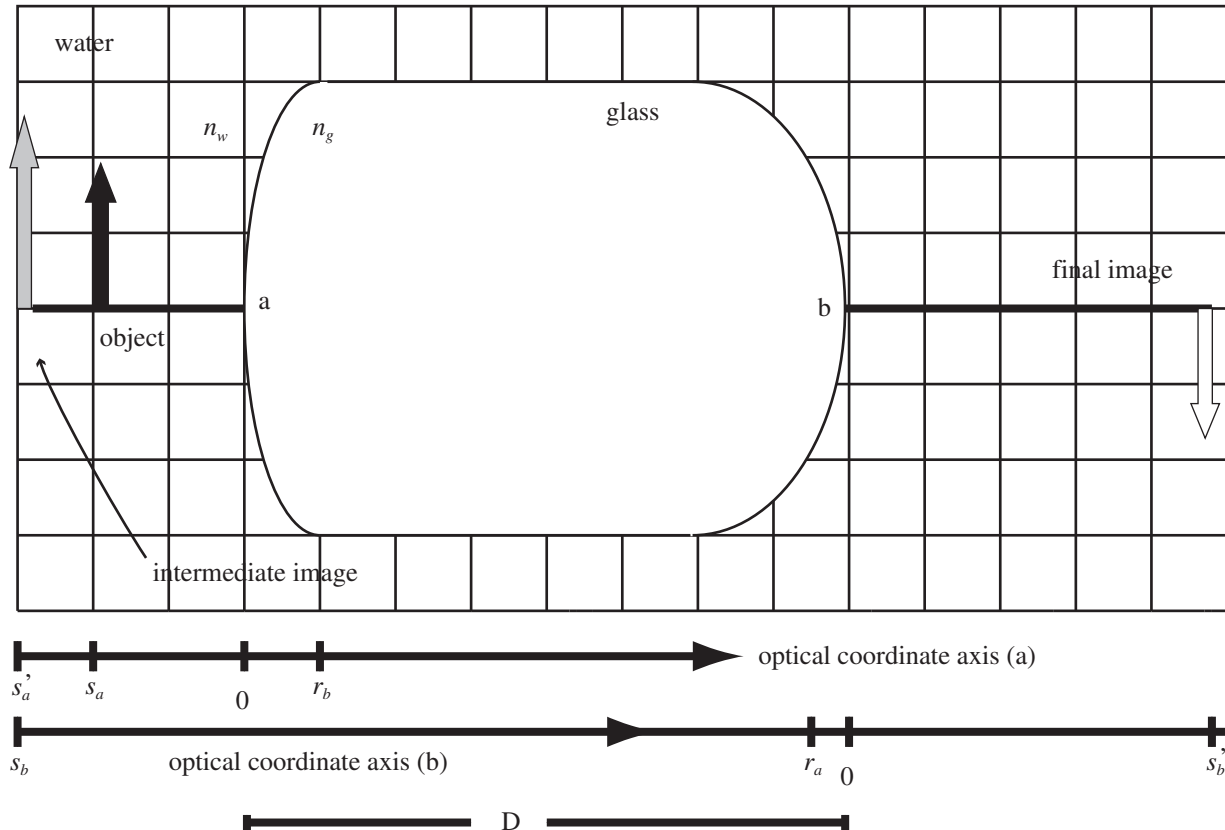
Definitions

- $r_a = 24\text{cm} \equiv$ Radius of curvature for interface a
- $r_b = -12\text{cm} \equiv$ Radius of curvature for interface b
- $n_w = 4/3 \equiv$ Index of refraction for the outside material
- $n_g = 3/2 \equiv$ Index of refraction for the inside material
- $s_a = 48\text{cm} \equiv$ Distance of object from interface a
- $s'_b \equiv$ Distance of image from interface b
- $s'_a \equiv$ Distance of intermediate image from interface a
- $s_b \equiv$ Distance of intermediate object from interface b
- $d = 2.0\text{m} \equiv$ Separation between the optical interfaces

(a) Draw the Optical System: Drawn the real optical axis and place the optical elements on the axis. Draw an optical coordinate axis for each interface.

(b) Compute the Image Distance as Formed by Interface a: Use Interface equation for the first interface

$$\frac{n_i}{s} + \frac{n_t}{s'} = \frac{n_t - n_i}{r} \longrightarrow \frac{n_w}{s_a} + \frac{n_g}{s'_a} = \frac{n_g - n_w}{r_a}$$

and solve for the intermediate image distance s'_a . From the diagram the radius of the first interface (a) is positive. Solve the interface equation for s'_a

$$s'_a = n_g \left(\frac{n_g - n_w}{r_a} - \frac{n_w}{s'_a} \right)^{-1} = \frac{3}{2} \left(\frac{3/2 - 4/3}{24\text{cm}} - \frac{4/3}{48\text{cm}} \right)^{-1} = -72\text{cm}$$

The intermediate image forms farther from the first interface than the object, as drawn.

(c) Calculate the Magnification of Interface (a): The magnification for a single interface is

$$m = -\frac{n_i s'}{n_t s}$$

where n_i is the index of refraction where the light originates and n_t is the index of refraction where light is transmitted.

$$m_a = -\frac{n_w s'_a}{n_g s_a} = -\frac{\frac{4}{3}(-72\text{cm})}{\frac{3}{2}(48\text{cm})} = 1.33$$

(d) Calculate the Object Distance for Interface (b): The object for the second interface is the image formed by the first interface. The distance between the optical interfaces must be accounted for, which means

$$s_b = d - s'_a$$

The image from the first interface is a virtual image.

$$s_b = d - s'_a = 200\text{cm} - (-72)\text{cm} = 272\text{cm}$$

(e) Calculate the Image Distance as Formed by Interface (b): Use Interface equation for the second interface

$$\frac{n_i}{s} + \frac{n_t}{s'} = \frac{n_t - n_i}{r} \longrightarrow \frac{n_g}{s_b} + \frac{n_w}{s'_b} = \frac{n_w - n_g}{r_b}$$

and solve for the intermediate image distance s'_b . Note from its placement on the optical coordinate axis, $r_b < 0$.

SPECIAL NOTE: Since the light comes through n_g first, that is the index that is associated with the object distance for the second interface. Solve the interface equation for s'_b

$$s'_b = n_w \left(\frac{n_w - n_g}{r_b} - \frac{n_g}{s_b} \right)^{-1} = \frac{4}{3} \left(\frac{4/3 - 3/2}{-12\text{cm}} - \frac{3/2}{272\text{cm}} \right)^{-1} = 159\text{cm} = 1.6\text{m}$$

(f) Calculate the Magnification of Interface (b): The magnification for a single interface is

$$m = -\frac{n_i s'}{n_t s}$$

where n_i is the index of refraction where the light originates, this time the glass, and n_t is the index of refraction where light is transmitted, this time the water.

$$m_a = -\frac{n_g s'_b}{n_w s_b} = -\frac{\frac{3}{2}(160\text{cm})}{\frac{4}{3}(272\text{cm})} = -0.66$$

(g) Calculate the Total Magnification: The total magnification is the product the magnifications of the individual elements,

$$m_T = m_1 m_2 = (1.33)(-0.66) = -0.88$$

The final image is inverted ($m_T < 0$), reduced ($|m_T| < 1$), and real ($s'_b > 0$).

39.3.4 A Thin Lens

A thin lens is formed of two spherical surfaces of radius r_1 and r_2 . The surfaces are spaced a distance d apart as shown below. Outside the lens the index of refraction is n_0 and inside the lens the index of refraction is n . The object is at s . The first surface light reaches, surface 1, forms an image at location s'_1 . This image becomes the object for the second surface which forms an image at s' . The object distance for the second surface is $s_2 = d - s'_1$. The problem of the thin lens is exactly like the previous example except we will eventually assume the distance between the two surfaces, d , is small.

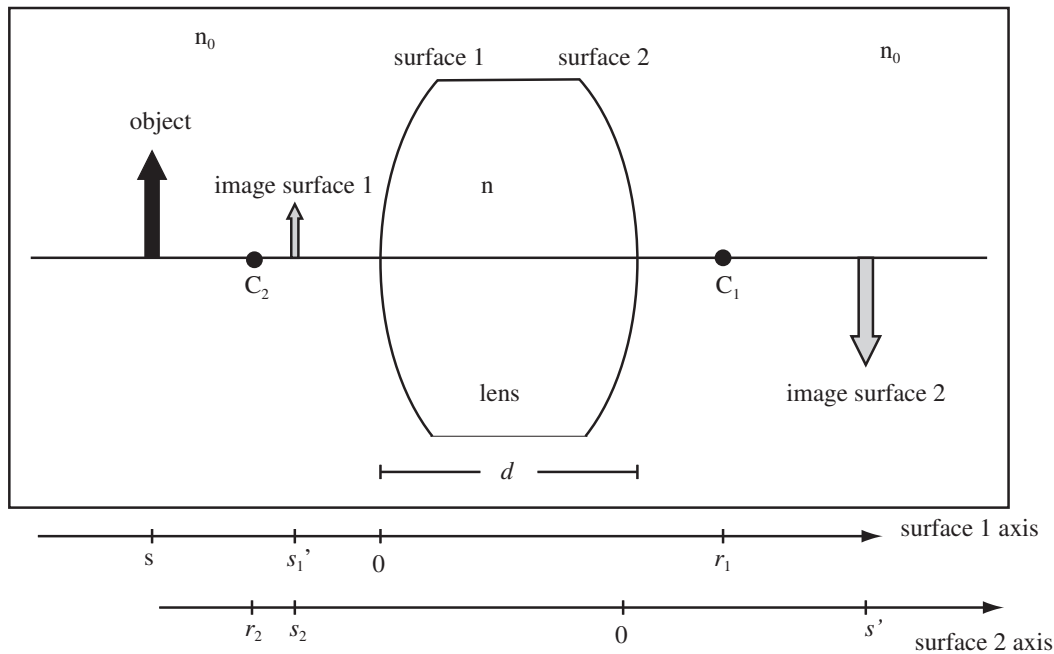

The single interface equation for the first surface is

$$\frac{n_0}{s} + \frac{n}{s'_1} = \frac{n - n_0}{r_1}$$

and for the second surface using $s_2 = d - s'_1$,

$$\frac{n}{d - s'_1} + \frac{n_0}{s'} = \frac{n_0 - n}{r_2}$$

If we assume d is very small compared to s'_1 , the second equation becomes

$$-\frac{n}{s'_1} + \frac{n_0}{s'} = \frac{n_0 - n}{r_2}$$

If we add the two equations, the terms containing the intermediate image distance cancel out and we get

$$\frac{n_0}{s} + \frac{n_0}{s'} = \frac{n - n_0}{r_1} + \frac{n_0 - n}{r_2} = (n - n_0) \left(\frac{1}{r_1} - \frac{1}{r_2} \right)$$

The total magnification of the lens is the product of the magnifications of the individual surfaces,

$$m = m_1 m_2 = \left(-\frac{n_0 s'_1}{n s} \right) \left(-\frac{n s'}{n_0 (d - s'_1)} \right) = -\frac{s'}{s}$$

if d is small.

Image Location of a Thin Lens: The image formed by a thin lens is located by

$$\frac{1}{s} + \frac{1}{s'} = \frac{(n - n_0)}{n_0} \left(\frac{1}{r_1} - \frac{1}{r_2} \right)$$

where n is the index of refraction of the lens and n_0 is the index of the material outside of the lens. The magnification of the thin lens is $m = -s'/s$.

Thin Lens Approximation Part II: A thin lens is a lens where the distance between the curved surfaces is small compared to the intermediate image distance of the first surface.

Chapter 40

Thin Lenses and Mirrors

40.1 Image Formation Using Mirrors

40.1.1 Types of Mirrors

We will work with spherical mirrors, mirrors whose surfaces are sections of a thin reflecting spherical shell. The mirrors are classified by whether the reflecting surface bends outward or inward. There are three types of spherical mirrors. The mnemonic we will use to remember which is which is “concave caves in”.

Types of Mirrors:

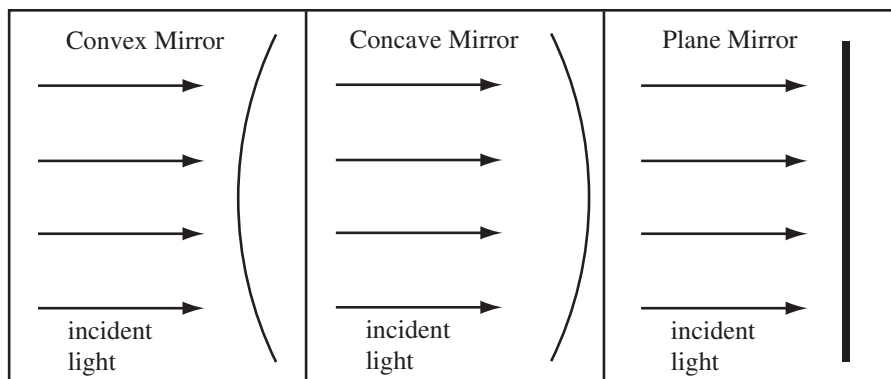

A plane mirror is a section of an infinitely large sphere.

40.1.2 Focal Point and Focal Length of a Mirror

Light rays originating from a point light source spread out radially as they travel. Far away from any light source, the light rays become nearly parallel.

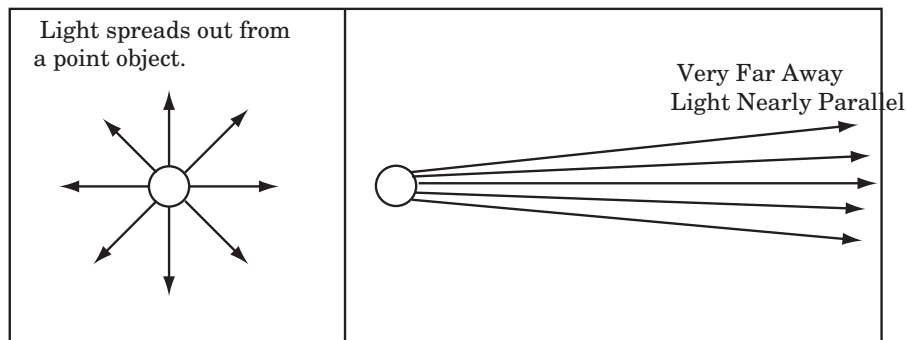

Therefore, light rays from the sun are very, very nearly parallel. We can also make parallel light rays using an appropriately constructed optical system. Parallel light rays are very useful. If we shine parallel light rays on a curved mirror, the light rays, or the direction the light rays appear to come from, will converge at a point. This point is called the *focal point*.

Definition of Focal Point: The point where incoming parallel light rays cross or the apparent direction where incoming parallel light rays appear to cross. Note this is the secondary focal point for a lens, the primary focal point is the point where a point light source could be placed to generate parallel rays.

For the concave mirror system below, the parallel light rays all reflect to a point. For the convex mirror system, the reflected light rays appear to originate from a point behind the mirror. The direction the rays appear to come from is the *apparent direction*. The apparent direction is shown as dashed lines on the diagram. The point where the light or the light's apparent direction converges is called the *focal point* of the optical system, and is labelled F .

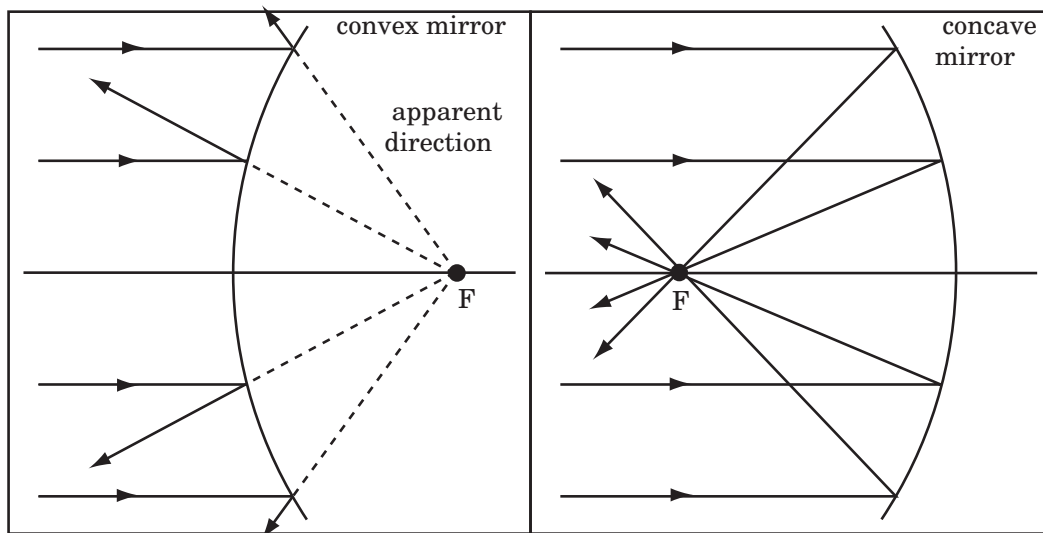

Focal Length of a Spherical Mirror: The focal length, f , of a spherical mirror is distance from the point the optical axis intersects the mirror to the focal point of the mirror.

Last chapter, we found the image location, s' , for a spherical mirror was related to the object location, s , by

$$\frac{1}{s} + \frac{1}{s'} = \frac{2}{r}$$

where r is the radius of curvature. To find the focal length, we need to find where parallel rays are focused. To produce parallel rays, use an object that is infinity far from the mirror. The image of this object will be at the focal point, so $s = \infty$ and $s' = f$.

$$\frac{1}{\infty} + \frac{1}{f} = \frac{2}{r}$$

so the focal length of a mirror is $f = r/2$.

Mirror Maker's Equation: The focal length, f , of a spherical mirror is half the radius of curvature, r , of the mirror,

$$f = \frac{r}{2}.$$

40.1.3 Landmarks of Spherical Mirrors

A light ray that strikes a mirror perpendicular to the surface is reflected directly back along itself: since the angle of incidence is zero, the angle of reflection is zero. The path of this light ray is called the optical axis of the system. To help organize our calculations, we will also draw a copy of this axis below the diagram of the system. This will be the coordinate axis for our calculations. The point where the optical axis crosses the mirror or the center of the lens will be the origin of the coordinate system. We will call this point the vertex of the mirror. This is indicated by drawing the point “0” on the coordinate axis below the drawing. To be useful in mathematical calculations, the positive and negative directions of a coordinate system must be defined. For optical systems, the positive direction of the coordinate axis is chosen using the following convention:

Sign Convention for Optics: The positive direction of the optical axis is in the direction that light rays leave the optical element. The object distance to the first interface is always positive.

For mirrors, if the incident light comes in from the left, it reflects off the mirror and leaves to the left. For lenses the light passes through the element, so if incident light is from the left, the light leaves the system to the right.

The Optical Axis: The optical axis of an optical system is a line that passes through each optical element perpendicular to the surface of the element. We will also use an optical coordinate axis drawn below the optical system to show the locations of the variables in our optical calculations.

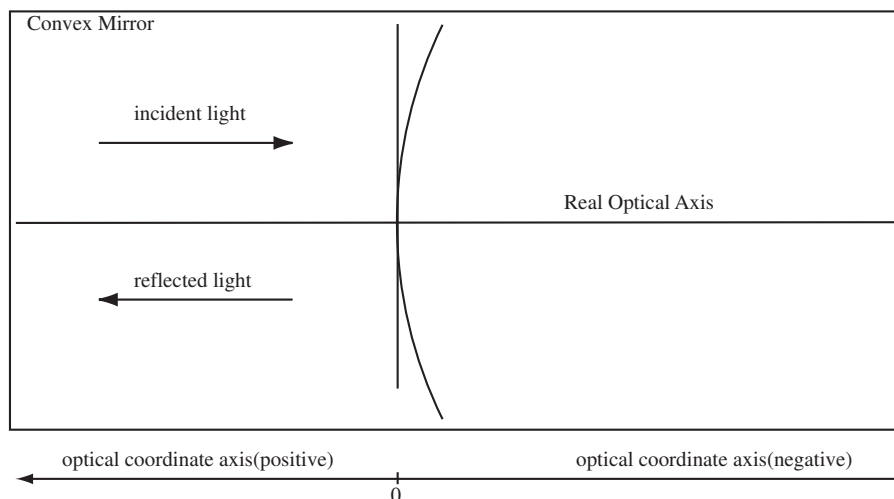

Thin Lenses and Mirrors: The mirrors and lenses we analyze are called thin lenses and mirrors. This means the thickness or the lens or radius of curvature of the mirror is such that the light rays appear to refract or reflect off a plane through the center of the lens or mirror. An exaggerated cartoon of the lens or mirror will usually be drawn, but along with it will be a plane that defines the mathematical location of the thin lens or mirror.

The optical coordinate axis clearly shows the direction, which the sign convention gives as positive, and the location of important distances in the optical system: radii of curvature, focal lengths, the object, and image distances. The origin of the optical axis is the location where the optical axis intersects the mirror. Both the real optical axis and the optical coordinate axis will be referred to as the optical axis.

The behavior of a spherical mirror as an optical element is determined by two points that lie on the real optical axis, the center of curvature, C , and the focal point, F . With these points are associated two distances along the optical coordinate axis, the radius of curvature, r , and the focal length f . Both these distances have signs given by our sign convention. They are positive if they are on the positive side of the optical coordinate axis (from zero) and negative if they are on the negative side.

Center of Curvature: A spherical mirror is a mirror that is some section of a reflecting spherical shell. The center of curvature is a point at the center of the shell. It is given the label C .

Radius of Curvature: The radius of curvature, r , is the distance from the center of curvature to the point the optical axis crosses the mirror. It is the radius of the sphere of which the mirror is a section. The radius of curvature has sign given by the sign convention for optics.

Focal Point for a Mirror: The focal point is a point on the real optical axis where incident parallel light rays are focused (concave mirror) or appear to be focused (convex mirror). The focal point is given the label F .

A couple of examples to illustrate these definitions: first a convex mirror, then a concave mirror. In both cases, we have to illustrate the direction of the incident light. We will save plane mirrors until we can mathematically locate images, because both the focal point and the center of curvature of a plane mirror are at infinity.

Example 40.1 Landmarks of a Convex Mirror

Problem: A convex mirror is formed from a section of a sphere of radius 20cm.

- Draw the mirror, the optical axis, the location of the focal point, and the location of the center of curvature.
- Draw the optical coordinate axis, clearly labelling positive and negative on the axis. Then mark the radius of curvature, r , and the focal point f on the optical axis.
- Compute the signed value of the focal length and the radius of curvature.

Solution to Part (a)

Draw the optical axis through the center of the mirror and a representation of the lens that bends in the correct direction. The curvature of a convex mirror is as shown below. The center of curvature, C , for this mirror is as drawn. For all mirrors, the focal point, F , is halfway between the center of curvature and the mirror as drawn.

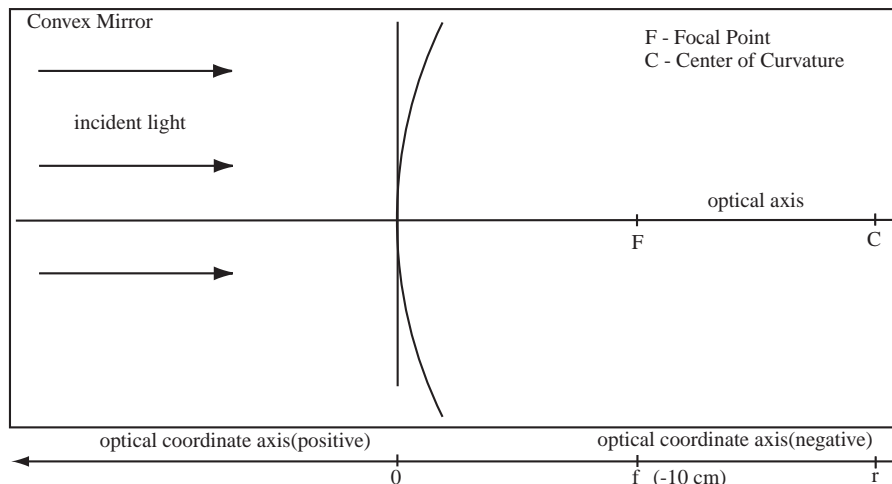

Solution to Part (b)

Draw the Optical Coordinate Axis and Locate Landmarks: The optical coordinate axis is drawn below the mirror in the figure above. The sign convention tells us that positive on the optical axis is on the reflected side of the mirror. Since light bounces off of a mirror, the reflected side is the same as the incident side, so positive and negative on the optical axis are as drawn. The points f and r , the focal length and radius of curvature, are located directly below the focal point and center of curvature.

Solution to Part (c)

Compute Focal Length and Radius of Curvature: Since the focal point and center of curvature are on the negative part of the optical axis, the signed radius of curvature is $r = -20\text{cm}$ and the signed focal length is $f = r/2 = -10\text{cm}$.

Example 40.2 Landmarks for Concave Mirror

Problem: A concave mirror has focal length of magnitude $|f| = 30\text{cm}$.

- (a) Draw the mirror, the optical axis, the location of the focal point, and location of the center of curvature.
- (b) Draw the optical coordinate axis, clearly labelling positive and negative on the axis, then mark the radius of curvature, r , and the focal point f on the optical axis.
- (c) Compute the signed value of the focal length and the radius of curvature.

Solution to Part (a)

Locate the Center of Curvature and the Focal Point: Draw the real optical axis through the center of the mirror. Draw a cartoon (numerical value of radius not maintained) of the mirror that curves in the right direction. The curvature of a concave mirror is as shown below. The center of curvature, C , for this mirror is as drawn, and for all mirrors, the focal point, F , is halfway between the center of curvature and the mirror as drawn.

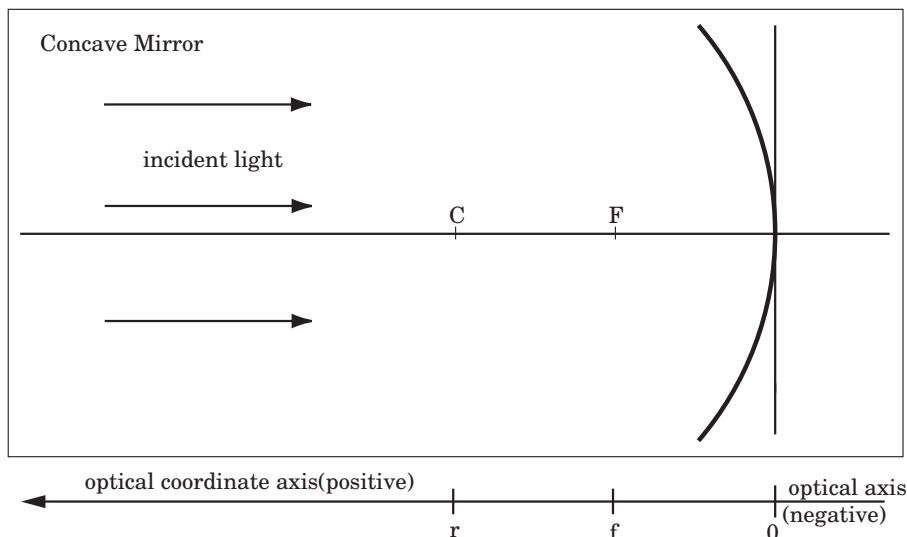

Solution to Part (b)

Draw the Coordinate Optical Axis and Locate Landmarks: The optical coordinate axis is drawn below the mirror. The sign convention tells us that positive on the optical axis is on the reflected side of the mirror as drawn. The points f and r , the focal length and radius of curvature, are located directly below the focal point and center of curvature.

Solution to Part (c)

Compute the Focal Length: Since they are on the positive part of the optical axis, both are positive for this mirror. Therefore, the signed radius of curvature is $r = 60\text{cm}$ and the signed focal length is $f = r/2 = 30\text{cm}$

40.1.4 Ray Tracing for Spherical Mirrors

The game in optics is to figure out the location and properties of the image formed by shining light on an object a certain distance from an optical system. For an image to form, all light leaving the object from each point must be brought to the same point on the image. In this chapter, we assume that light travels in straight lines. Therefore, we can find the image by taking each light ray leaving a point on the object and following it through the optical system. The location where the various light rays leaving an object intersect is the location of the image. This method of locating the image is called *ray tracing* and is one of the more beautiful applications of graphical technique in science. The problem is that for most rays leaving an object, following the ray through an optical system is difficult. The strategy is then to find a few of the rays which we can trace easily and that is why the focal point and the radius of curvature are so important.

No matter what the shape of the surface, the angle of incidence equals the angle of reflection. The focal point of a mirror is chosen so that any parallel ray will have equal angles of incidence and reflection when the reflected ray passes through the focal point. The tail of the object arrow is placed on the optical axis. A ray travelling along the optical axis is reflected directly back along the optical axis, so the tail of the image arrow will also sit on the optical axis.

The location of the object is represented by the symbol s on the optical coordinate axis. The location of the image is represented by the symbol s' on the optical coordinate axis.

To draw the ray diagram do the following:

- Draw the mirror with correct direction of curvature.
- Draw and label the focal point (F) and the center of curvature (C).

- Indicate the positive direction on the optical axis.
- Draw the location of the points s , f , and r on the optical axis. Indicate using > 0 and < 0 whether these quantities are positive or negative.
- Draw the Parallel Ray and label it (P). The parallel ray leaves the object parallel to the axis and is reflected through the focal point. Remember to draw the apparent direction as a dashed line.
- Draw the Focal Ray and label it (FF). The focal ray travels from the object through the focal point and is reflected parallel to the axis, if the object is outside of the focal point. If the object is inside the focal point, the ray is on the line from the focal point and to the object, then is reflected parallel.
- Draw the Central Ray and label it (CC). The central ray reflects off of the center of the mirror with the incident angle equal to the reflected angle.
- Draw the Radial Ray and label it (R). The radial ray lies on the line from the center of curvature to the object. The ray is reflected directly back along the line.

We will illustrate ray tracing in the examples of the next section. If you have any questions about how to draw a particular ray, next chapter is an exhaustive reference on ray tracing with additional examples.

40.1.5 Mathematically Locating the Image for a Spherical Mirror System

The ray tracing techniques above allow us to approximately locate and describe the image of a spherical mirror if we can locate the focal point of the mirror. To calculate the image location for either a mirror or a lenses, the strategy is the same. Beg, borrow, steal, or calculate the focal points of the optical elements in your system, then apply the equation for the type of element you are working with to get the image distance. We can also exactly locate and describe the image mathematically. The location of the image is given by:

Mirror Equation: The distance of the image, s' , from the vertex of the mirror (0 on the optical axis) can be found from the mirror equation

$$\frac{1}{s} + \frac{1}{s'} = \frac{1}{f}$$

where s is the object distance and f the focal length. The object distance is always positive if you are looking at a real thing, but the focal length and the image distance conform to the sign convention.

To describe an image we need to tell whether it is upright or inverted, enlarged or reduced, and real or virtual. We can calculate each of these properties from the object and image distance through the numerical expression for the magnification m :

Lateral Magnification Due to a Spherical Mirror : An image formed by reflection from a spherical mirror will have a lateral magnification, m , given by

$$m = -\frac{s'}{s}$$

The $-$ sign comes from the fact that a real image ($s' > 0$) is inverted ($m < 0$).

The following two examples illustrate using the mirror equation and the mathematical expression for magnification of a convex or concave mirror.

Example 40.3 Compute the Image of a Concave Mirror

Problem: A concave mirror has a radius of curvature of 45cm. An object is 1.0m from the vertex. Compute the image distance, interpret the image, and draw a ray diagram.

Solution

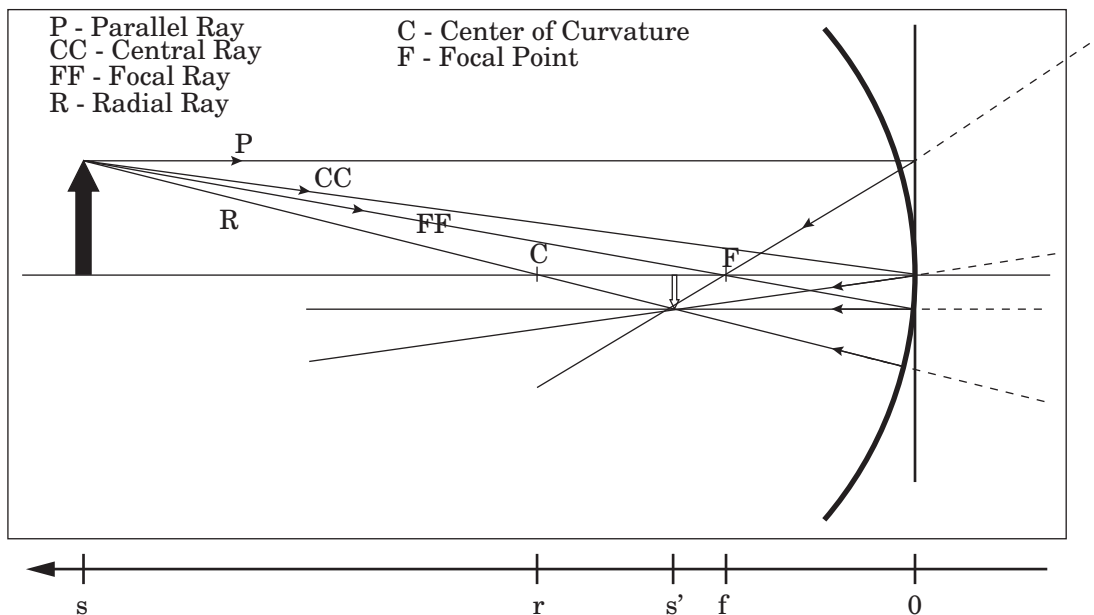

Definitions

$s = 1\text{m} \equiv$ Object Distance

$r = 45\text{cm} \equiv$ Radius of Curvature

$s' \equiv$ Image Distance

$m \equiv$ Magnification

(a) Compute the Focal Length: The radius of curvature is given as $r = 45\text{cm}$, therefore the focal length is $f = r/2 = 22.5\text{cm}$. For a concave mirror, the focal length is on the transmitted side and is therefore positive.

(b) Compute the Image Distance: Use the mirror equation to find the image distance. The information given is object distance,

$$\begin{aligned} \frac{1}{s} + \frac{1}{s'} &= \frac{1}{f} \longrightarrow s' = \left(\frac{1}{f} - \frac{1}{s} \right)^{-1} \\ &= \left(\frac{1}{0.225\text{m}} - \frac{1}{1.0\text{m}} \right)^{-1} \end{aligned}$$

$$s' = 0.29\text{m} = 29\text{cm}$$

(c) Compute the Magnification: Use $m = -s'/s$

$$m = -\frac{0.29\text{m}}{1.0\text{m}} = -0.29$$

(d) Mathematically Interpret the Image: This is a real, $s > 0$, reduced $|m| < 1$, inverted $m < 0$ image.

(e) Draw Ray Diagram: Draw the mirror with the approximate radius of curvature, and the real optical axis through the vertex. At the intersection of the vertex and the mirror, draw the plane from which the rays will be reflected. Draw all principle rays.

- Parallel Ray (P) - Drawn parallel to the axis and bounces back through the focal point.
- Focal Ray (FF) - Drawn through focal point, bounces back parallel to the axis.
- Central Ray (CC) - Drawn to the vertex, bounces back with equal angle of reflection.
- Radial Ray (R) - Drawn through center of curvature, bounces directly back.

Where they intersect is the image, and should approximately agree with the calculated image distance and magnification. If we do not draw the diagram to scale, tracing rays will not reproduce the answer. The more accurate the scale of the drawing, the better the agreement should be. Draw the optical coordinate axis below the figure.

Example 40.4 Convex Mirror Image Formation

Problem: A convex mirror has radius of curvature of magnitude 8cm. An object is placed a distance 6cm from the mirror.

- Compute the image distance.
- Compute the magnification of the image.
- Describe the image.
- Draw the ray diagram.

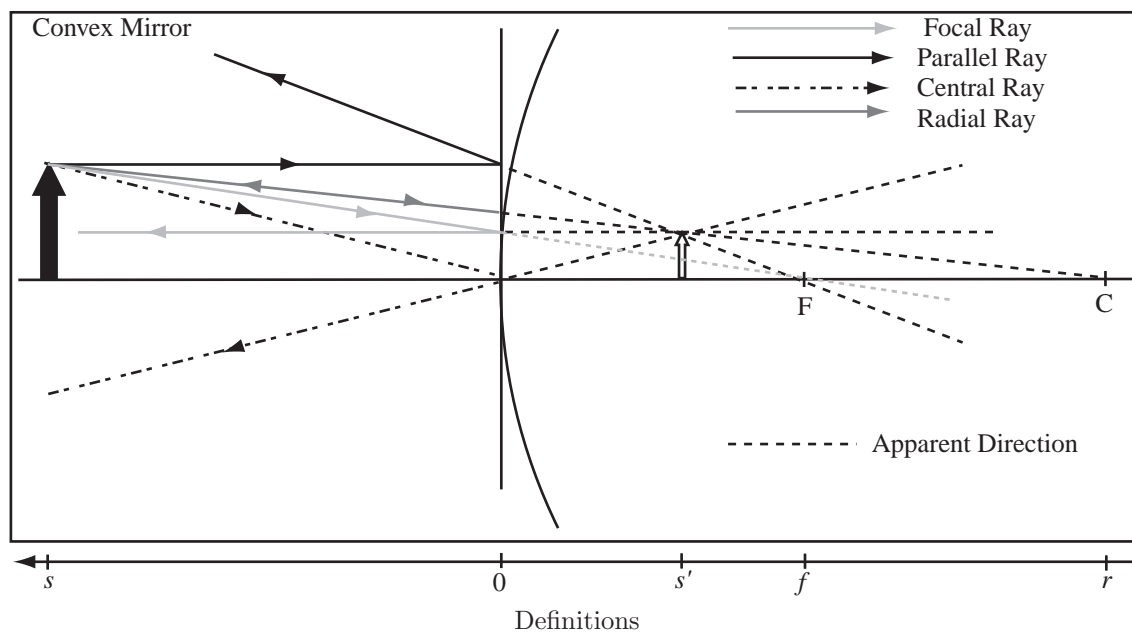

$r = -8\text{cm} \equiv$ Radius of Curvature
 $f \equiv$ Focal Length of Mirror
 $s = 6\text{cm} \equiv$ Object Distance
 $s' \equiv$ Image Distance
 $m \equiv$ Magnification
 $C \equiv$ Center of Curvature
 $F \equiv$ Focal Point

Strategy: Compute the image location, then draw the ray diagram. Use image location to compute the magnification.

Solution to Part (a)

(a) Compute the Focal Length: The focal length is half the radius of curvature $|f| = r/2 = 4\text{cm}$. For a convex mirror, the focal point is behind the mirror, so $f = -4\text{cm} < 0$.

(b) Compute the Image Location: The image location is given by the mirror equation

$$\frac{1}{s} + \frac{1}{s'} = \frac{1}{f}$$

or solving for s'

$$s' = \frac{1}{\frac{1}{f} - \frac{1}{s}} = \frac{1}{\frac{1}{-4\text{cm}} - \frac{1}{6\text{cm}}}$$

$$s' = -\frac{12}{5}\text{cm} = -2.4\text{cm}$$

Solution to Part (b)

Compute the Magnification: By definition, the magnification of the image is,

$$m = -\frac{s'}{s} = -\frac{(-\frac{12}{5}\text{cm})}{(6\text{cm})} = \frac{2}{5} = 0.4$$

Solution to Part (c)

Describe the Image: The image is reduced, since $|m| < 1$, upright $m > 0$, and virtual $s' < 0$. All of this can be read from the ray diagram, the drawn image is smaller, the same orientation as the object, and formed by the apparent direction of the rays.

Solution to Part (d)

Draw the Ray Diagram: Draw the mirror with correct direction of curvature and the plane through the vertex from which we will draw the reflected rays. Draw the focal ray, central ray, parallel ray, and radial ray for the mirror. This should converge to an image at approximately the image distance. This will approximately happen if the object, focal point, and center of curvature are drawn to scale. The radial ray is drawn from the object through the center of curvature C . The central ray is drawn, reflected at the point the mirror meets the axis. The parallel ray is drawn parallel to the axis on the object side of the mirror, then appears to bend toward the focal point. The reflection of this ray is in the same direction as the line through the focal point. The focal ray is drawn from the object towards the focal point. The reflection of this ray is parallel to the axis.

40.2 Image Formation by Thin Lenses

40.2.1 Working with Thin Lenses

Image formation by lenses works about the same way as image formation using mirrors; we can approximately locate the image using similar ray tracing methods. We will work with thin lenses, which are lenses where the thickness of the lens is much smaller than the object distance. The key feature of a lens is the same as the key feature of a mirror, the focal length. The first thing we have to learn is how to locate the focal point. For lenses there are two cases; (I) The point where a point source can be placed to generate outgoing parallel rays, the primary focal point, (II) The point where incoming parallel rays are focused, the secondary focal point.

Not A New Sign Convention: For lenses we will use a sign convention that the image distance and the radius of curvature are positive if they are on the transmitted side of the lens. Unlike mirrors the transmitted side is not the same side as the incident side. Object distance is positive on the incident side of the lens.

Two Radii of Curvature: A thin lens has two centers of curvature, C_1 and C_2 , one for each side of the lens. The center of curvature C_1 is for the surface the incident light reaches first. The center of curvature C_2 is the surface the light reaches second. The radii of curvature r_1 and r_2 are found by measuring the location of the centers of curvature along the optical axis. The radii of curvature conform to the sign convention.

To locate the image, s' , of a thin lens given the location of the object s , we found the equation

$$\frac{1}{s} + \frac{1}{s'} = \frac{n - n_0}{n_0} \left(\frac{1}{r_1} - \frac{1}{r_2} \right)$$

If the index of refraction of the lens is n and the lens is placed in air, this becomes

$$\frac{1}{s} + \frac{1}{s'} = (n - 1) \left(\frac{1}{r_1} - \frac{1}{r_2} \right)$$

To find the focal length, find the location where parallel light rays are focused, this will be the place an object at infinity is focused, so if $s = \infty$ then $s' = f$. In air,

$$\frac{1}{\infty} + \frac{1}{f} = (n - 1) \left(\frac{1}{r_1} - \frac{1}{r_2} \right) = \frac{1}{f}$$

Lens-maker's Equation : For a converging (convex) lens, all light which comes in parallel to the axis will be focused through the *secondary* focal point, F' . For a diverging (concave) lens, the apparent direction of all light that comes in parallel to the axis will pass through the *secondary* focal point. This leads to a relationship that will describe the focal length of a lens—the lens-maker's equation:

$$\frac{1}{f} = (n - 1) \left(\frac{1}{r_1} - \frac{1}{r_2} \right)$$

This yields a focal length with appropriate sign to locate the secondary focal point.

Focal Length Same for Both Sides: The focal length is the same for a thin lens for either orientation of the lens with reference to the direction of incident light.

Converging and Diverging Lenses: A **converging** lens causes light rays from infinity to be focused at the secondary focal point on the transmitted side of the lens by causing the rays to bend closer together (to converge). A **diverging** lens causes the apparent direction of light rays from infinity to focus at the secondary focal point on the incident side of the lens. **The focal length of a diverging lens is negative and the focal length of a converging lens is positive.**

Secondary Focal Point (F'): The focal point where the incident parallel light is focused (converging lens) or the apparent direction is focused (diverging lens), is the *secondary focal point* and is designated as F' on the ray diagram. The other focal point is the primary focal point and is designated F on the ray diagram.

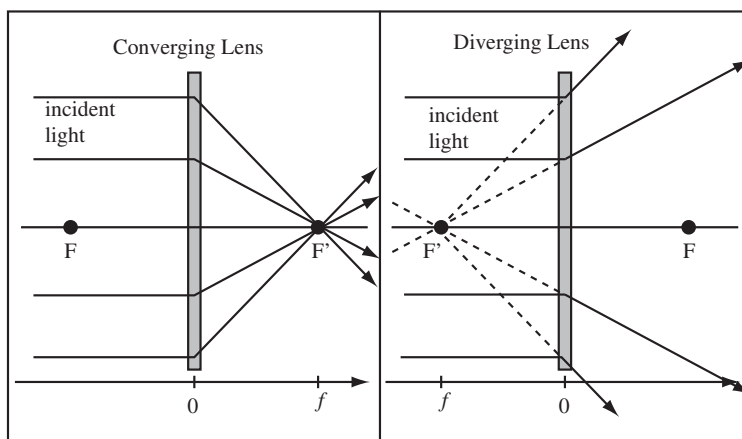

Primary Focal Point (F): The primary focal point is the point where a point light source could be placed to produce outgoing parallel rays (converging lens) or where light rays should be sent toward to produce outgoing parallel rays (diverging lens).

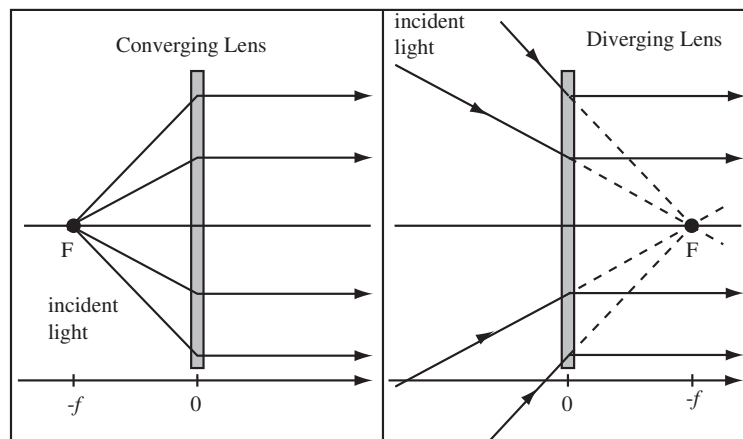

Types of Lenses: The figure below shows the types of lenses which can be formed of sections of spherical surfaces. The radius of curvature and focal length of a plane is infinity, therefore the contribution to the focal length in the lens maker's equation is $1/r = 1/\infty = 0$. If one plays with the lensmaker's equation, one will find for lenses in air that a convex lens always has a positive focal length and is therefore a converging lens and a concave lens always has negative focal length and is therefore a diverging lens.

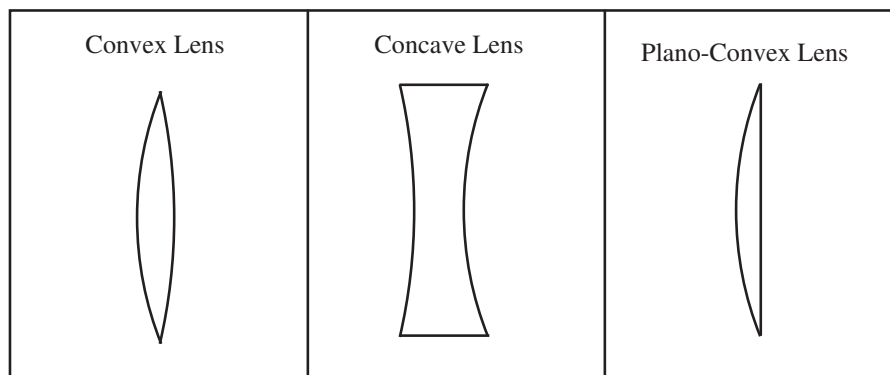

Example 40.5 Focal Lengths of Unusual Lenses

Problem: Not all lenses are simple convex or concave lenses. This problem asks you to compute the focal lengths of a couple of more interesting lenses ground out of glass with index of refraction 1.66. The lens in figure (a) is a plano-convex lens, where the convex surface has a radius of curvature of magnitude, $|r| = 20\text{cm}$. The lens in figure (b) is a combination of a convex and concave lens, where the convex surface has radius with magnitude $|r| = 20\text{cm}$ and the concave surface has radii of curvature $|r| = 10\text{cm}$.

- (a) For lens (a), compute the focal length and tell whether the lens is converging or diverging. Also, draw the lens and its optical axis showing the location of each center of curvature and the primary and secondary focal points.
- (b) For lens (b), compute the focal length and tell whether the lens is converging or diverging. Also, draw the lens and its optical axis showing the location of each center of curvature and the primary and secondary focal points.

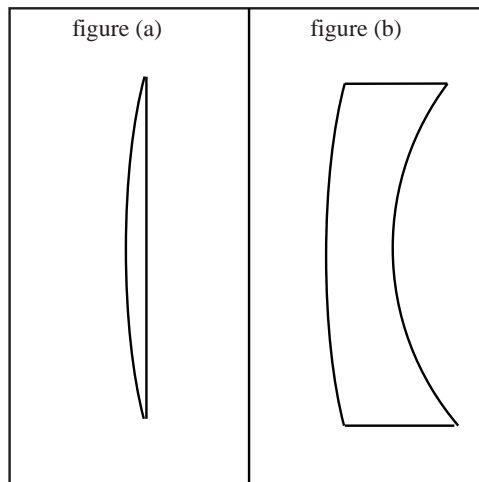

Solution for Lens (a)

The radii of curvature for the lens (with appropriate signs) are $r_1 = 20\text{cm}$ and $r_2 = \infty$. Apply the lens maker's equation,

$$\frac{1}{f} = (n - 1) \left(\frac{1}{r_1} - \frac{1}{r_2} \right) = (1.66 - 1) \left(\frac{1}{20\text{cm}} - \frac{1}{\infty} \right).$$

$$\frac{1}{f} = \frac{0.66}{20\text{cm}}$$

$$f = 30\text{cm}$$

Since the focal length is positive, the secondary focal point, F' , is on the transmitted side of the lens and the lens is a converging lens.

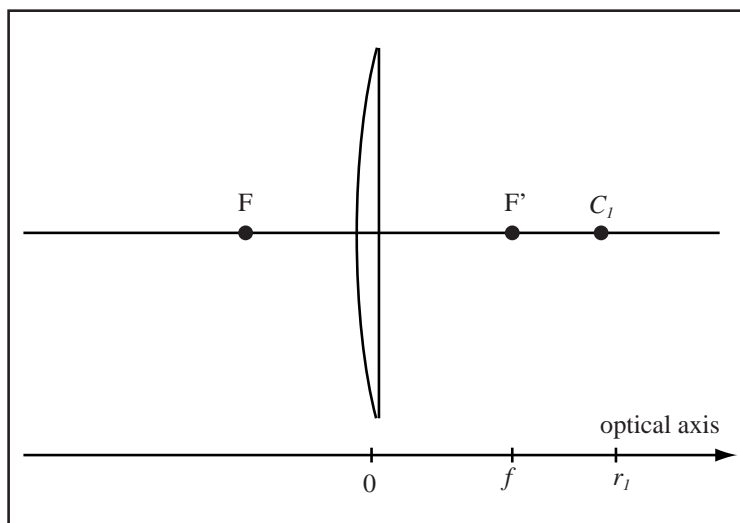

Solution for Lens(b)

The radii of curvature for the lens (with appropriate signs) are $r_1 = 20\text{cm}$ and $r_2 = 10\text{cm}$. Apply the lens maker's equation,

$$\frac{1}{f} = (n - 1) \left(\frac{1}{r_1} - \frac{1}{r_2} \right) = (1.66 - 1) \left(\frac{1}{20\text{cm}} - \frac{1}{10\text{cm}} \right).$$

$$\frac{1}{f} = -\frac{0.66}{20\text{cm}}$$

$$f = -30\text{cm}$$

Since the focal length is negative, this is a diverging lens. The secondary focal point, F' , is placed a focal length from the lens on the incident side of the lens, with the primary focal point, F , symmetrically placed on the other side of the lens.

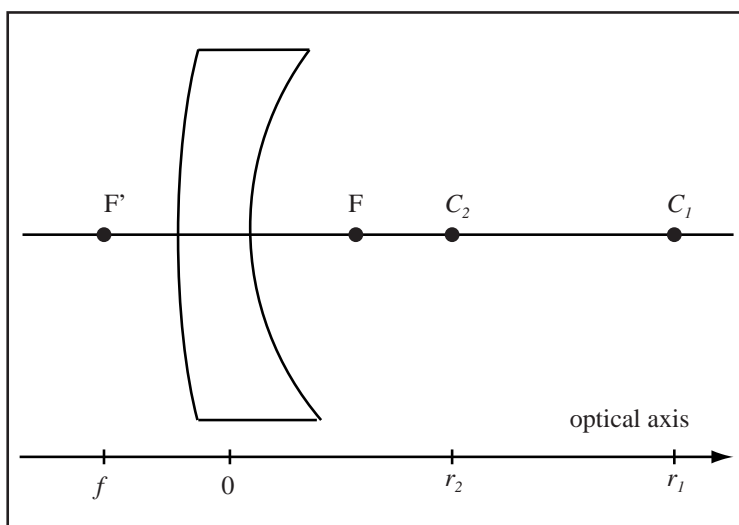

40.2.2 Focal Point for Convex and Concave Lenses

A converging lens system brings parallel rays together at a point and a diverging lens system brings the lines of apparent direction (the dashed lines) together at a point. This point is the secondary focal point, F' , of the system.

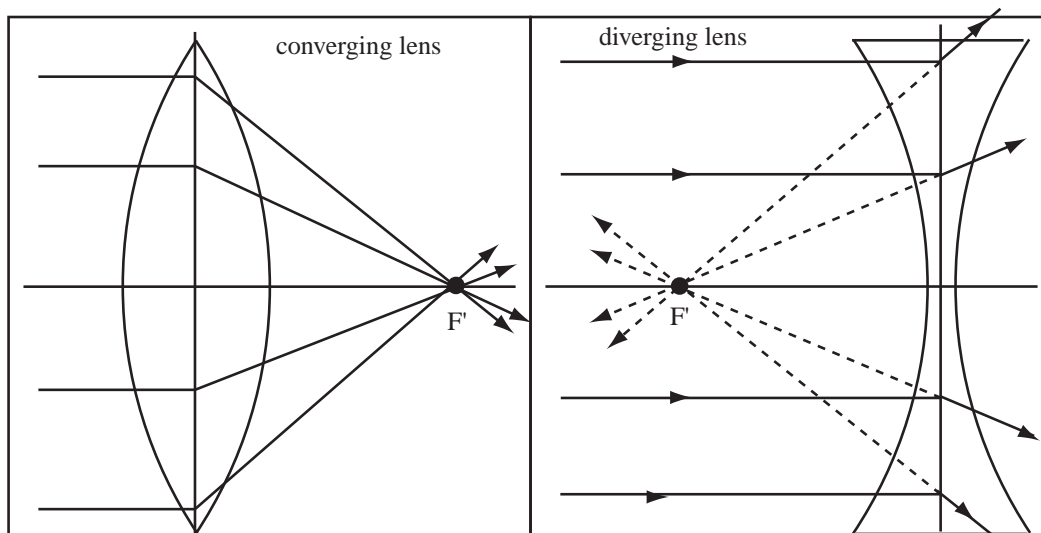

Optical systems work backwards. If we place a point light source at the primary focal point of a converging lens system, parallel rays will exit the system. This is how the ray boxes in lab work. If light is shone toward the primary focal point of a diverging lens, parallel light rays exits the system.

Primary Focal Point of a Lens

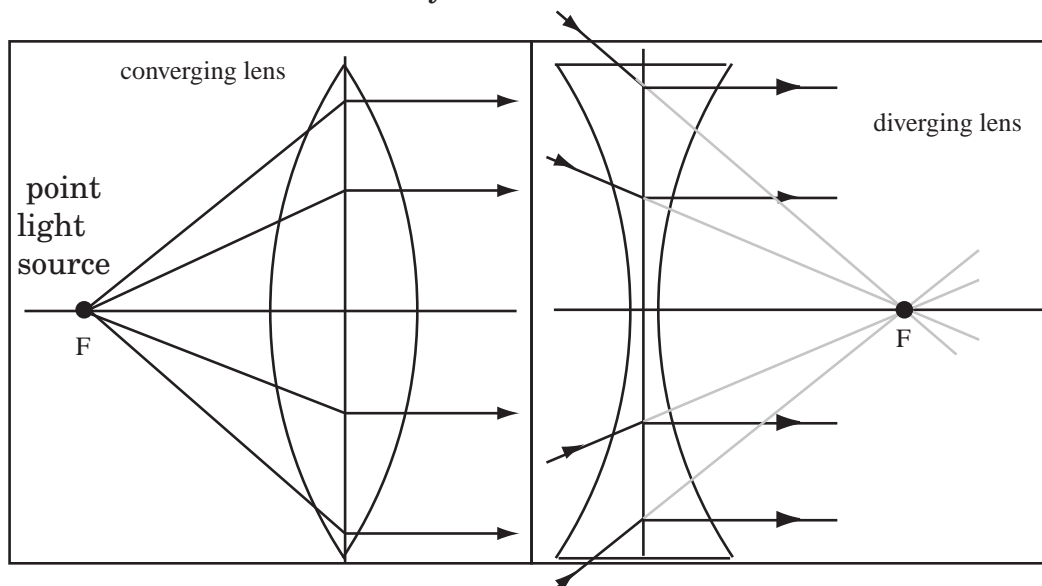

40.2.3 Ray Tracing for Thin Lenses

To draw the ray diagram for a thin lens, do the following:

- Draw the lens with correct direction of curvature.
- Draw and label the secondary focal point (F'). The secondary focal point is the location where incoming parallel light is focused to a point.
- Draw and label the primary focal point (F). The primary focal point is on the opposite side of the lens from the secondary focal point and the same distance from the lens.
- Indicate the positive direction on the optical axis.
- Draw the location of the points s and f on the optical axis. Indicate using > 0 and < 0 whether these quantities are positive or negative.
- Draw the Parallel Ray and label it (P). The parallel ray leaves the object parallel to the axis and is refracted through the secondary focal point.
- Draw the Focal Ray and label it (FF). The focal ray lies along the line passing through the primary focal point and the object. At the lens, the ray is refracted parallel to the optical axis.
- Draw the Central Ray and label it (CC). The central ray travels straight through the center of the lens.
- Draw the Apparent Directions. For each ray, draw the apparent direction—the direction the *outgoing* ray appears to come from. Draw the apparent direction as a dashed line.

This will be illustrated by the examples which follow. If you need more detail on drawing the ray diagram of either a lens or mirror consult the next chapter.

40.2.4 Computing and Describing the Image Location of a Thin Lens

The location of images for thin lenses and the magnification of systems containing thin lenses are found with the same equations as spherical mirrors. The differences disappeared in our sign convention and the computation of the focal length.

Thin-Lens Equation : The location of an image, s' , formed by a thin lens is given by the thin-lens equation

$$\frac{1}{s} + \frac{1}{s'} = \frac{1}{f}$$

where f is the focal length and s is the object distance.

Lateral Magnification of an Image Formed Through a Thin Lens : The lateral magnification, m , of a thin lens is

$$m = -\frac{s'}{s}$$

Example 40.6 Virtual Image from Convex Lens

Problem: A convex lens has a focal length of magnitude $|f| = 6\text{cm}$. An object is placed 2.5cm from the lens. The dark lines on the grid below each represent 1cm .

- Draw the ray diagram and locate the image. Label the location of the primary and secondary focal points.
- Indicate the positive direction on the optical axis. Mark important locations on the optical axis.
- From your ray diagram, what is the magnification and image location? Make sure to report both with the correct sign.
- Describe the image based on your ray diagram.
- Compute the image location using the thin lens equation.
- Compute the magnification.
- Describe the image based on your computation. Tell why your calculation supports your description of the image.

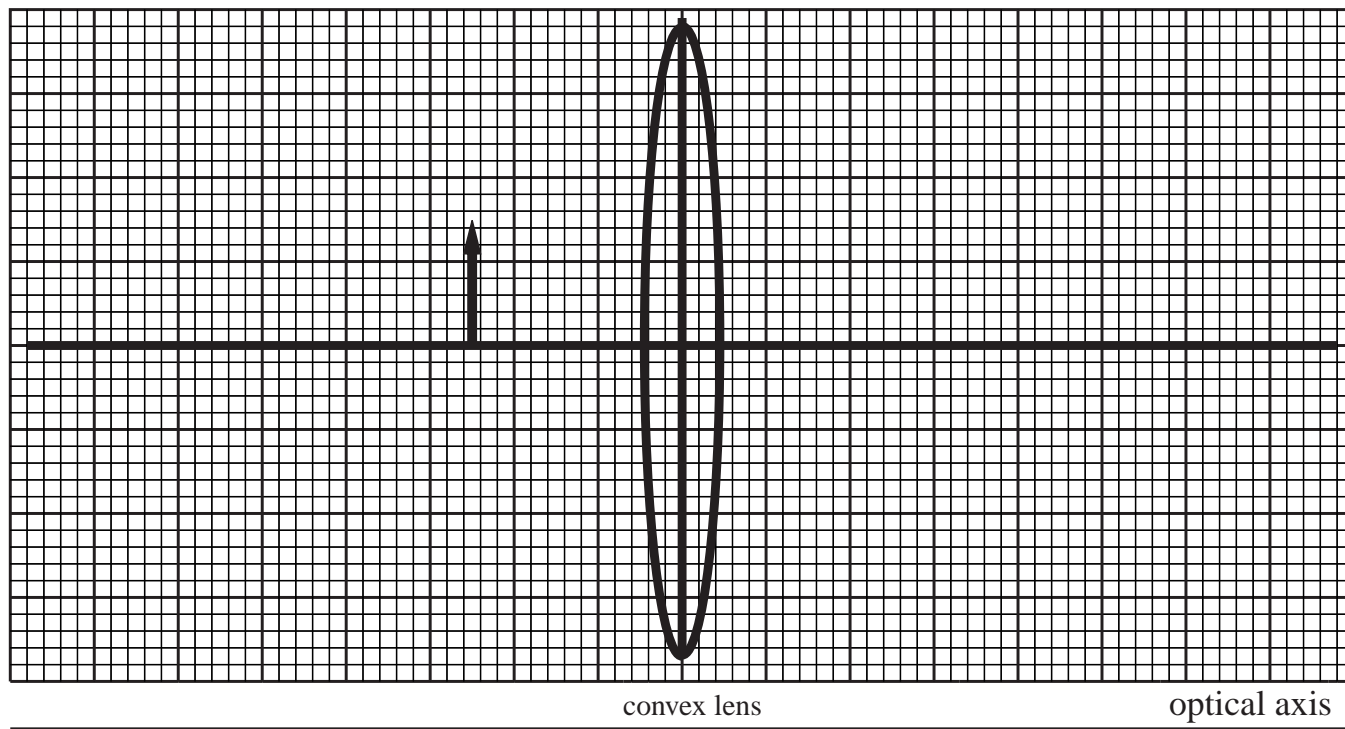

Solution to Part(a)

The central ray is drawn from the object through the center of the lens. The parallel ray is drawn from the object parallel to the axis and is refracted so that it passes through the secondary focal point. The focal ray is drawn as if it comes from the primary focal point and is refracted parallel to the axis at the lens.

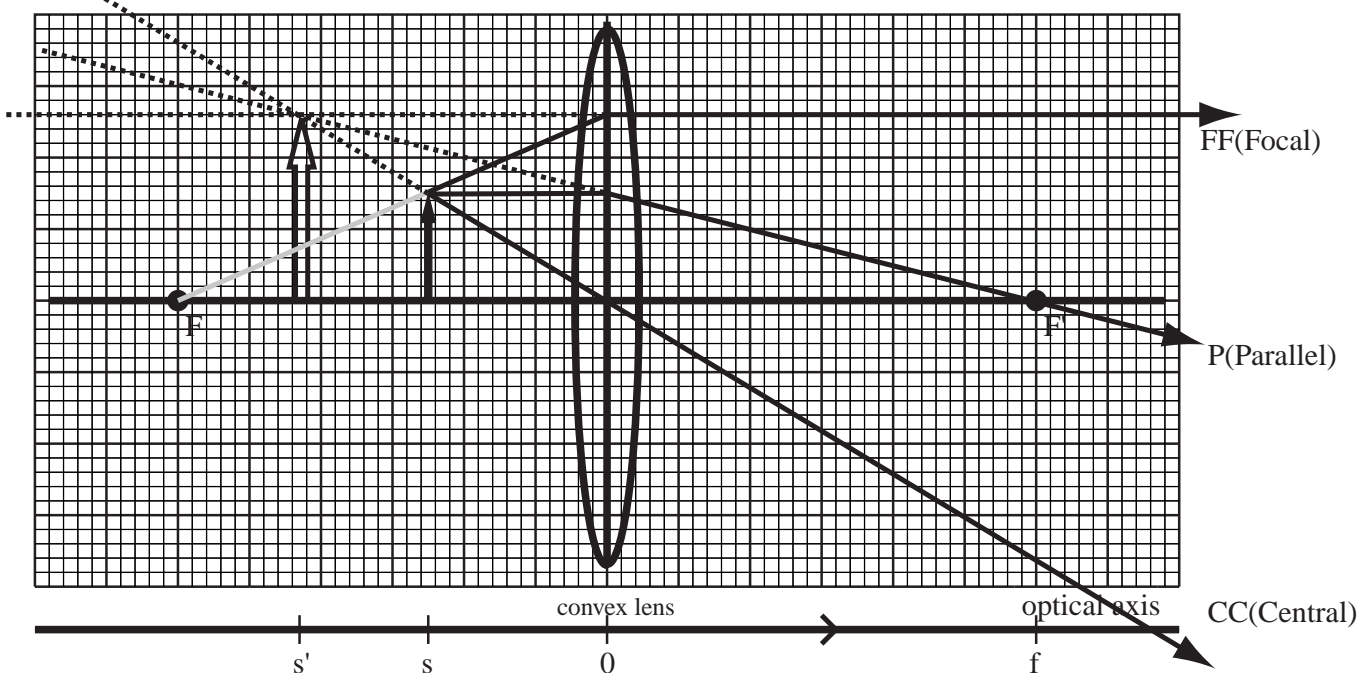

Solution to Part(b)

The optical axis is positive to the right, because that is the transmitted direction. Since the lens is convex, the focal length is positive. Draw f at the appropriate point on the axis. Above f , draw the secondary focal point, F' . Draw the primary focal point F at an equal distance from the lens on the opposite side of the lens. Mark the location of the object s , the image s' , and the lens 0 on the optical axis.

Solution to Part(c)

The image is 2.6cm tall and the object is 1.5cm tall, giving a magnification of $m=2.6\text{cm}/1.5\text{cm} = 1.7$. The magnification is positive, because the image is upright. The image location is -4.3cm .

Solution to Part(d)

The image is upright (not flipped over), enlarged (it is taller), and virtual (it is formed of the apparent directions of the light).

Solution to Part(e)

The Thin Lens Equation is

$$\frac{1}{f} = \frac{1}{s} + \frac{1}{s'}$$

For this system, $f = +6\text{cm}$ and $s = 2.5\text{cm}$. Substitute,

$$\frac{1}{6\text{cm}} = \frac{1}{2.5\text{cm}} + \frac{1}{s'}$$

Solving for the image distance, $s' = -4.29\text{cm}$.

Solution to Part(f)

The magnification is given by

$$m = -\frac{s'}{s} = -\frac{(-4.29\text{cm})}{2.5\text{cm}} = 1.71.$$

Solution to Part(g)

The image is virtual ($s' < 0$), upright ($m > 0$), and enlarged ($|m| > 1$).

Example 40.7 Locate and Interpret the Image Formed by a Thin Concave Lens

Problem: An object (upright arrow) is 50.0cm from a diverging lens with a focal length with magnitude of 20.0cm. Using graphical and mathematical techniques, locate and interpret the image.

Solution

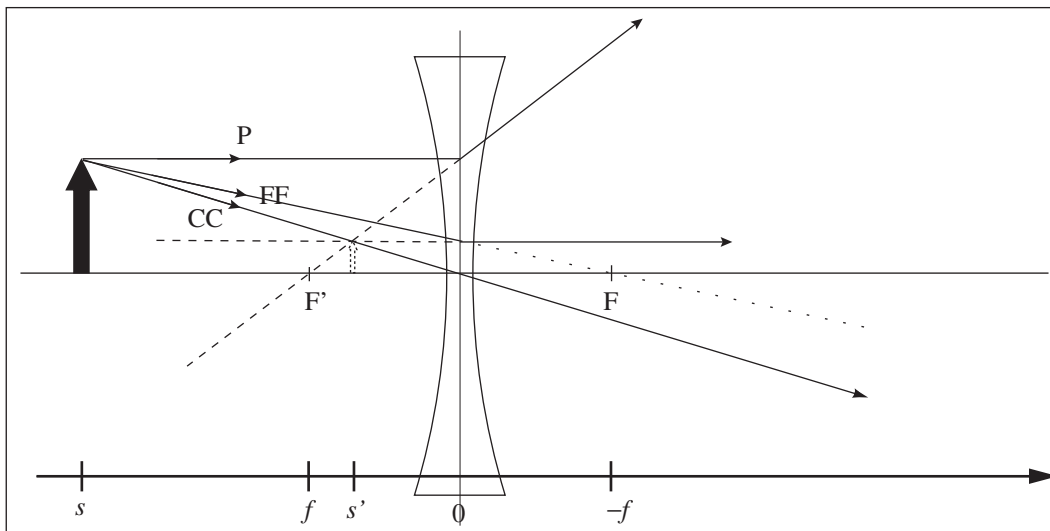

Definitions

- $s = 50.0\text{cm} \equiv$ Distance of object from the lens' centerline
 $s' \equiv$ Distance of image from the lens' centerline
 $m \equiv$ Lateral magnification of the object
 $f = -20.0\text{cm} \equiv$ Focal length for the *diverging* lens
 $F \equiv$ Primary focal point for the lens
 $F' \equiv$ Secondary focal point for the lens

(a) Draw all Possible Principal Rays: Central, Focal, and Parallel rays. Draw the situation to scale as in the figure above.

(b) Interpret the Image: From the ray diagram, extrapolate the image and compare it to the object for magnification and determine whether it is upright or inverted, reduced or enlarged, and a real or virtual image. For each characteristic, give the corresponding mathematical (qualitative) interpretation. This is a virtual $s' < 0$, reduced $|m| < 1$, upright $m > 0$ image.

(c) Compute the Image Distance: Use the thin-lens equation,

$$\frac{1}{s} + \frac{1}{s'} = \frac{1}{f},$$

to solve for the image distance. The image distance is

$$s' = \left(\frac{1}{f} - \frac{1}{s} \right)^{-1} = \left(\frac{1}{-20.0\text{cm}} - \frac{1}{50.0\text{cm}} \right)^{-1} = -14.3\text{cm}$$

The image distance is negative, which means a virtual image. This corresponds to the results obtained by the graphical technique.

(d) Compute the Magnification of the Image: The magnification is found by using $m = -s'/s$. The magnification is

$$m = \frac{-s'}{s} = -\frac{-14.3\text{cm}}{50.0\text{cm}} = +0.286$$

Since this number is positive, the image is upright. Since it is less than one, the image is reduced. These correspond to the results obtained by the graphical technique.

Chapter 41

Ray Diagram Reference

This chapter is a very detailed reference to the tracing of rays through systems of thin lenses and mirrors. It should be used as a reference and consulted when the material of the previous chapter was not enough. An additional example is provided for each type of optical element.

41.1 Ray Tracing for Concave Mirrors

To trace the rays as they reflect off of a concave mirror to form an image, we use four principle rays: (1) the Parallel Ray, (2) the Central Ray, (3) the Focal Ray, and (4) the Radial Ray. We will approximate the mirror as having a large radius of curvature, so that the rays bend at the plane through the point zero and not at the mirror's surface. This is the approximation made in the equations we use to locate the image later this section. In all cases which follow, the object whose image we wish to locate is represented by a solid black arrow. The location of the object is labelled, s , on the optical axis.

Locate Landmarks for Concave Mirrors and Use Sign Convention : The center of curvature C for the mirror is located a distance r from the mirror. The focal point f is located a distance $r/2 \equiv f$ from the mirror. The sign convention, as applied to the figure below is that since both r and f are on the transmitted side of the mirror, $r > 0$ and $f > 0$.

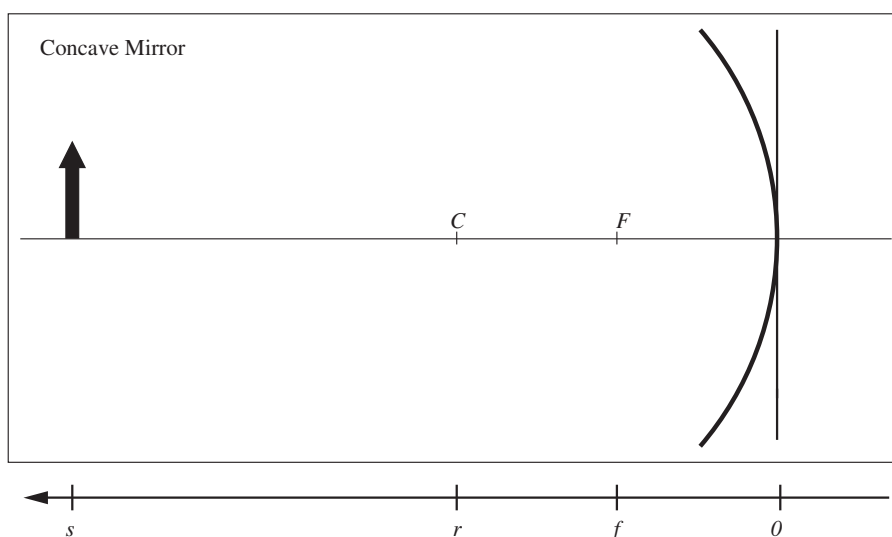

Draw the Parallel Ray for a Concave Mirror : Incoming light rays that are parallel to the axis are reflected through the focal point.

- **Draw the incoming ray** Choose a point on the object (object point) to analyze. Draw a solid line (with arrow) that is parallel to the axis from this object point to the mirror (mirror point).
- **Draw the line of sight** Draw a faint line *through* the mirror point and the focal point. The focal point is in front of the mirror.
- **Draw the outgoing (reflected) ray** Draw a solid line (with arrow) along the line of sight back from the mirror point.
- **Draw the apparent source direction** Draw a dashed line along the line of sight, from the mirror point away from the reflected ray.

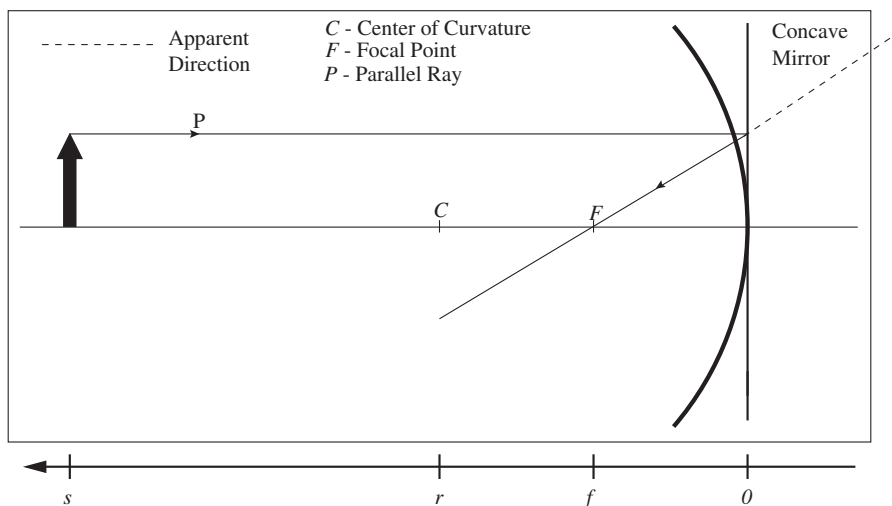

Draw the Central Ray for a Concave Mirror : Incoming light rays that strike the mirror at its vertex are reflected away at the same angle according to the law of reflection, since the angle from the axis is the angle from the normal at this point.

- **Draw the incoming ray** Choose a point on the object (object point) to analyze. Draw a solid line (with arrow) from the object point to the vertex of the mirror (mirror point).
- **Draw the outgoing (reflected) ray** Draw a solid line (with arrow) along the line of sight back from the mirror point.
- **Draw the apparent source direction** Draw a dashed line behind the mirror point in the same direction as the reflected ray.

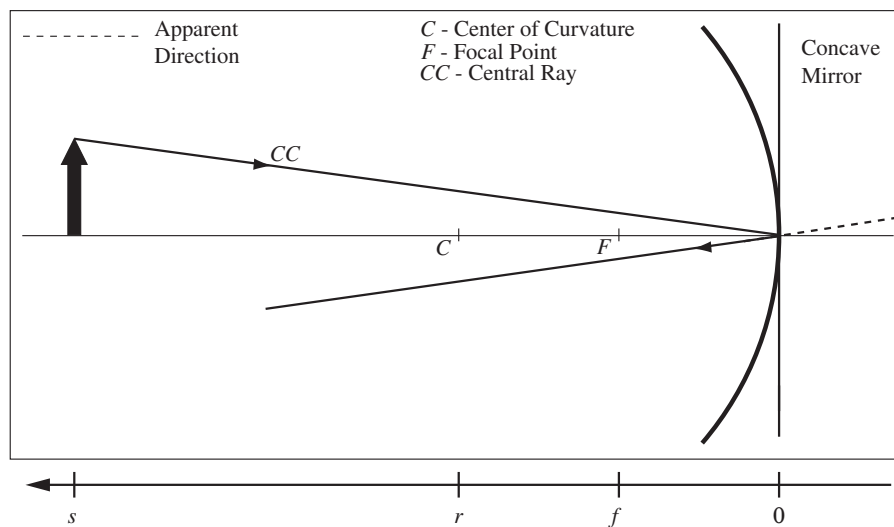

Draw the Focal Ray for a Concave Mirror : Incoming light rays that go through the focal point are reflected parallel to the axis.

- **Draw the incoming ray** Using the guide line, draw a solid line (with arrow) from the object point to the mirror point, passing through the focal point.
- **Draw the line of sight** Draw a faint line parallel to the axis, which extends *through* the mirror point.
- **Draw the outgoing (reflected) ray** Draw a solid line (with arrow) along the line of sight back from the mirror point.
- **Draw the apparent source direction** Draw a dashed line along the line of sight, from the mirror point away from the reflected ray.

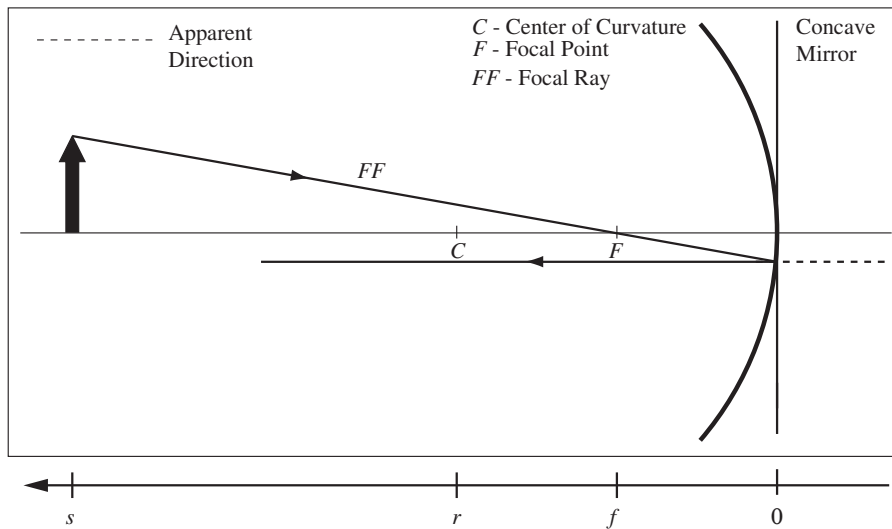

Draw the Radial Ray for a Concave Mirror : Incoming light rays that go through the center of curvature are reflected directly back along the same line, since $\theta_i = 0$ for this case.

- **Draw the incoming ray** Using the guide line, draw a solid line (with arrow) from the object point to the mirror point, passing through the center of curvature (C).
- **Draw the line of sight** For the radial ray, which reflects back on itself, the ray is the line of sight.
- **Draw the outgoing (reflected) ray** Draw an arrow along the line of sight back from the mirror point.
- **Draw the apparent source direction** Draw a dashed line along the line of sight, from the mirror point away from the reflected ray.

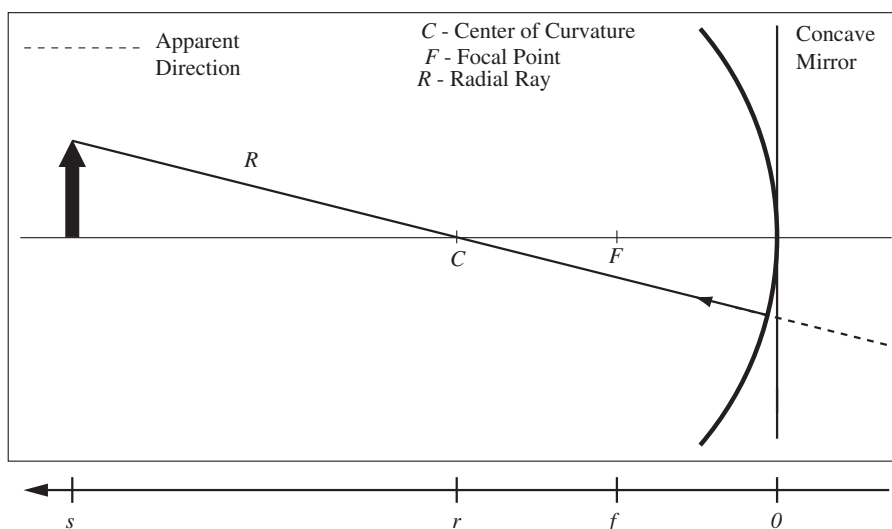

Put it All Together to Form an Image: There will be a point where either the reflected rays or the apparent directions of the reflected rays intersect at a point. This is the image. We draw another arrow to represent the image.

The location of the image is indicated with an s' on the optical axis. The example which follows shows how to use ray tracing to locate and describe the image.

Example 41.1 Draw a Ray Diagram for a Concave Mirror

Problem: Given the object and mirror below, where C is the center of curvature and the object is a distance $s = 1\text{m}$ from the vertex of the mirror, draw a ray diagram and label the locations s' and f . Graphically compute the image distance, s' , and the magnification, m .

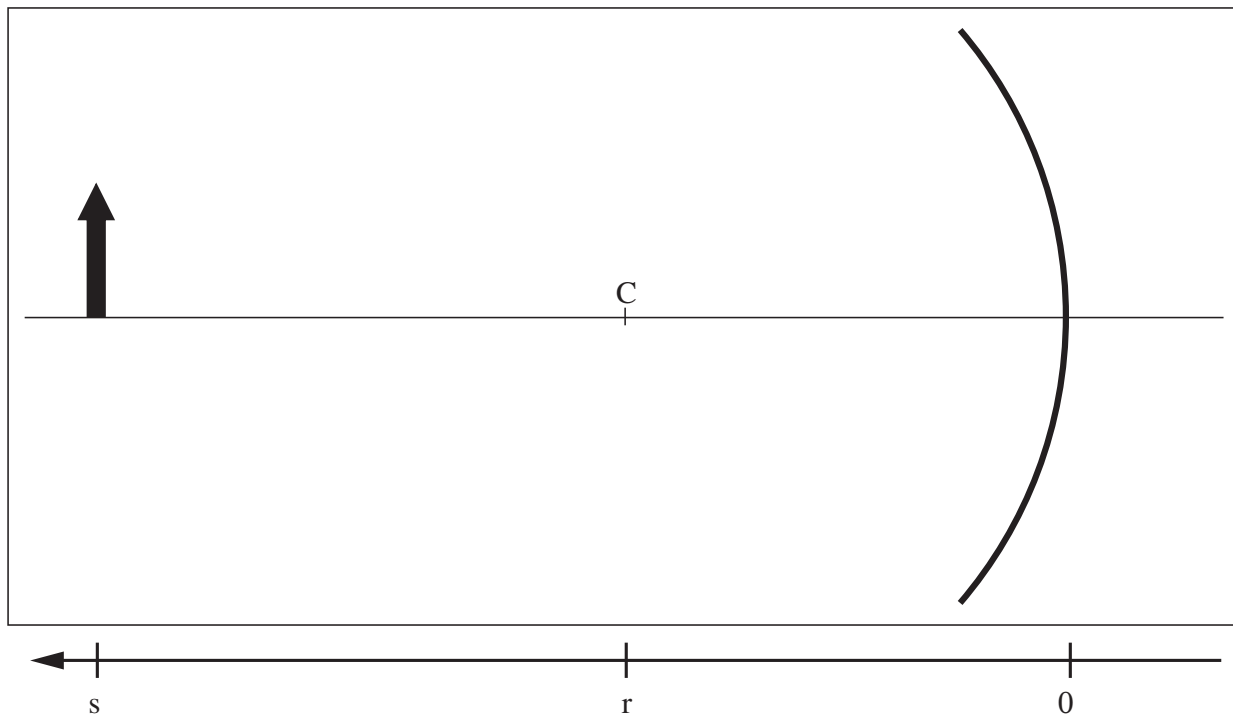

Solution

First, we location the focal point which is half the distance to the lens from the center of curvature. Draw all possible principal rays for an object point: central, radial, focal, and parallel rays. The rays intersect at a point where the image is formed. Draw in the image. Measure the image distance and adjust for the scale. I get $s_{scale} = 12\text{cm}$ and $s'_{scale} \approx 3.5\text{cm}$ by measuring the figure with a ruler. Since we are given $s = 1\text{m}$, then $s' \approx (3.5\text{cm}) \frac{1\text{m}}{12\text{cm}} = 30\text{cm}$. Compute the magnification as image height, 0.5cm , divided by object height, 1.7cm , as measured from the image below. $m \approx -0.5\text{cm}/1.7\text{cm} = -0.3$. The $-$ enters because the image is inverted.

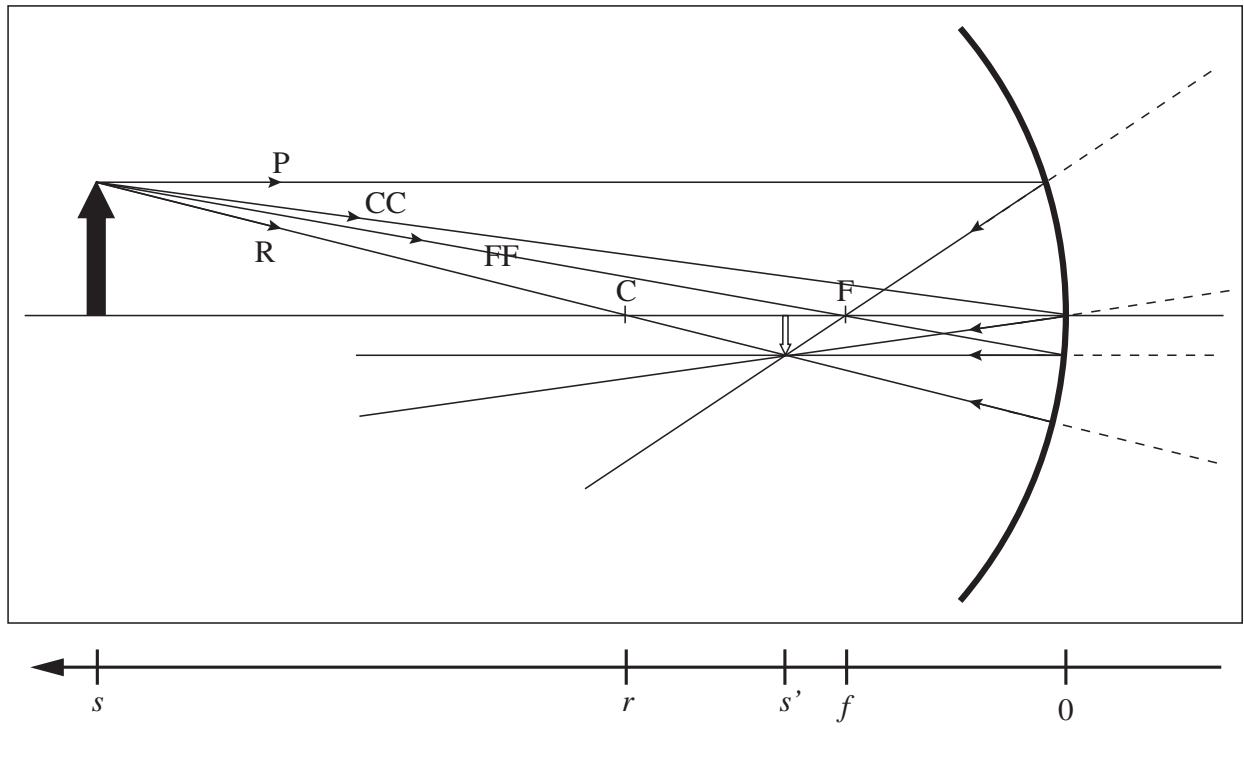

41.2 Ray Tracing for Convex Mirrors

The same general process is followed for drawing the ray diagram for a convex mirror, except now the focal point is behind the mirror.

Locate Landmarks for Convex Mirrors and Use Sign Convention : The center of curvature C for the mirror is located a distance r from the mirror. The focal point F is located a distance $r/2 \equiv F$ from the mirror. The sign convention is as applied to the figure at the right. Since both r and f are not on the transmitted side of the mirror, $r < 0$ and $f < 0$.

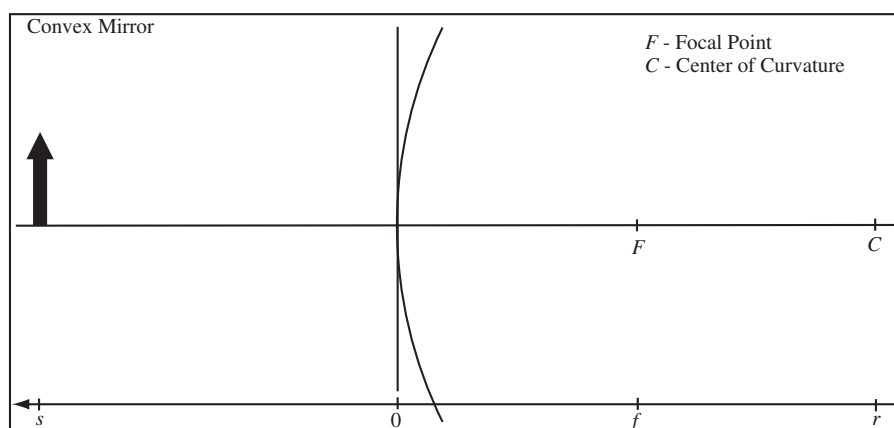

Draw the Parallel Ray for a Convex Mirror : Incoming light rays that are parallel to the axis are reflected “through” the focal point.

- **Draw the incoming ray** Choose a point on the object (object point) to analyze. Draw a solid line (with arrow) that is parallel to the axis from this object point to the mirror (mirror point).
- **Draw the line of sight** Draw a faint line *through* the mirror point and the focal point. The focal point will be behind the mirror.
- **Draw the outgoing (reflected) ray** Draw a solid line (with arrow) along the line of sight back from the mirror point.
- **Draw the apparent source direction** Draw a dashed line along the line of sight, from the mirror point away from the reflected ray.

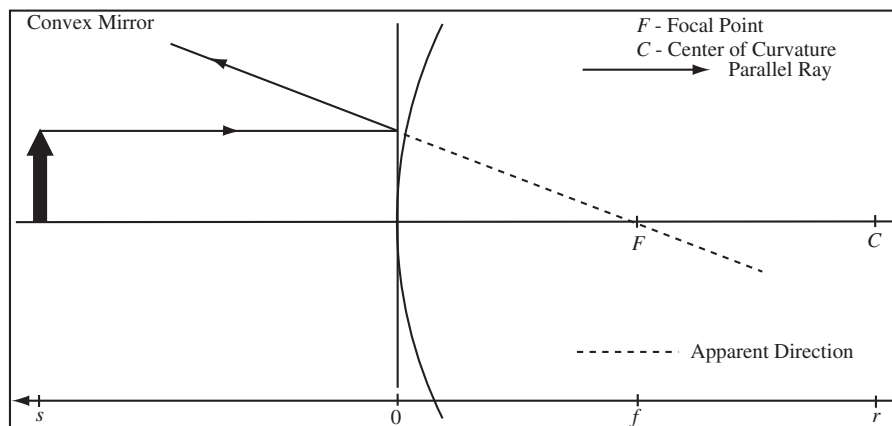

Draw the Central Ray for a Convex Mirror : Incoming light rays that strike the mirror at its vertex are reflected away at the same angle according to the law of reflection.

- **Draw the incoming ray** Choose a point on the object (object point) to analyze. Draw a solid line (with arrow) from the object point to the vertex of the mirror (mirror point).
- **Draw the outgoing (reflected) ray** Draw a solid line (with arrow) along the line of sight back from the mirror point.
- **Draw the apparent source direction** Draw a dashed line behind the mirror point in the same direction as the reflected ray.

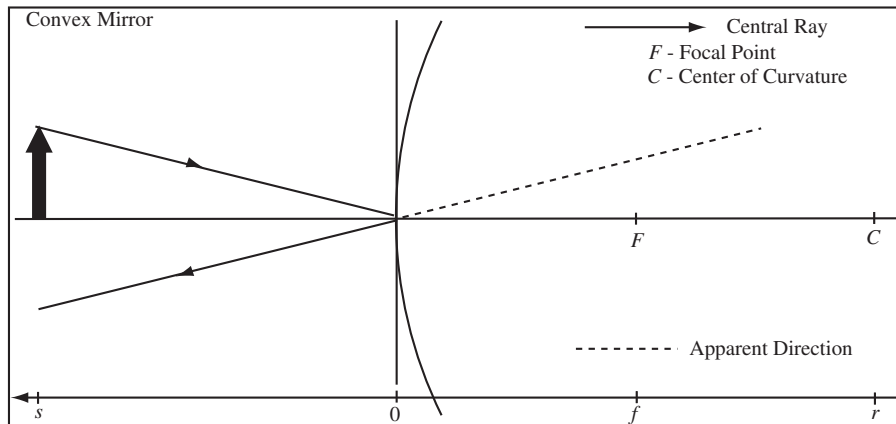

Draw the Focal Ray for a Convex Mirror : Incoming light rays that go “through” the focal point are reflected parallel to the axis.

- **Draw a guide line** Choose a point on the object (object point) to analyze. Draw a faint line through the object point and the focal point, F .
- **Draw the incoming ray** Using the guide line, draw a solid line (with arrow) from the object point to the mirror point.
- **Draw the line of sight** Draw a faint line parallel to the axis, which extends *through* the mirror point.
- **Draw the outgoing (reflected) ray** Draw a solid line (with arrow) along the line of sight back from the mirror point.
- **Draw the apparent source direction** Draw a dashed line along the line of sight, from the mirror point away from the reflected ray.

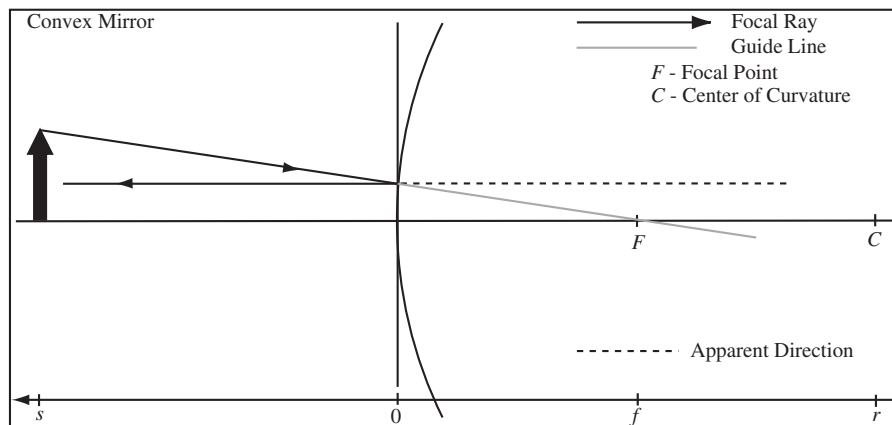

Draw the Radial Ray for a Convex Mirror : Incoming light rays that go “through” the center of curvature are reflected directly back along the same line, since $\theta_i = 0$ for this case.

- **Draw a guide line** Choose a point on the object (object point) to analyze. Draw a faint line through the object point and the center of curvature, C .
- **Draw the incoming ray** Using the guide line, draw a solid line (with arrow) from the object point to the mirror point.
- **Draw the line of sight** The faint line from the mirror point to the center of curvature, C , is the line of sight.
- **Draw the outgoing (reflected) ray** Draw a solid line (with arrow) along the line of sight back from the mirror point.
- **Draw the apparent source direction** Draw a dashed line along the line of sight, from the mirror point away from the reflected ray.

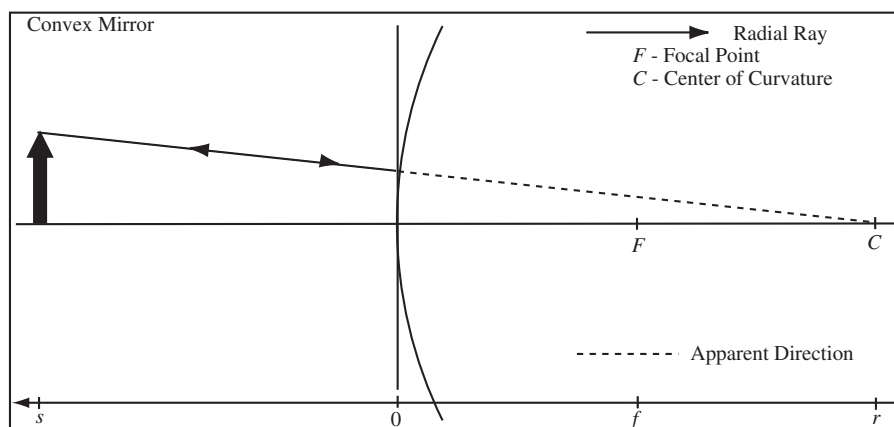

Put it All Together to Form an Image: There will be a point where either the reflected rays or the apparent directions of the reflected rays intersect at a point. This is the image.

The following example illustrates how to use ray tracing to locate and describe an image for a convex mirror.

Example 41.2 Ray Diagram for a Convex Mirror

Problem: A convex spherical mirror has a focal length of magnitude 4cm. Draw a ray diagram for an object located 2cm from the vertex. Interpret the image formed.

Solution

Draw your diagram, carefully getting the focal length, radius or curvature, and the object distance to scale. Draw your optical coordinate axis and label all these quantities. Draw an object on the diagram of a height which makes the ray drawing convenient. Draw the four principle rays and their apparent directions. The place where either the reflected rays or their apparent directions cross is the image. Draw an image at the place the rays cross. Now, describe the image. The image below has the same orientation as the object and is therefore upright. The image is smaller than the object and is therefore reduced. The image is formed by the apparent direction of the reflected rays, so it is virtual. By measuring the image and the object height, we can report a magnification of the image as

$$m = \frac{\text{Image Height}}{\text{Object Height}} = \frac{1.33\text{cm}}{2\text{cm}} = 0.67$$

where I have measured the image and object height with a rule. Depending on your printer, your diagram may be re-scaled but you should get the same ratio.

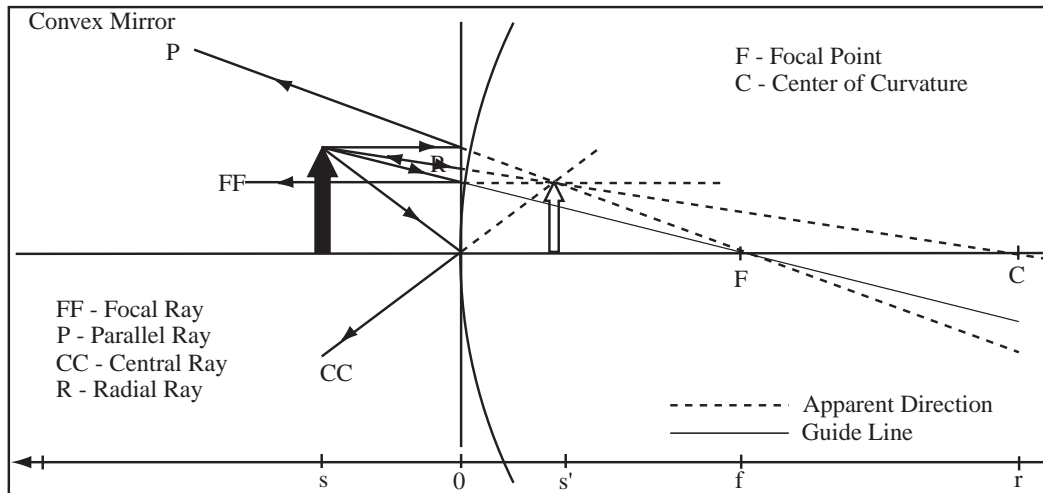

41.3 Ray Tracing for Convex Lenses

The simplicity of the spherical geometry allows for ray diagrams to be used to locate an image. There are three principal rays which can be drawn: (1) Parallel, (2) Central, and (3) Focal. In all of the following diagrams, the axis at the bottom shows

- the location of the lens' center 0
- the object distance s
- the image distance s'
- the focal length f
- and the general direction of the light after refraction (arrowhead direction)

Locate Landmarks for Converging Lens : A convex lens has two interfaces, the centers of curvature (C_1 and C_2) are located $r_1 > 0$ and $r_2 < 0$ from their respective interfaces. The focal points (F and F') are located a focal length, f , from the centerline of the lens.

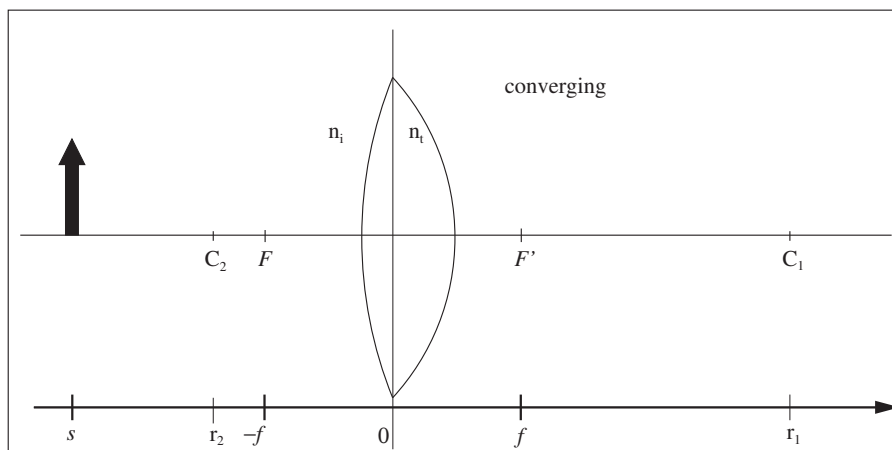

Draw the Parallel Ray for a Converging Lens : Incoming rays that are parallel to the axis are refracted “through” the secondary focal point, F' .

- **Draw the incoming ray** Choose a point on the object (object point) to analyze. Draw a solid line (with arrow) that is parallel to the axis from this object point to the centerline of the lens (lens point).
- **Draw the line of sight** Draw a faint line *through* the lens point and the secondary focal point.
- **Draw the outgoing (refracted) ray** Draw a solid line (with arrow) along the line of sight that starts at the lens point and extends away from the object.
- **Draw the apparent source direction** Draw a dashed line along the line of sight, which extends the outgoing ray in the opposite direction.

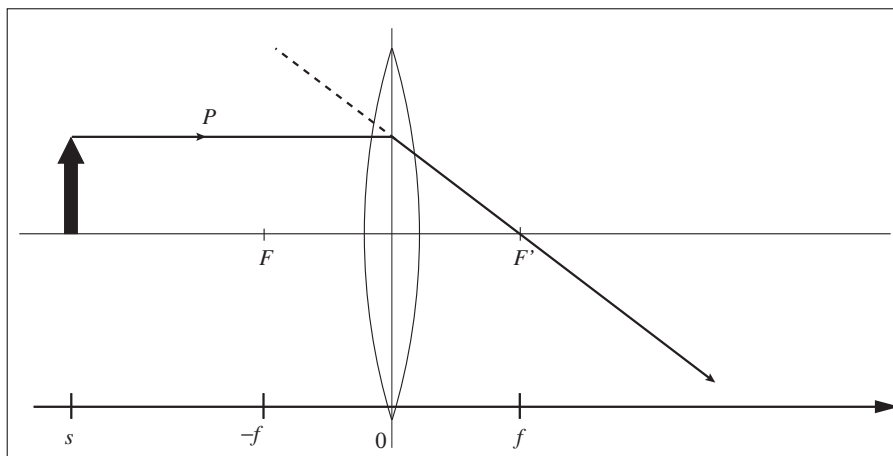

Draw the Central Ray for a Converging Lens : Incoming rays which go through the center of the lens are undeflected. Draw a solid line (with arrow) from the object point *through* the center of the lens.

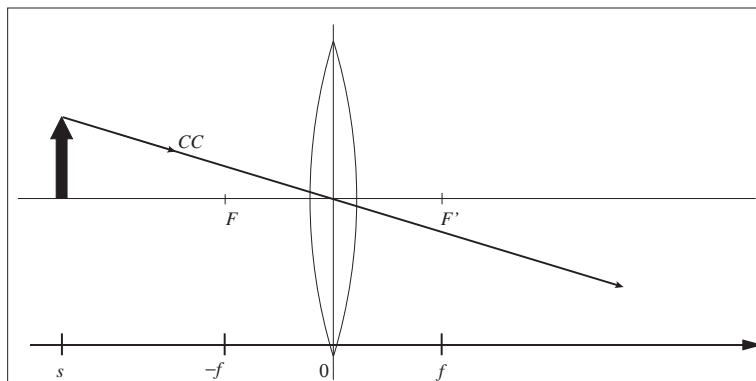

Draw the Focal Ray for a Converging Lens : Incoming rays which go “through” the primary focal point, F , are refracted parallel to the axis.

- **Draw a guide line** Choose a point on the object (object point) to analyze. Draw a faint line through the object point and the primary focal point, F , taking care to extend the line to a point on the lens (lens point).
- **Draw the incoming ray** Using the guide line, draw a solid line (with arrow) from the object point to the lens point.
- **Draw the line of sight** Draw a faint line parallel to the axis which extends *through* the lens point.
- **Draw the outgoing (refracted) ray** Draw a solid line (with arrow) along the line of sight from the lens point away from the object.
- **Draw the apparent source direction** Draw a dashed line along the line of sight, from the lens point towards the object.

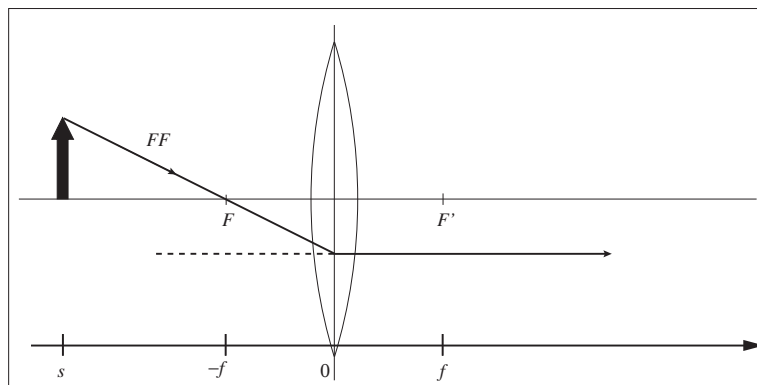

41.4 Ray Tracing for Concave Lenses

There are three principal rays which can be drawn: (1) Parallel, (2) Central, and (3) Focal. In all of the following diagrams, the axis at the bottom shows

- the location of the lens' center 0
- the object distance s
- the image distance s'
- the focal length f
- and the general direction of the light after refraction (arrowhead direction)

Locate Landmarks for a Diverging Lens: A concave lens has two interfaces, the centers of curvature (C_1 and C_2) are located $r_1 < 0$ and $r_2 > 0$ from their respective interfaces. The secondary focal point F' is located a focal length, f , from the centerline of the lens. The primary focal point is located a distance $-f$ from the center of the lens.

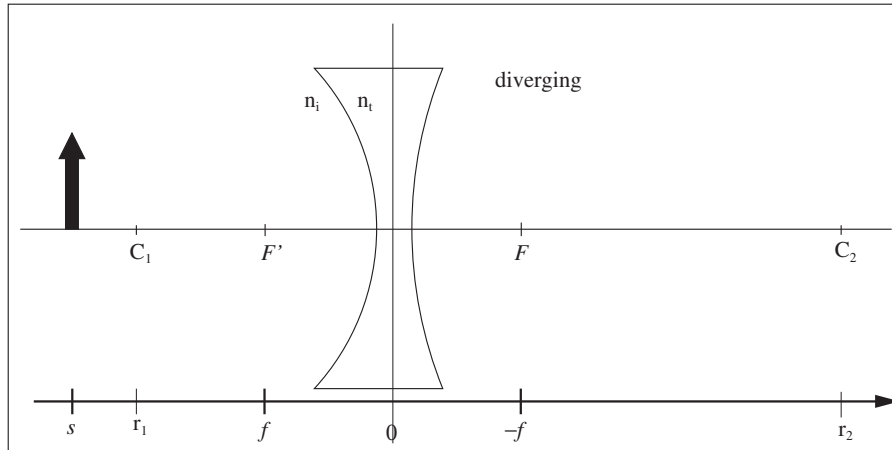

Draw the Parallel Ray for a Diverging Lens: Incoming rays that are parallel to the axis are refracted "through" the secondary focal point, F' .

- **Draw the incoming ray** Choose a point on the object (object point) to analyze. Draw a solid line (with arrow) that is parallel to the axis from this object point to the centerline of the lens (lens point).
- **Draw the line of sight** Draw a faint line *through* the lens point and the secondary focal point.
- **Draw the outgoing (refracted) ray** Draw a solid line (with arrow) along the line of sight that starts at the lens point and extends away from the object.
- **Draw the apparent source direction** Draw a dashed line along the line of sight, which extends the outgoing ray in the opposite direction.

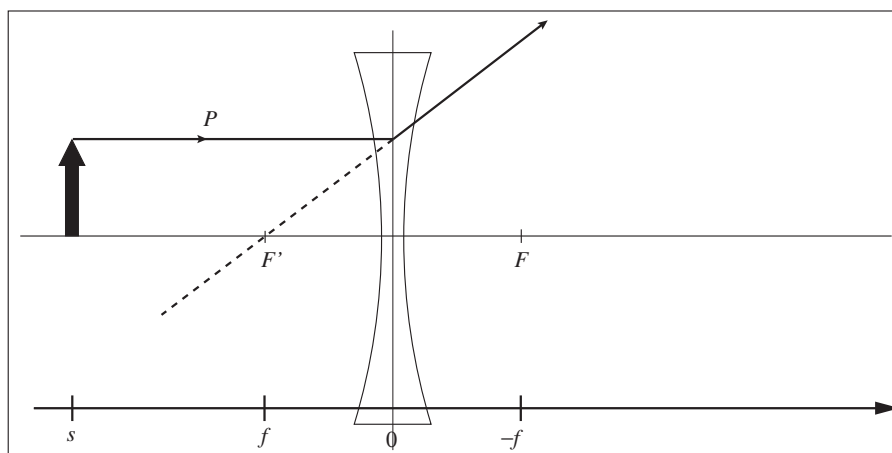

Draw the Central Ray for a Diverging Lens: Incoming rays which go through the center of the lens are undeflected. Draw a solid line (with arrow) from the object point *through* the center of the lens.

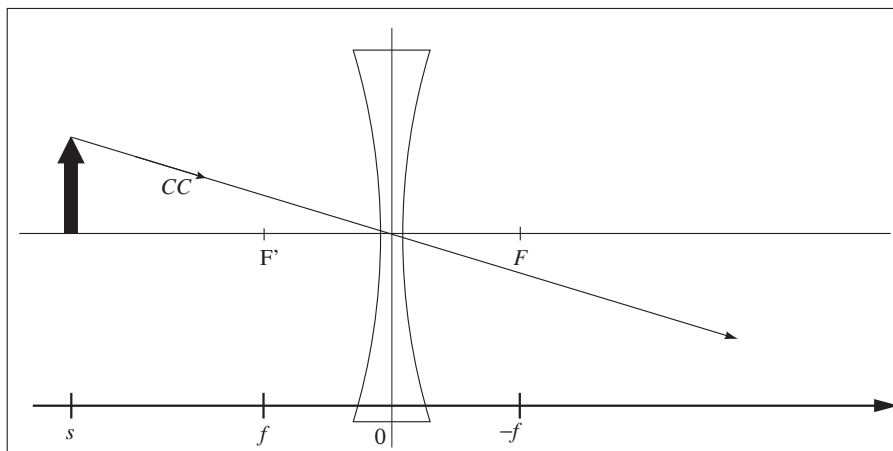

Draw the Focal Ray for a Diverging Lens: Incoming rays which go “through” the primary focal point, F , are refracted parallel to the axis.

- **Draw a guide line** Choose a point on the object (object point) to analyze. Draw a faint line through the object point and the primary focal point, F .
- **Draw the incoming ray** Using the guide line, draw a solid line (with arrow) from the object point to the lens point.
- **Draw the line of sight** Draw a faint line parallel to the axis which extends *through* the lens point.
- **Draw the outgoing (refracted) ray** Draw a solid line (with arrow) along the line of sight from the lens point away from the object.
- **Draw the apparent source direction** Draw a dashed line along the line of sight, from the lens point towards the object.

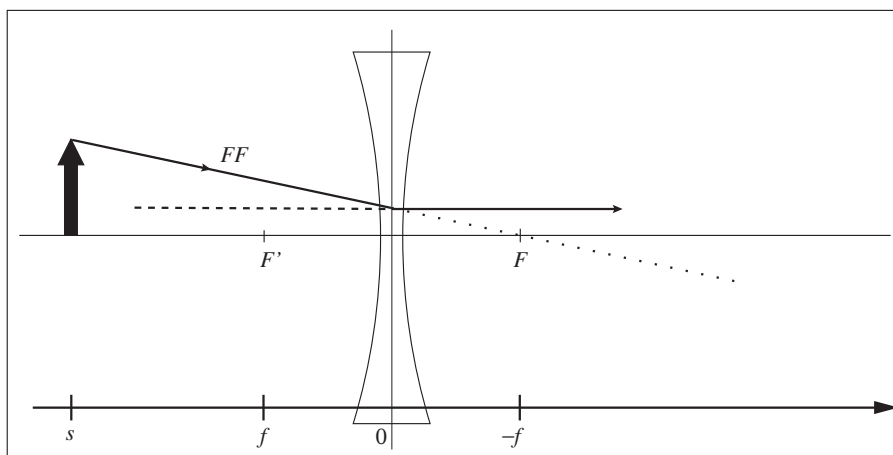

Chapter 42

Optical Systems

Our final chapter investigates the human eye as an optical detector and some common instruments used to enlarge objects for human viewing.

42.1 Optical Systems

42.1.1 Optical Systems Containing More than One Element

No additional physics is required to handle multiple lens/mirror systems. For each object the light reaches, apply the lens or mirror equation with the image of one element becoming the object of the next element. The magnification of the complete system is found as follows:

Magnification of Multiple Elements: The magnification, m , of an optical system containing multiple elements is found by multiplying the magnification of each individual element.

$$m = m_1 m_2 \dots m_N$$

Example 42.1 Compute the Image Distance Formed by Two Optical Elements (Mirrors and Lenses)

Problem: An object is 4.0cm from the center of a converging lens with a focal length of 3.0cm. It is in front of a concave mirror with a focal length of 1.875cm. The lens and the mirror are separated by 15cm of air. Compute the final image distance from the mirror and the total magnification.

Solution

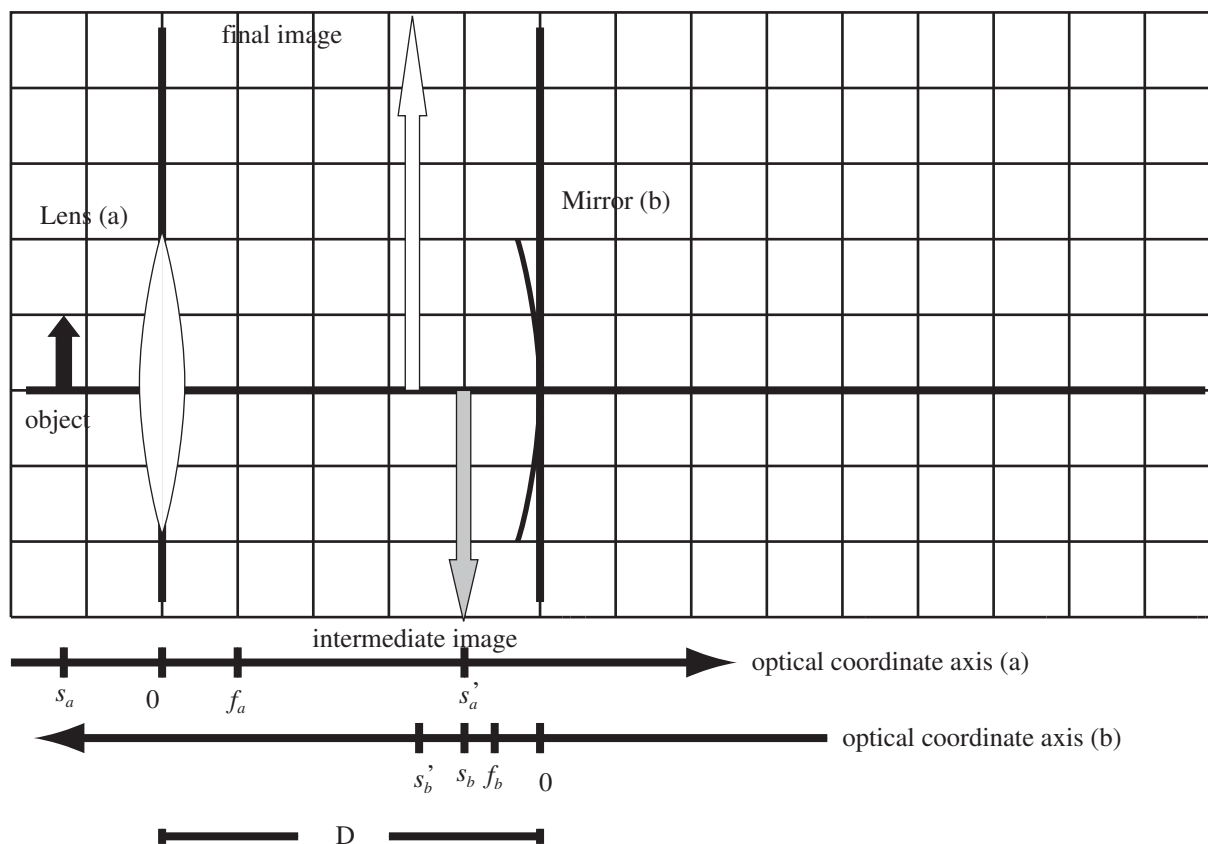

Definitions

- $s_a \equiv$ Distance of object from element a
- $s_b \equiv$ Distance of image from element b
- $s'_a \equiv$ Distance of intermediate image from element a
- $s'_b \equiv$ Distance of intermediate object from element b
- $f_a \equiv$ Focal length of element a
- $f_b \equiv$ Focal length of element b
- $D \equiv$ Separation between the optical elements

Strategy: Compute the intermediate image distance of the first lens and then use this as the object for the second lens.

(a) Draw the Optical System: Draw the real optical axis and the optical elements on the real optical axis. Draw the optical coordinate axis for both elements. The optical coordinate axis for a lens points to the right. The optical coordinate axis for the mirror points to the left. The axes have different origins, which are marked on each axis.

(b) Compute the Image Distance as Formed by Element a: Use Focal length version of the thin-lens equation. The intermediate image distance is, from the thin lens equation:

$$\frac{1}{s_a} + \frac{1}{s'_a} = \frac{1}{f_a}$$

$$s'_a = \left(\frac{1}{f_a} - \frac{1}{s_a} \right)^{-1} = \left(\frac{1}{3.0\text{cm}} - \frac{1}{4.0\text{cm}} \right)^{-1} = 12\text{cm}$$

(c) Compute the Magnification of Lens (a): The magnification is given by

$$m_a = -\frac{s'_a}{s_a} = -\frac{12\text{cm}}{4.0\text{cm}} = -3$$

(d) Calculate the Object Distance for Element b: The object distance for the mirror is

$$s_b = D - s'_a = 15\text{cm} - 12\text{cm} = 3.0\text{cm}$$

The intermediate image is drawn in gray and is between the lens and mirror.

(e) Compute the Image Distance as Formed by Element b: The focal length of the concave mirror is on the positive part of the mirror's optical axis. The image distance from the mirror found from the mirror equation is

$$\frac{1}{s_b} + \frac{1}{s'_b} = \frac{1}{f_b}$$

$$s'_b = \left(\frac{1}{f_b} - \frac{1}{s_b} \right)^{-1} = \left(\frac{1}{1.875\text{cm}} - \frac{1}{3.0\text{cm}} \right)^{-1} = 5\text{cm}$$

(f) Compute the Magnification of Mirror b: The magnification of element (b) is

$$m_b = -\frac{s'_b}{s_b} = -\frac{5\text{cm}}{3\text{cm}} = -1.67$$

(g) Compute the Total Magnification of the System: The total magnification is the product of the magnifications,

$$m_T = m_a m_b = (-3)(-1.67) = 5$$

The final image distance, s'_b , is positive, so the image is real. The magnification $|m_T| > 1$ so the object is enlarged and $m_T > 0$ for an upright image.

42.1.2 Virtual Objects

If our optical system only has one lens or mirror, then the convention that the object distance is always positive works just fine. When we have more than one optical element, the first element light reaches forms an intermediate image. This image becomes the object of the second element. The intermediate object can form on either the incident or transmitted side of the second element. It cannot be that the object distance is positive for both these cases. When the intermediate image forms on the transmitted side of second element, it becomes a *virtual object*, and has a negative object distance.

Virtual Object: A virtual object is an object formed as an intermediate image on the transmitted side of an optical element. A virtual object has a negative object distance.

The example which follows illustrates a system that forms a virtual object for the second lens.

Example 42.2 System with Virtual Objects

Problem: An object is a distance of 30cm from a convex lens with focal length 10cm. A second concave lens is a distance 12cm from the first lens and has focal length -4cm . Locate and describe the final image of the system.

Solution

(a) Compute the Intermediate Image: The thin lens equation locates the image of the first lens,

$$\frac{1}{f_1} = \frac{1}{s_1} + \frac{1}{s'_1} \quad \Rightarrow \quad \frac{1}{10\text{cm}} = \frac{1}{30\text{cm}} + \frac{1}{s'_1}$$

The intermediate image distance is $s'_1 = 15\text{cm}$. The magnification of the first lens is

$$m_1 = -\frac{s'_1}{s_1} = -\frac{15\text{cm}}{30\text{cm}} = -\frac{1}{2}$$

The image forms to the right, on the transmitted side, of the second lens. It forms a virtual object for this lens.

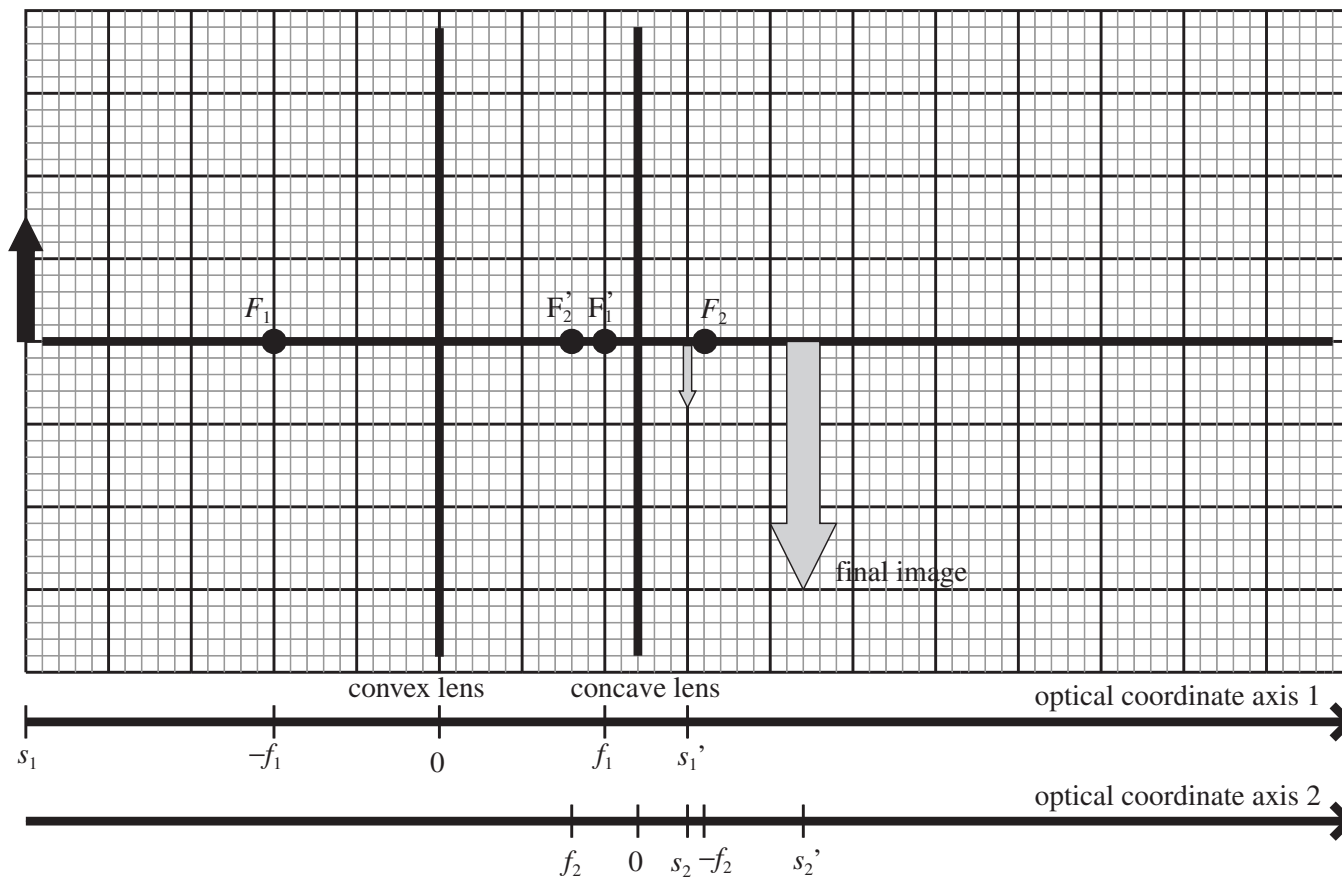

(b) Calculate the Object Distance for Lens 2: The object distance for the second lens is $s_2 = d - s_1' = 12\text{cm} - 15\text{cm} = -3\text{cm}$.

(c) Calculate the Final Image Location: The thin lens equation locates the image of the second lens,

$$\frac{1}{f_2} = \frac{1}{s_2} + \frac{1}{s_2'} \Rightarrow \frac{1}{-4\text{cm}} = \frac{1}{-3\text{cm}} + \frac{1}{s_2'}$$

The final image distance is $s_2' = 12\text{cm}$. The magnification of the second lens is

$$m_2 = -\frac{s_2'}{s_2} = -\frac{12\text{cm}}{-3\text{cm}} = +4$$

(d) Describe the Image: The total magnification is the product of the magnifications of the individual lenses, $m_T = m_1 m_2 = (-\frac{1}{2})(4) = -2$. The final image is real ($s_2' > 0$), inverted ($m_T < 0$), and enlarged ($|m_T| > 1$).

42.2 The Eye

In the sections that follow, we will investigate the properties of some simple optical systems; the magnifying glass, the microscope, and the telescope. The purpose of all these devices is to make objects look bigger to the human eye. We have to begin our investigation with the function of the human eye. The eye behaves as a simple convex lens with a variable focal length. The magnifying power of the eye arises from two elements: the cornea and the crystalline lens. The focal length of the crystalline lens can be altered making the focal length of the system variable. The crystalline lens is not actually crystal, but layers of fiber. The eye focuses incoming light rays on the retina where they are converted to electrical signals that are transmitted to the brain by the optic nerve.

The Eye: The main parts of the human eye are drawn to the right. The focal length of the crystalline lens can be changed to change the focal length of the eye. The eye is mostly filled with clear liquid whose index of refraction is near that of water called the aqueous humor and vitreous humor.

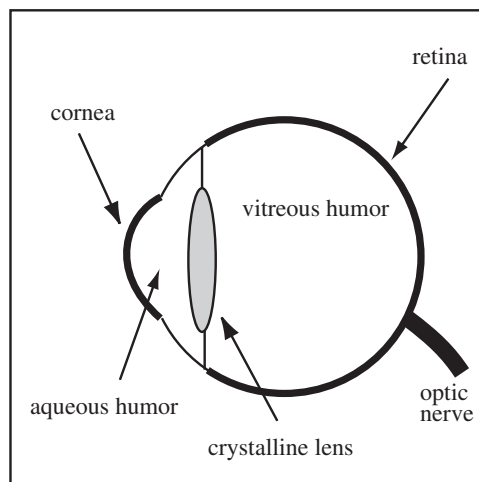

Focal Length of Eye: The human eye has an effective focal length of 1.7cm. This treats the combination of the cornea, crystalline lens, and humors as a simple thin lens in air. The actual size of the eye is 2.4cm and the final image is formed in the vitreous humor.

To change the focal length of the eye, muscles in the eye must exert a force on the crystalline lens. When these muscles are relaxed the eye is said to be relaxed. A well-functioning eye will focus incoming parallel rays on the retina when relaxed with focal length 1.7cm. Since many of you have glasses, not all eyes are well-functioning. The point where an object must be placed for the image to be focussed on the retina by a relaxed eye is called the *far point* of the eye. For a well-functioning eye, the far point is at infinity.

The Far Point: The far point of the human eye is the point that is in focus for a relaxed eye. For a normal eye, the far point is at infinity.

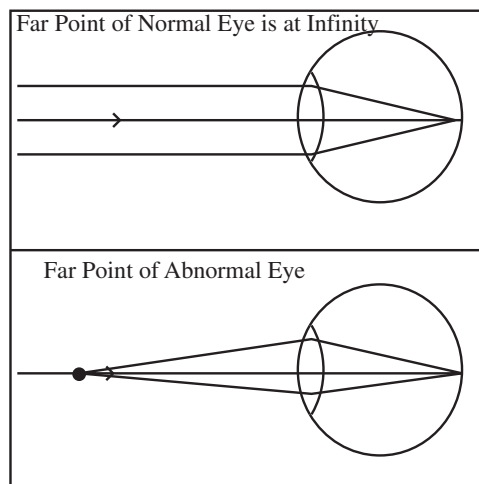

As an object is brought in from infinity the eye changes the focal length of the crystalline lens to keep the image of object focussed on the retina. This shift in focal length is called *accommodation*. As the object gets close to the eye, the eye can no longer change its focal length to focus the image on the retina. The closest point the eye can focus is called the *near point*.

The Near Point of the Eye: The near point of the human eye is the closest point where an object can be placed so that its image is focussed on the retina. The near point is about 7cm for a teenager, 12cm for a young adult, 28cm – 40cm in middle age, and 100cm at age 60. The near point of a normal eye is taken to be $\ell_{np} = 25\text{cm}$ for optical calculations.

A relaxed eye has focal length $f_r = 1.7\text{cm}$ which focusses parallel rays on the retina. The near point of a normal eye is about $\ell_{np} = 25\text{cm}$. An object placed at the near point is focussed on the retina by an eye at its minimum focal length. We can calculate the focal length of the normal eye at maximum accommodation using the thin lens equation,

$$\frac{1}{f_{np}} = \frac{1}{\ell_{np}} + \frac{1}{f_r} \Rightarrow \frac{1}{f_{np}} = \frac{1}{25\text{cm}} + \frac{1}{1.7\text{cm}}$$

Solving for the focal length, gives the focal length at maximum accommodation of $f_{np} = 1.59\text{cm}$.

We can understand common eye problems in terms of the near and far point of the eye.

Nearsightedness: An eye is nearsighted or myopic if parallel light rays are focussed to a point in front of the retina. Distant objects are blurry. For a nearsighted eye, the far point is not at infinity.

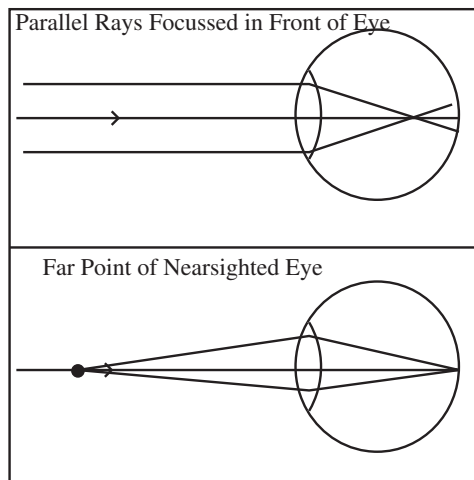

Farsightedness: Hyperopia or farsightedness happens when parallel rays are focussed beyond the retina. The eye must accommodate to bring far objects into focus. There is a limit to the amount of accommodation so the near point of the eye is much larger than the normal near point of 25cm. Therefore, objects near the eye are blurry.

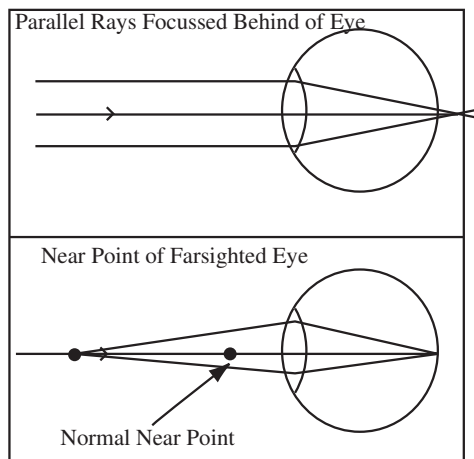

The magnification m we have been calculating is of limited use when evaluating the function of optical instruments. For example, no matter how you cut it, the image of a star formed in a telescope is smaller than the star itself.

Angular Magnification or Magnifying Power (MP): The magnifying power, MP , or angular magnification of an optical system is the ratio of the angle formed by the image on the retina using the optical system, α_s , to the angle formed without the optical system at the eyes normal viewing distance, α_u . The normal viewing distance is usually taken as the near point.

$$MP = \frac{\alpha_s}{\alpha_u}$$

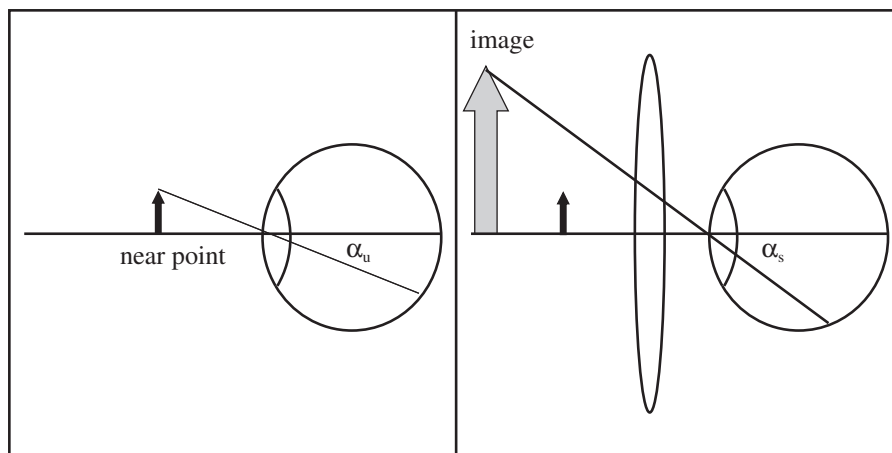

42.3 A Simple Magnifier

Our first optical system is the simple magnifier or more commonly the magnifying glass. This is a single lens that is used to make small objects appear bigger to the human eye.

Example 42.3 Magnifying Power of a Magnifying Glass

Problem: My daughter's magnifying glass has a focal length of 30cm. An object is 10cm from the lens. I hold the lens so the length from the lens to my eye is the focal length. Calculate the magnifying power of the lens and the magnification of the lens.

Solution

(a) Draw the System: The important distances are the distance of the eye to the near point l_{np} , the distance of the lens to the eye $l_e = f$, and the distance of the image to the eye l_i .

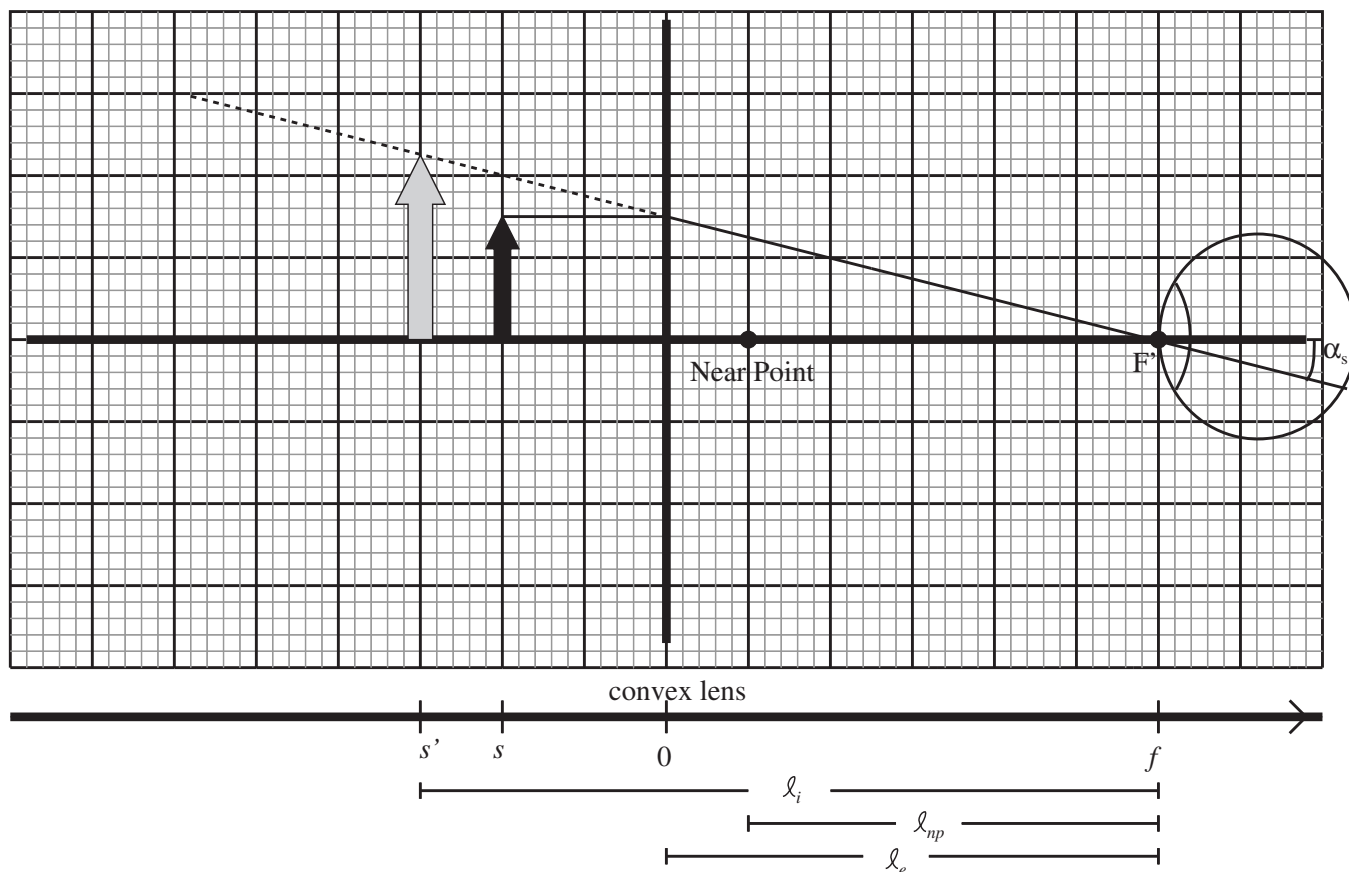

(b) Solve for the image location: The location of the image can be found by the thin lens equation as usual

$$\frac{1}{f} = \frac{1}{s} + \frac{1}{s'} \quad \Rightarrow \quad \frac{1}{30\text{cm}} = \frac{1}{10\text{cm}} + \frac{1}{s'}$$

Solving for the image distance yields, $s' = -15\text{cm}$ and a magnification of $m = -s'/s = -(-15\text{cm})/(10\text{cm}) = \frac{3}{2}$.

(c) Solve for the Magnifying Power: The magnifying power MP of the lens is the ratio of the angle α_s the image using the optical system makes on the retina to the angle α_u on the retina with only the unaided eye. The angle α_u is calculated with the object at the near point, the closest it can be brought and still be in focus, $\alpha_u = h_0/\ell_{np}$ where h_0 is the height of the object and I continue to use the small angle approximation to turn $\tan \alpha$ into α . With the lens, the angle on the retina is $\alpha_s = h_i/\ell_i$ where ℓ_i is the distance of the image to the eye and h_i is image height. The magnifying power is defined as

$$MP = \frac{\alpha_s}{\alpha_u} = \frac{h_i \ell_{np}}{h_o \ell_i}$$

The ratio of the image height to the object height is the magnification $m = h_i/h_o = \frac{3}{2}$. The distance of the image to the eye is, observing the diagram, $\ell_i = \ell_e - s' = 30\text{cm} - (-15\text{cm}) = 45\text{cm}$. I will use the standard value of $\ell_{np} = 25\text{cm}$ for my near point, so the magnifying power of the lens for this ℓ_e and s is

$$MP = \frac{h_i \ell_{np}}{h_o \ell_i} = \frac{3}{2} \frac{25\text{cm}}{45\text{cm}} = 0.833$$

For this choice, the object actually appears smaller than it would if observed without the glass at the near point. In what follows, we investigate this system in general to find magnifying powers greater than 1. Note the difference between the magnification and the magnifying power.

If we use the distances set up in the example, ℓ_{np} the near point distance, ℓ_i the distance of the image to the eye, and ℓ_e the distance of the lens to the eye we can develop a general expression for magnifying power

and investigate some useful case. As in the example, the magnifying power is

$$MP = \frac{\alpha_s}{\alpha_u} = \frac{h_i \ell_{np}}{h_o \ell_i}$$

and the magnification is defined as

$$m = -\frac{s'}{s} = \frac{h_i}{h_o}$$

so the magnifying power can be written

$$MP = -\frac{s' \ell_{np}}{s \ell_i}$$

If we re-arrange the lens equation,

$$\frac{1}{f} = \frac{1}{s} + \frac{1}{s'} \quad \Rightarrow \quad \frac{s'}{s} = \frac{s'}{f} - 1$$

so the magnifying power can be written,

$$MP = \left(1 - \frac{s'}{f}\right) \frac{\ell_{np}}{\ell_i}$$

The image distance is related to the distance of the image to the eye by $s' = \ell_e - \ell_i$, since the image distance is negative.

$$MP = \left(1 + \frac{\ell_i - \ell_e}{f}\right) \frac{\ell_{np}}{\ell_i}$$

Magnifying Power of a Magnifying Glass: The magnifying power of a single lens of focal length f is

$$MP = \left(1 + \frac{\ell_i - \ell_e}{f}\right) \frac{\ell_{np}}{\ell_i}$$

where ℓ_i is the distance from the image to the eye, ℓ_e is the distance from the lens to the eye, and ℓ_{np} is the distance from the eye to the near point.

So let's play with this expression a little and investigate some importance cases:

- **Case I:** $\ell_e = 0$: Suppose we're holding the glass very close to the eye so that $\ell_e = 0$. In this case the magnifying power becomes

$$MP = \left(1 + \frac{\ell_i - \ell_e}{f}\right) \frac{\ell_{np}}{\ell_i} = \left(\frac{1}{\ell_i} + \frac{1}{f}\right) \ell_{np}$$

In this case, the magnifying power increases as the distance of the image to the eye decreases. The closest the image can be brought to the eye and still be in focus is the near point, so the maximum magnifying power in this case is

$$MP_{max, \ell_e=0} = \left(\frac{1}{\ell_{np}} + \frac{1}{f}\right) \ell_{np} = 1 + \frac{\ell_{np}}{f}$$

For my daughter's lens used in the example, the maximum magnifying power in this case is

$$MP_{max, \ell_e=0} = 1 + \frac{\ell_{np}}{f} = 1 + \frac{25\text{cm}}{30\text{cm}} = 1.833$$

- **Case II:** $\ell_e = f$: I can also hold the lens so the eye is at its focal point. In this case,

$$MP_{\ell_e=f} = \left(1 + \frac{\ell_i - \ell_e}{f}\right) \frac{\ell_{np}}{\ell_i} = \left(1 + \frac{\ell_i - f}{f}\right) \frac{\ell_{np}}{\ell_i} = \frac{\ell_{np}}{f}$$

This was the case used in the example, because it was easy to draw, and we reproduce the magnifying power found in the example $MP = 25\text{cm}/30\text{cm} = 0.833$.

- **Case III:** $l_i = \infty$ If we place the object a focal length's distance from the lens, the image forms at negative ∞ and the magnifying power is

$$MP = \left(1 + \frac{l_i - l_e}{f}\right) \frac{l_{np}}{l_i} = \left(\frac{1}{l_i} + \frac{l_i - l_e}{fl_i}\right) l_{np} = \left(\frac{1}{\infty} + \frac{\infty - l_e}{f\infty}\right) l_{np} = \frac{l_{np}}{f}$$

So for my daughter's lens, $MP_{l_i=\infty} = 0.833$ It is this case, that is used to determine the power of a lens.

Power of a Lens: The power of a lens is the magnifying power when $l_i = \infty$, $MP = \frac{l_{np}}{f}$, and is reported as MPx . If a lens has a magnifying power $MP = 2$ when the image is at infinity, then the lens is a $2x$ lens.

My daughter's lens is rated at $2x$ so those dirt bags used a child's near point to rate the lens.

42.4 The Compound Microscope

With an understanding of a simple magnifier, we can understand another common optical system, the compound microscope. A compound microscope improves the performance of a simple magnifier by adding a second lens, called an *objective*. The objective forms a real enlarged image of the object somewhere in the microscope tube. A simple magnifier, called the *eyepiece*, is placed so that the image of the objective is at the focal point of eyepiece (Case III above) to further magnify the image. The important features of a microscope are drawn below. The large squares are 2cm wide.

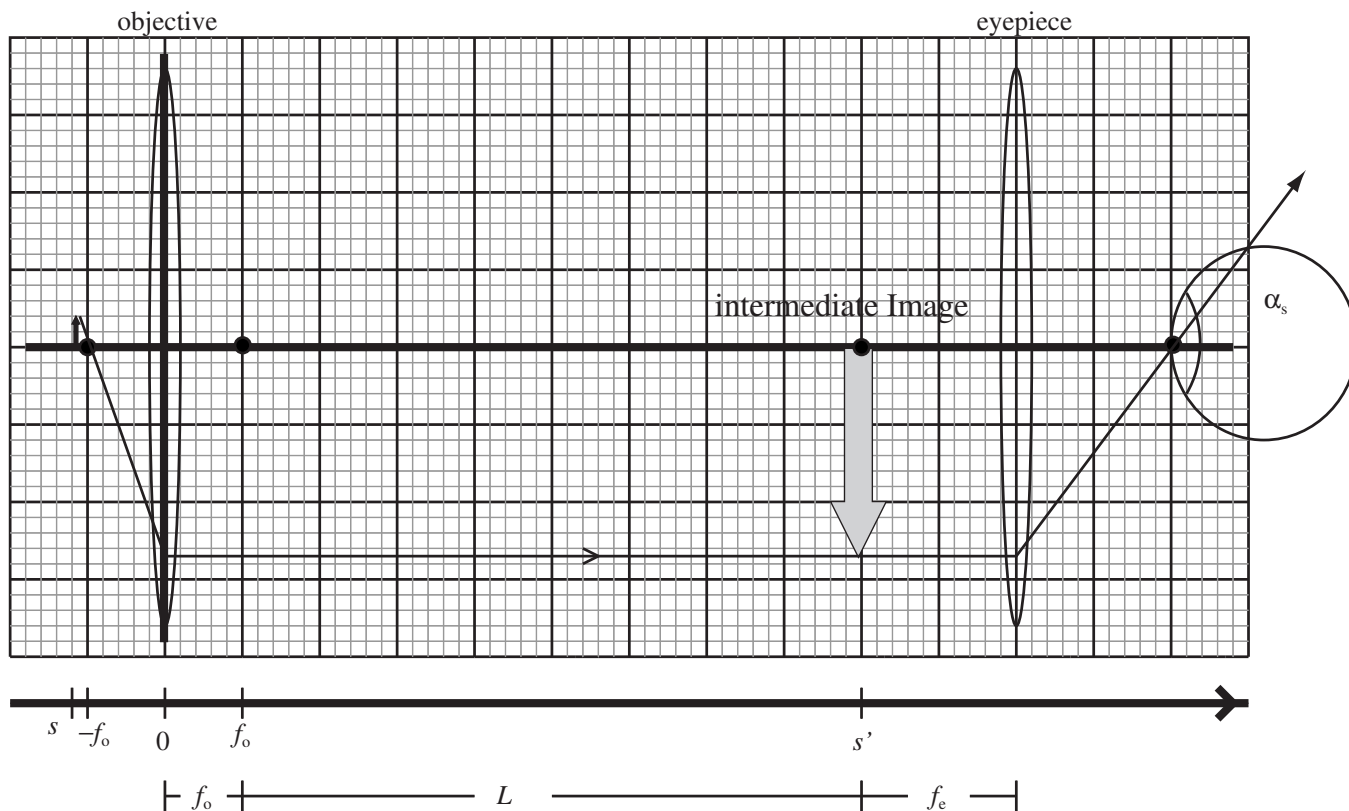

The distance L between the focal points of the objective and eyepiece is called the *tube length*. Normally, the tube length is chose to be $L = 16\text{cm}$ as used in the figure. The microscope drawn uses an objective with focal length $f_o = 2\text{cm}$ and an eyepiece with focal length $f_e = 4\text{cm}$. We already know how to calculate the magnifying power of an eyepiece, a simple magnifier, where the object is at the focal point leaving the image at infinity, $MP_{eyepiece} = l_{np}/f_e = 25\text{cm}/4\text{cm} = 6.25$. Therefore the eyepiece is a $6x$ eyepiece. The function

of the objective is to make the object larger. The magnification of the objective is $m = -s'/s$. The image distance is $f_o + L$, so using the thin lens equation

$$\frac{1}{s} + \frac{1}{s'} = \frac{1}{f_o} \quad \Rightarrow \quad \frac{s'}{s} + 1 = \frac{s'}{f_o}$$

$$m = -\frac{s'}{s} = 1 - \frac{s'}{f_o} = 1 - \frac{f_o + L}{f_o} = -\frac{L}{f_o}$$

The total magnifying power of the microscope is the product of the magnification of the objective and the magnifying power of the eyepiece,

$$MP = m \cdot MP_{\text{eyepiece}} = \left(-\frac{L}{f_o}\right) \left(\frac{\ell_{np}}{f_e}\right)$$

Magnifying Power of Microscope: The magnifying power of a compound microscope is given by

$$MP = \left(-\frac{L}{f_o}\right) \left(\frac{\ell_{np}}{f_e}\right) = MP_{\text{objective}} \cdot MP_{\text{eyepiece}}$$

where L is the tube length, the distance between the two focal points, f_o is the focal length of the objective, and f_e is the focal length of the eyepiece.

Magnifying Power of the Objective: The magnifying power of a microscope objective is

$$MP_{\text{objective}} = \left(-\frac{L}{f_o}\right)$$

If $L = 16\text{cm}$ and $f_o = 1.6\text{cm}$, then $MP = 10$ and the objective is a $10x$ objective.

For the microscope drawn in above the magnifying power of the objective is $MP_{\text{objective}} = -16\text{cm}/2\text{cm} = -8$ so the objective is an $8x$ objective. The total magnifying power of the microscope $MP = MP_{\text{objective}}MP_{\text{eyepiece}} = (-8)(6.25) = -50$ or $50x$.

Example 42.4 Reverse Engineering a Microscope

Problem: Let's do a little reverse engineering off the internet. A student microscope is advertised with a $10x$ objective and a $4x$ eyepiece. Find the focal lengths of the eyepiece and the objective, the distance between the lenses, the total power, and the object location.

Solution

(a) Compute the Focal Length of the Objective: The magnifying power of the objective is $MP_{\text{objective}} = 10 = \left|\frac{L}{f_o}\right|$ so the focal length of the objective is $f_o = L/10 = 1.6\text{cm}$.

(b) Compute the Focal Length of the Eyepiece : The magnifying power of the eyepiece is $MP_{\text{eyepiece}} = 4 = \left|\frac{\ell_{np}}{f_e}\right|$ so the focal length of the eyepiece is $f_e = \ell_{np}/4 = 6.25\text{cm}$.

(c) Compute the Distance Between the Lenses: Reviewing the diagram at the beginning of the section, the distance between the lenses is $f_o + L + f_e = 1.6\text{cm} + 16\text{cm} + 6.25\text{cm} = 23.85\text{cm}$

(d) Compute the Total Power: The total power of the microscope is the product of the magnifying power of the objective and the magnifying power of the eyepiece, $MP = 10 \times 4 = 40$.

(e) Compute the Object Location: The object must be placed to produce an image at $s' = L + f_o$. Using the thin lens equation,

$$\frac{1}{s} + \frac{1}{s'} = \frac{1}{f_o} \quad \Rightarrow \quad \frac{1}{s} + \frac{1}{L + f_o} = \frac{1}{f_o} \quad \Rightarrow \quad \frac{1}{s} + \frac{1}{17.6\text{cm}} = \frac{1}{1.6\text{cm}}$$

So the object distance, $s = 1.76\text{cm}$.

42.5 The Telescope

Telescopes are used to make distant objects appear larger to the human eye. Some telescopes use lenses for the objective and are called *refracting telescopes*. Some telescopes use a concave mirror for the objective and are called *reflecting telescopes*. It is easier to make and support big mirrors than it is to make big lenses, so large telescopes are reflecting while small telescopes are generally refracting. Both types of telescopes are arranged so the secondary focal point of the objective falls at the same place as the primary focal point of the eyepiece. Since telescopes are used to view distant objects, the incoming rays are nearly parallel. A simple refracting telescope is drawn below.

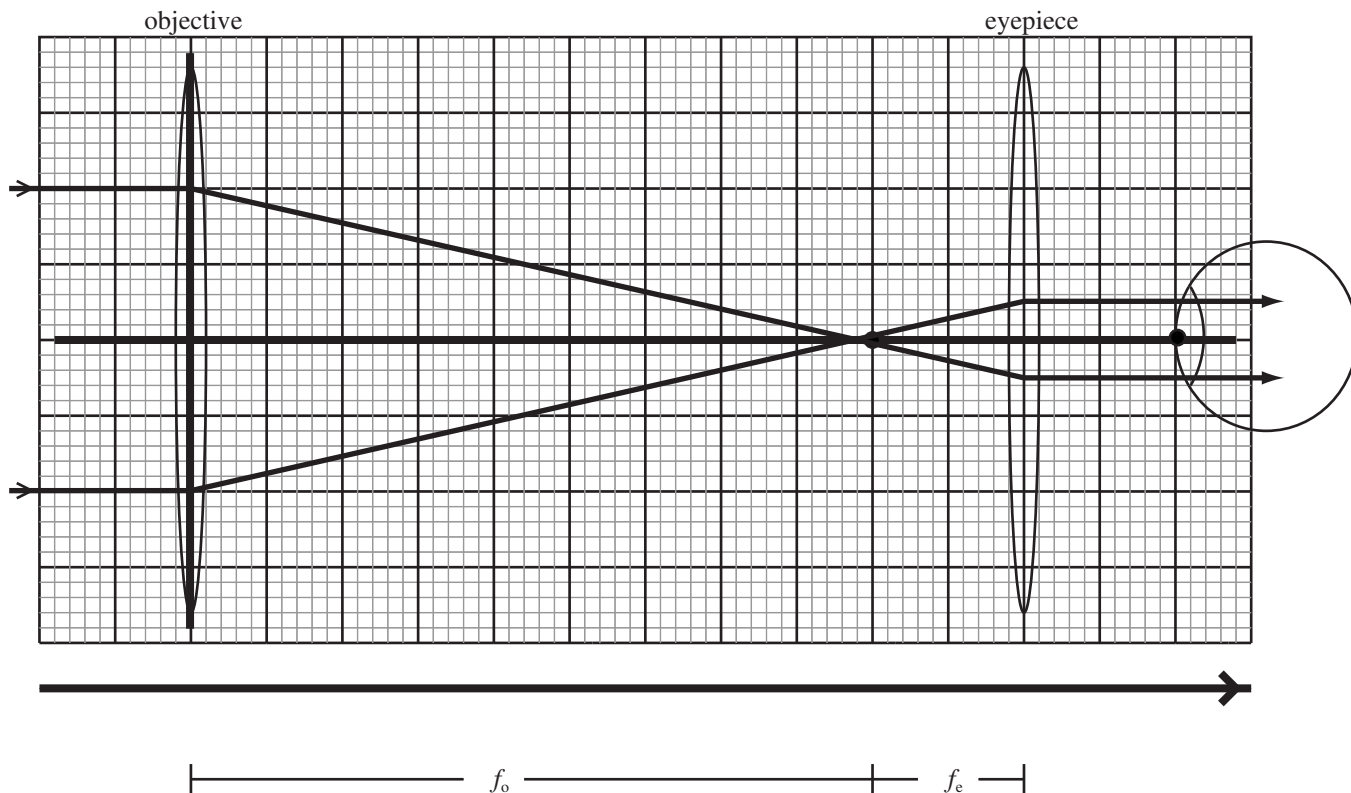

Unfortunately this diagram is completely useless, because it appears since the telescope moves parallel rays together, that it makes objects smaller. A telescope views an angle α_u of a distant object. Since the length of the telescope is negligible when compared to the object distance, α_u is the angle the image of the object makes on the retina without the telescope. Trace this ray through the telescope.

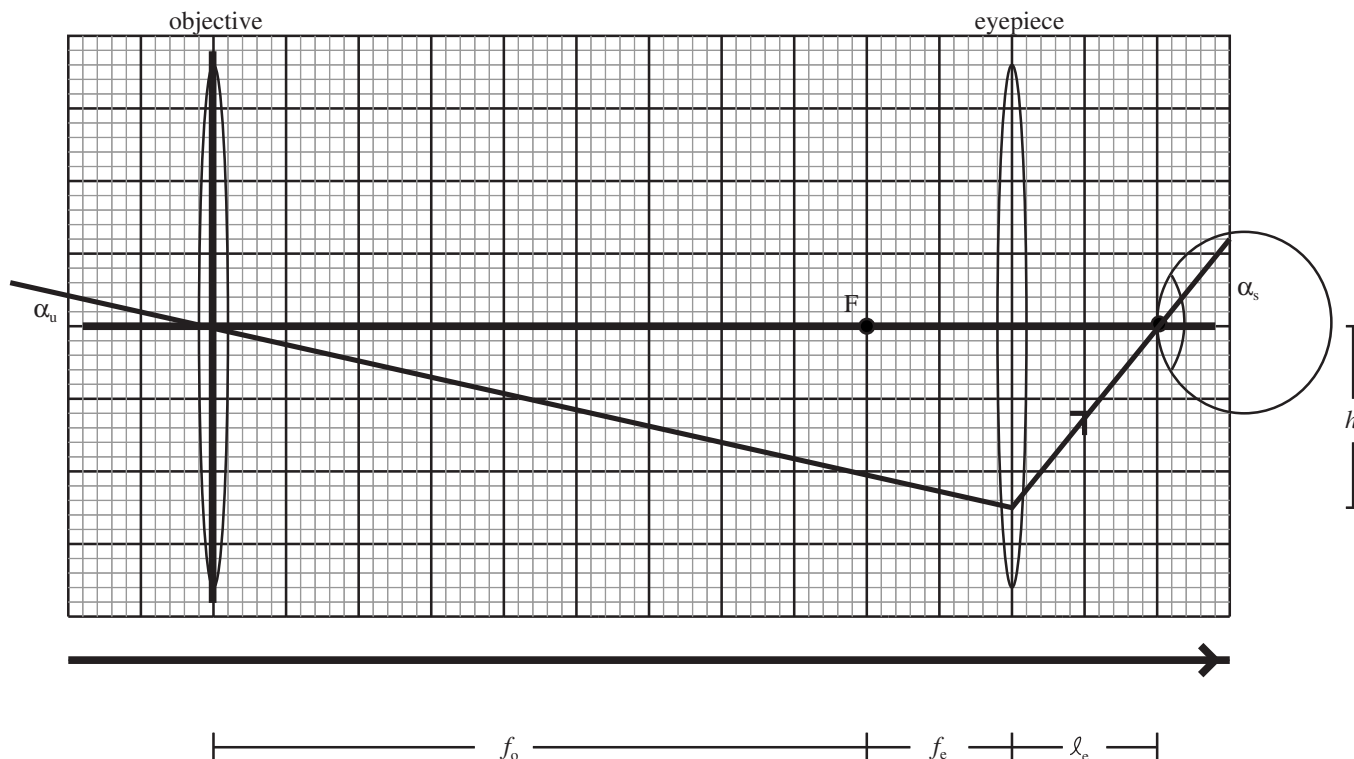

The magnifying power is the ratio $MP = -\alpha_s/\alpha_u$. The negative sign is needed because the image is inverted. If the ray hits the eyepiece a distance h from the axis and ℓ_e is the distance from the eyepiece to the eye, then using the small angle approximation, $\alpha_u = h/(f_o + f_e)$ and $\alpha_s = h/\ell_e$. The magnifying power is then

$$MP = -\frac{\alpha_s}{\alpha_u} = -\frac{h/\ell_e}{h/(f_o + f_e)} = -\frac{f_o + f_e}{\ell_e}$$

We can find ℓ_e by noting that since the ray passes through the center of the objective, it behaves as if it came from a point object at the objective, so we can use the thin lens equation to determine where it again intersects the axis at the eye. The object distance is the distance between the lenses, $s = f_o + f_e$, and the image distance is $s' = \ell_i$,

$$\frac{1}{s} + \frac{1}{s'} = \frac{1}{f_e} \quad \Rightarrow \quad \frac{1}{f_o + f_e} + \frac{1}{\ell_i} = \frac{1}{f_e}$$

Therefore,

$$\frac{1}{\ell_i} = \frac{1}{f_e} - \frac{1}{f_o + f_e} = \frac{f_o}{f_e(f_o + f_e)}$$

and the magnifying power

$$MP = -\frac{f_o + f_e}{\ell_e} = -(f_o + f_e) \frac{f_o}{f_e(f_o + f_e)} = -\frac{f_o}{f_e}$$

Magnifying Power of the Telescope: The magnifying power of a telescope is

$$MP = -\frac{f_o}{f_e}$$

A refracting telescope works the same way, with the focal point of the eyepiece placed at the same point as the focal point of the mirror. We have an additional problem, we have to get the light out of the telescope somehow. Most refracting telescopes you see in stores use a plane mirror to bend the rays from the objective out the side of the tube to the eyepiece.

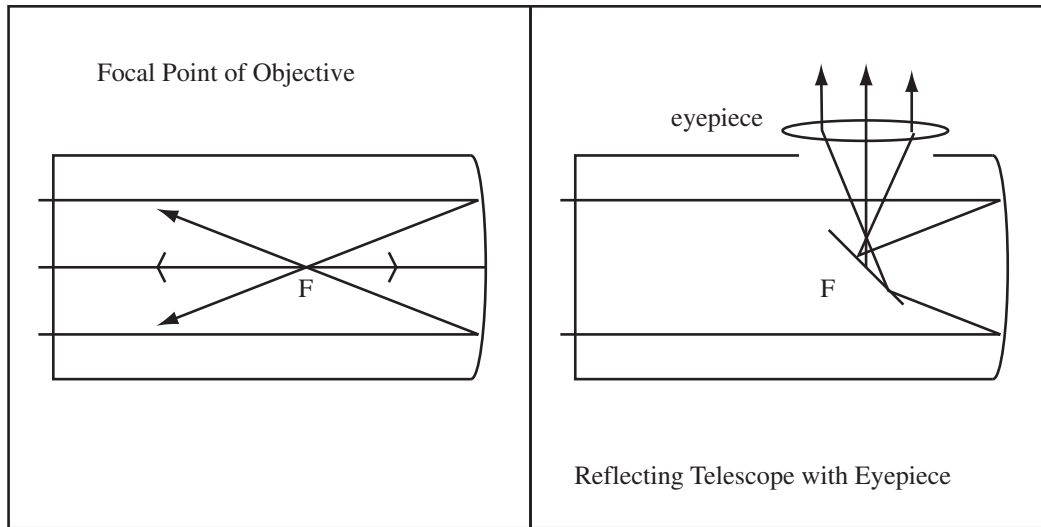

Example 42.5 Magnifying Power of a Telescope

Problem: My daughter Kat bought a telescope from Wal-mart with the money she earned grading lecture quizzes. The telescope is the fifty dollar reflecting scope. It has an objective with focal length $f_o = 70\text{cm}$ and an eyepiece with focal length 2.5cm . Calculate the power of the telescope.

Solution

The magnifying power is $-f_o/f_e = -70\text{cm}/2.5\text{cm} = -28$ or $28x$.

Chapter 43

Appendix

43.1 Units

A list of unit conversions follows:

Newton(N): The Newton is the unit for force,

$$1\text{N} = 1 \frac{\text{kgm}}{\text{s}^2}$$

Joule(J): The joule is unit for energy,

$$1\text{J} = 1 \frac{\text{kgm}^2}{\text{s}^2} = 1\text{Nm}$$

Ampere(A): The Ampere is the unit used to measure current

$$1\text{A} = 1 \frac{\text{C}}{\text{s}}$$

Volt(V): The volt is the unit of potential difference and *emf*,

$$1\text{V} = 1 \frac{\text{Nm}}{\text{C}}$$

Ohms (Ω): The unit for resistance is the Ohm,

$$1\Omega = 1 \frac{\text{V}}{\text{A}} = 1 \frac{\text{Nms}}{\text{C}^2} = 1 \frac{\text{Js}}{\text{C}^2}$$

Tesla(T): A tesla is the unit used for a magnetic field,

$$1\text{T} = 1 \frac{\text{Ns}}{\text{Cm}} = 1 \frac{\text{N}}{\text{Am}}$$

A related unit is the Gauss, $1\text{T} = 1 \times 10^4\text{G}$.

Weber(Wb): The Weber is the unit for magnetic flux

$$1\text{Wb} = 1\text{Tm}^2$$

Henry(H): The Henry is the unit for inductance,

$$1\text{H} = 1 \frac{\text{Wb}}{\text{A}} = 1 \frac{\text{Tm}^2}{\text{A}}$$

43.2 Constants

The Speed of Light(c) $c = 3 \times 10^8 \frac{\text{m}}{\text{s}}$

Permittivity of Free Space(ϵ_0) $\epsilon_0 = 8.85 \times 10^{-12} \frac{\text{C}^2}{\text{Nm}^2}$.

Permeability of Free Space(μ_0) $\mu_0 = 4\pi \times 10^{-7} \frac{\text{Tm}}{\text{A}}$.

k $k = 1/4\pi\epsilon_0 = 8.99 \times 10^9 \frac{\text{Nm}^2}{\text{C}^2}$.

Quantum of Charge (e) $e = 1.602 \times 10^{-19}\text{C}$.

Charge of Proton $q_p = +e = 1.602 \times 10^{-19}\text{C}$.

Charge of Electron $q_e = -e = -1.602 \times 10^{-19}\text{C}$.

Mass of Electron $m_e = 9.11 \times 10^{-31}\text{kg}$.

Mass of Proton $m_p = 1.67 \times 10^{-27}\text{kg}$

Acceleration of Gravity(g) $g = 9.81 \frac{\text{m}}{\text{s}^2}$.

43.3 Presenting your Work

We will work with you to improve the quality of the presentation of your written work. This is partially selfish because we have to read your work and you wouldn't believe some of the stuff that gets dumped on us. Mostly, however, it is to help you become a better student. When you write a solution to a physics problem, you are explaining your reasoning to yourself. When your description is incomplete, your explanation to yourself is incomplete, and probably your understanding is incomplete. Very messy work hides errors. At minimum, on a test, we require a good solution for full credit. A good solution includes:

- Diagram if Requested
- Symbolic Formulas
- Calculation with symbols not numbers
- Substitution with units
- Answer with units and vectors (if appropriate)
- Vital Reasoning in English

Example 43.1 Example of a Good Solution

Problem: One point charge with charge 3nC exerts a force of 100N on another point charge with charge 5nC . Compute separation of the charges.

Solution

$$F = \frac{kq_1q_2}{d^2} \quad \text{Formula}$$

$$d = \sqrt{\frac{kq_1q_2}{F}} \quad \text{Symbolic solution}$$

$$d = \sqrt{\frac{(8.99 \times 10^9 \frac{\text{Nm}^2}{\text{C}^2})(3\text{nC})(5\text{nC})}{(100\text{N})}} \quad \text{Substitution with units}$$

$$d = 2.12 \times 10^{-5}\text{m} \quad \text{An answer with units}$$

Note, since this is a simple application of a formula no English description is required for a good solution and no diagram was requested.

The above is pretty minimal. If any steps were left out of the above example, it would be an example of a poor solution and might not score all the points it deserved on a homework or a test. A great solution will also have

- A diagram, even if the problem doesn't specifically ask for one.
- Explanation of what is being done in words. In this case, Use Coulomb's for the electric force and solve for the separation, d .
- Guiding English, section headings, formula names, etc. In this case the phrase Apply Coulomb's Law. Solve for separation.
- Vital reasoning explained in complete sentences. None was needed in the example.

Example 43.2 Example of a Great Solution

Problem: One point charge with charge 3nC exerts a force of 100N on another point charge with charge 5nC . Compute separation of the charges.

Solution

Strategy: Use Coulomb's law and then solve for the separation.

(a) Use Coulomb's Law for the electric force,: Since both charges are positive the force is repulsive.

$$F = \frac{kq_1q_2}{d^2}$$

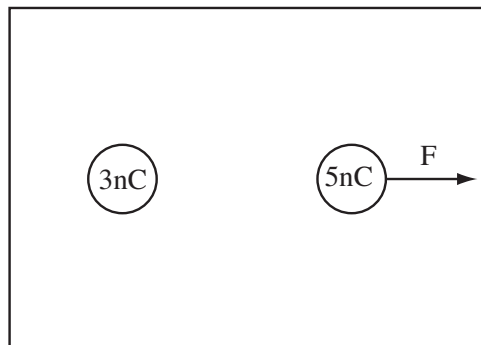

(b) Solve for Separation:

$$d = \sqrt{\frac{kq_1q_2}{F}}$$

$$d = \sqrt{\frac{(8.99 \times 10^9 \frac{\text{Nm}^2}{\text{C}^2})(3\text{nC})(5\text{nC})}{(100\text{N})}}$$

$$d = 2.12 \times 10^{-5}\text{m}$$

Note, a reader can tell what is going on from the English, they don't have to guess from the math.

Chapter 44

Index

The index is on the next page. I'm still playing with this part of text.