

Electricity and Magnetism - Test 3 - Spring 2014

Work four of the six problems. Place the problems in the order you wish them graded. The first two problems form the first half test; the second two problems form the second half test.

Problem 3.1 A cylindrical region $s < a$ is co-axial with the z axis. The magnetic field in the region is given by

$$\vec{B} = B_0 \frac{s}{a} \hat{z}$$

Compute the vector potential both inside and outside the cylinder.

Problem 3.2 To correctly store bar magnets, two bar magnets should be connected with ferromagnetic bars as shown below. Let the magnetization of the magnetic material be M_0 . Let the height of the magnets be h and the center to center length of the iron bars (keepers) be ℓ . Compute the magnetic field in the iron and the magnetization density of the iron. What would the magnetic field be if one of the magnets were reversed. (My TAs would routinely store the good magnet sets with the dipoles parallel).

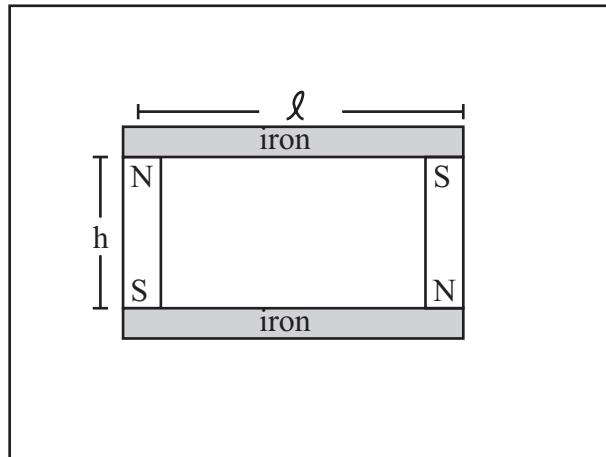

Problem 3.3 A hollow conducting copper pipe with inner radius a and outer radius b co-axial with the z axis has relative permeability μ_r . A constant current flows in the space $s < a$ inside the pipe $\vec{J} = -J_i \hat{z}$. The system also carries a current that varies with position $\vec{J} = J_c \frac{a}{s} \hat{z}$ in the copper ($a < s < b$). No current flows in the region $s > b$. Compute \vec{H} , \vec{B} , and \vec{M} everywhere. J_c and J_i are constants.

Problem 3.4 A metal washer is touched to a magnet and a uniform magnetization density $\vec{M} = M_0 \hat{z}$ is established. A washer is a short metal cylinder co-axial with the z axis of height h , inner radius a and outer radius b . Approximate the washer as infinitely short. Compute the magnetic field at the origin.

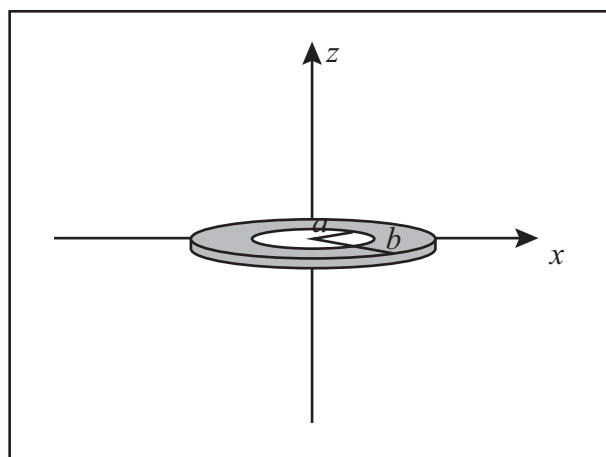

Problem 3.5 A solenoid is wound with N turns over a distance ℓ . The solenoid is co-axial with the z axis and is wound so if observed from the positive z direction it carries a current I counterclockwise. The solenoid may be approximated with the infinite solenoid field. A small magnet circular with magnetization density $M_0\hat{x}$ is inside the solenoid. The magnet is centered at the origin, has height h and radius R . The flat surface of the magnet makes a right angle with the x axis as drawn. Compute the torque exerted on the magnet.

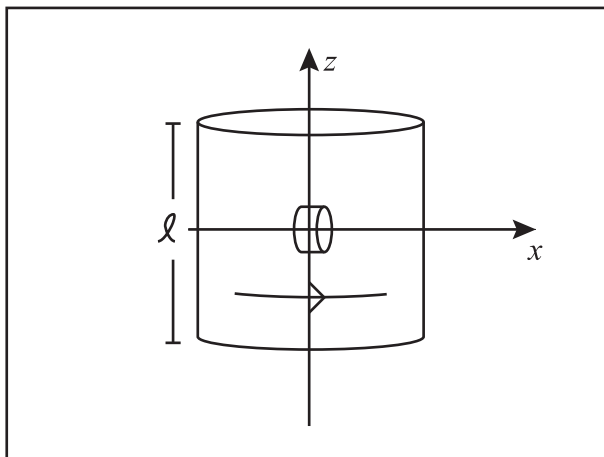

Problem 3.6 A finite cylindrical magnet is co-axial with the z axis. The magnet occupies the volume $-\ell < z < \ell$ and $a < s < b$ and contains magnetization density $\vec{M} = M_0 s \hat{s}$. Compute all bound surface and volume currents. Carefully report on what part of the surface the bound current flows. Note, the direction of the magnetization is in the \hat{s} direction. Compute the magnetic field due to the top surface current at the center of the top face of the magnet, at $\vec{r} = (0, 0, \ell)$.

