

Nathanael Franks

Dr. John Stewart

UPII Honors Project

27 April 2011

Marx Generator

Introduction: For those who itch to witness high voltage sparks, the Marx generator may be of interest. First described by Erwin Otto Marx in 1924, it is essentially an electric circuit designed to increase the input voltage by charging capacitors in parallel and discharging them in series via spark gaps. Thus in theory, the input voltage, V , is multiplied by the number of capacitors, n , to obtain an output voltage, nV (Plasmana 2011). In practice, this is far from the case due to practical constraints and inefficiencies. The Marx generator shares many similarities with lightning and thus is used by many museums and aviation companies as a simulator. High amounts of ultraviolet radiation, and occasionally X-rays, are released during the formation of the sparks.

Materials:

- Circuit board platform (3x9inches)
- Ten 1nF, 6Kv ceramic capacitors
- Twenty 1 Mohm, 2 Watt carbon film resistors
- Two 4.7 Mohm, 1 Watt metal glaze resistors
- 4 Kv Power supply
- Electrical tape or nail polish to improve efficiency.

Procedure:

- Stick the leads of two 1 Mohm resistors and one capacitor through circuit board as shown in the bottom view. The capacitor should be centered in between the two resistors.

- Tightly wrap the leads of the resistors around those of the capacitor and cut off excess. Do NOT cut the leads of the capacitor, which will be used for the spark gaps in future steps.
- Solder them together without any sharp points, which will cause corona discharge and decrease performance.
- Repeat until all twenty 1 Mohm resistors and ten capacitors are connected as shown in the bottom view.
- Solder the 4.7Mohm resistors in a similar fashion, leaving one lead from each as a connection to the input power supply.
- Bend the leads of the capacitor into the shape of a “V”. Each “V” should be roughly 2mm apart, forming the spark gaps upon discharge of the capacitors. The pointy ends of the leads should not be too close to others, which will cause large amounts of corona discharge.
- Wire the freshly built Marx generator to the high voltage power supply and flip the switch. After this point, drain the capacitors before touching the device again or there may not be a second time. This can be a lethal device.
- A fair amount of fine tuning of the spark gaps may be needed to produce large sparks. Electrical tape or nail polish may be applied to reduce corona discharge in undesirable areas.
 - If a faint hissing or snap noise is produced, one or more of the spark gaps may be too far from or too close to each other. Adjust the distance. Continuous arcing may happen between the spark gaps, especially near the supply end. The distance simply needs fine tuning.

- If the generator is working but produces a large “pop” and then ceases to work again, it is very likely that a capacitor has been destroyed from excess voltage. In this case, replace the capacitor and reduce the input voltage. Possibly, but less likely, the high voltage power supply may have been fried by the voltage spikes from the generator.

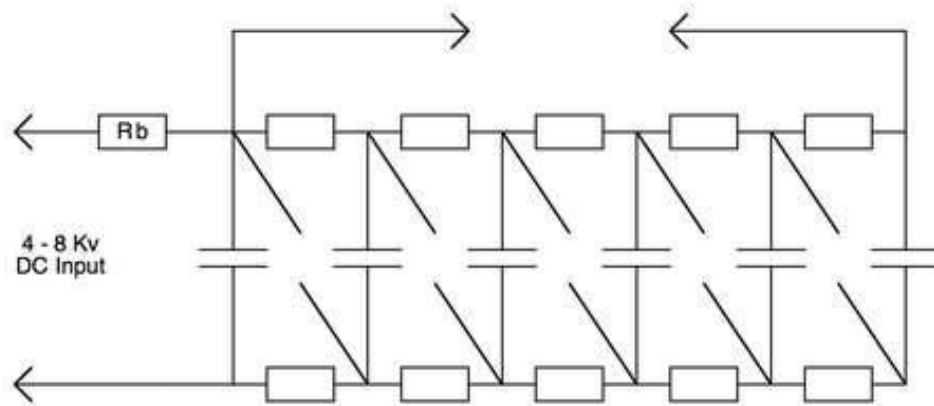
Schematic (from *Instructables*)

Top View

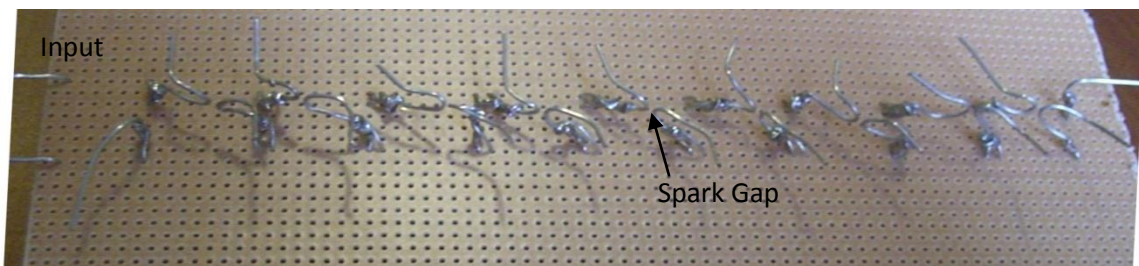

Bottom View

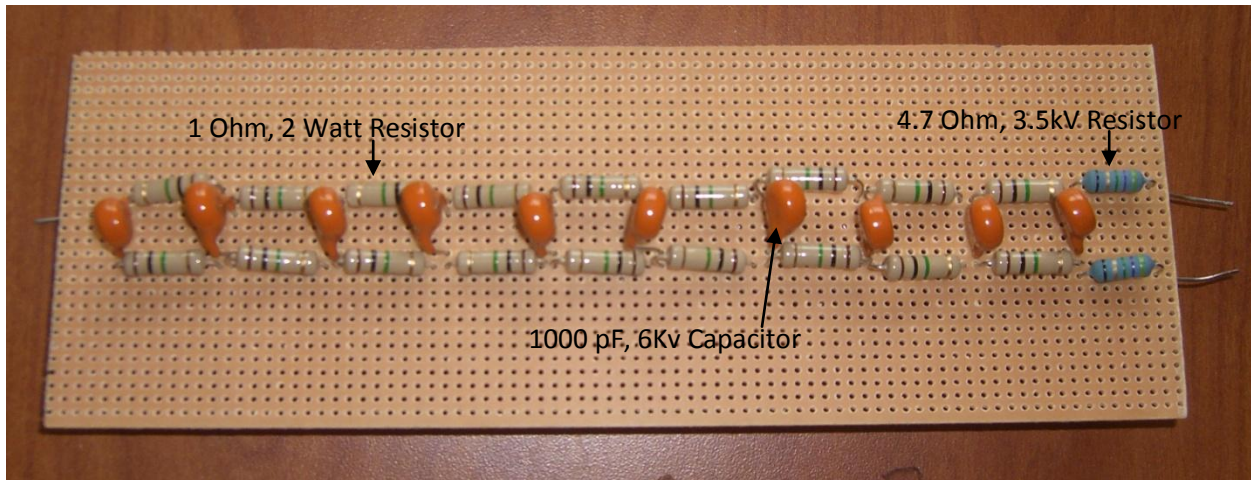

Discussion: The Marx generator functioned fantastically, creating bright, loud sparks consistently around 1 inch in length, which is the potential of around 40 Kv (Plasmana 2011). A few were seen at around 1.5 inches, but only rarely. The increase in voltage due to the capacitors at the output can be compared to that at the input by holding the ground wire near the device at specific points. Near the input, no spark will form, while near the middle of the device after a few capacitors have increased the voltage, a $\frac{1}{4}$ inch spark can be seen. Thus the potential increases as one nears the end of the capacitor array. A large amount of spark gap fine tuning was required to obtain consistent results. If one of the gaps is too distant, the device fails to work. If one is too close, continuous arcing between the gaps reduces the performance.

Bibliography

El-Sharkawi, Mohamed. *Electric Energy: An Introduction*. CRC Press: New York, 2005.

Irene, Eugene. *Electronic Materials Science*. Wiley-Interscience: New Jersey, 2005.

Kularatna, Nihal. *Power Electronics Design Handbook: Low-power Components and Applications*. Newnes: Boston, 1998.

Plasmana. "Build a simple Marx Generator". *Instructables*: 2011.

<<http://www.instructables.com/id/Build-a-simple-Marx-Generator/>>

Steiner, John. *Illustrated Guide to Basic Electronics: With Useful Projects and Experiments*. Prentice Hall: New Jersey, 1984.

Gibilisco, Stan. *Electricity Demystified*. McGraw-Hill: San Francisco, 2005.