

### Mechanics Fall 2009 - Test 3

Work four of the five problems. Place the problems in the order you wish them graded. The first two problems form the first half test; the second two problems form the second half test.

**Problem 3.1** A hockey puck (a uniform cylinder of radius  $a$  and mass  $m$ ) moves across a frictionless two-dimensional surface after being struck. Calculate Hamilton's equations of motion. Report the generalized momenta. Solve the equations of motion for the initial conditions  $x(0) = 0, y(0) = 0, \theta(0) = 0, \dot{x}(0) = v, \dot{y}(0) = 0, \dot{\theta}(0) = \omega$ .

**Problem 3.2** A block of mass  $M$  is connected to two springs of spring constant  $k$  and slides in one dimension on a frictionless surface. Another block of mass  $m = M/2$  is free to move on top of the first block. The contact between the first and second block is also frictionless. The mass  $m$  is connected to the block of mass  $M$  by two springs of spring constant  $k$  and also moves in one dimension. Find the normal mode frequencies of the system. Note, this is obviously a coupled system, if you make a mistake and decouple it, it will displease me.

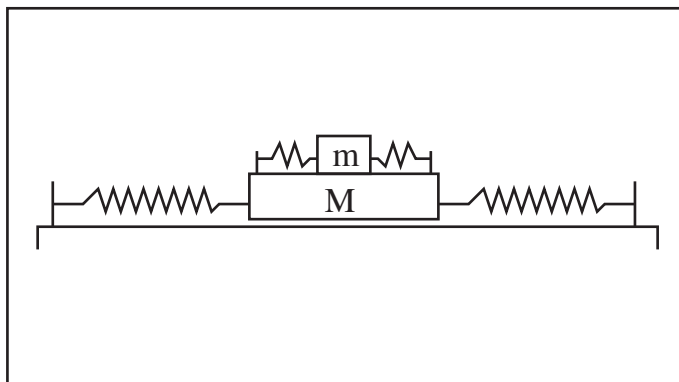

**Problem 3.3** Consider the potential function

$$V(x) = \gamma x e^{-ax^2}$$

where  $\gamma$  and  $a$  are positive constants. Does this potential have points of stable equilibrium? If yes, find the point or points and prove they are stable. Find the minimum energy of the system and the frequency of small oscillations about equilibrium. If there are no points of stable equilibrium, compute the force on the particle and calculate the trajectory of the particle if released from the origin.

**Problem 3.4** A mass  $m$  slides in a linear frictionless tube attached to a disk with moment of inertial  $I = \frac{1}{2}MR^2$  that is pivoted to rotate about its center in the horizontal plane. A linear spring with spring constant  $k$  is attached to the disk as drawn. The system is in equilibrium in the orientation drawn and the spring is connected with a string such that the connection point is always as drawn in the figure. Find the equations of motion for the system.

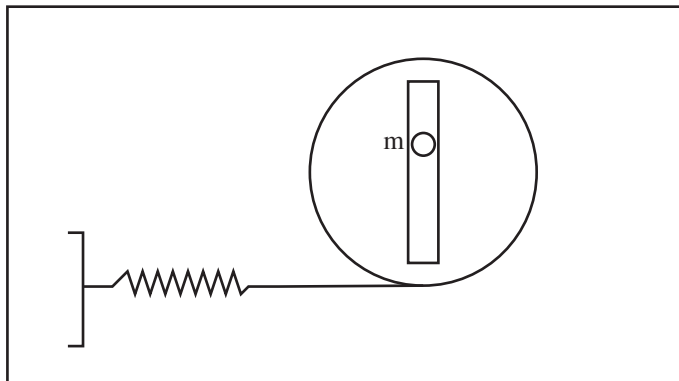

**Problem 3.5** A mass  $m$  slides in a frictionless tube. The tube is rotated with constant angular velocity  $\omega$  about its center in the horizontal plane. The mass experiences a linear restoring force  $-kr$  toward the center of the system. Under what conditions does the particle oscillate about the center of the tube? What is the frequency of these oscillations? Under conditions where the particle does not oscillate, qualitatively describe its motion.